

Chassis and Body

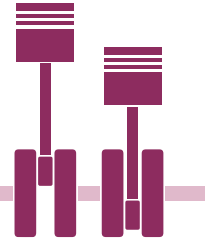

Contents

9.0 Introduction	9.4.1 Functions of the Vehicle Body
9.1 Chassis Frame	9.4.2 Requirements of the Vehicle Body
9.1.1 Functions of the Chassis Frame	9.4.3 Types of Vehicle Body
9.1.2 Types of Chassis Frame	9.4.3.1 Goods Vehicle Body
9.1.2.1 Conventional Frame	9.4.3.2 Passenger Vehicle Body
9.1.2.2 Semi Integral Frame	
9.1.2.3 Integral Frame	
9.1.3 Various Loads Acting on the Frame	
9.2 Chassis	9.5 Tinkering And Painting
9.2.1 Construction of the Chassis	9.5.1 Tinkering
9.2.2 Parts Mounted on the Chassis Frame	9.5.2 Tools Used for Tinkering
9.2.3 Materials Used for the Chassis Frame	9.5.3 Painting
9.3 Important Dimensions of the Vehicle	9.5.4 Precautions to be Followed During Tinkering and Painting
9.4 Body	



Learning objectives

1. To make the student to understand about the need, purpose and types of Chassis frame, sub systems of chassis mounted on the chassis.
2. To make the student to understand on vehicle body, classification of vehicles.



9.0 Introduction

The various parts of the vehicle are mounted on the chassis frame. The chassis frame must be strong enough to withstand the total weight of the vehicle. The chassis frame carries the engine, clutch, gear box, Propeller shaft, rear axle, suspension, steering gear box and brake. The frame is fixed with two longitudinal bars and four or five cross bars by rivet or bolts.



9.1 Chassis frame

- The skeleton of the vehicle is the chassis frame.
- Chassis frames are made up of alloy steel and it is of high strength to make the rigid structure.
- Based on the construction, application, load capacity of the vehicle, the chassis frame is made up of different sizes and shapes.
- The chassis frame forms the backbone of the vehicle.

9.1.1 Functions of the chassis frame

1. To withstand the weight of the vehicle, passenger and goods.
2. To form the base to mount the engine, suspension, steering and power transmission system.
3. To build the vehicle body on the chassis frame.
4. To withstand the reaction due to driving and braking force.
5. To absorb the ground reaction forces due to road undulations.
6. To withstand the static load and dynamic load of a vehicle.

9.1.2 Types of chassis frame

Chassis frames are broadly classified into three types, namely:

1. Conventional Frame
2. Semi Integral Frame
3. Integral or Unit Frame

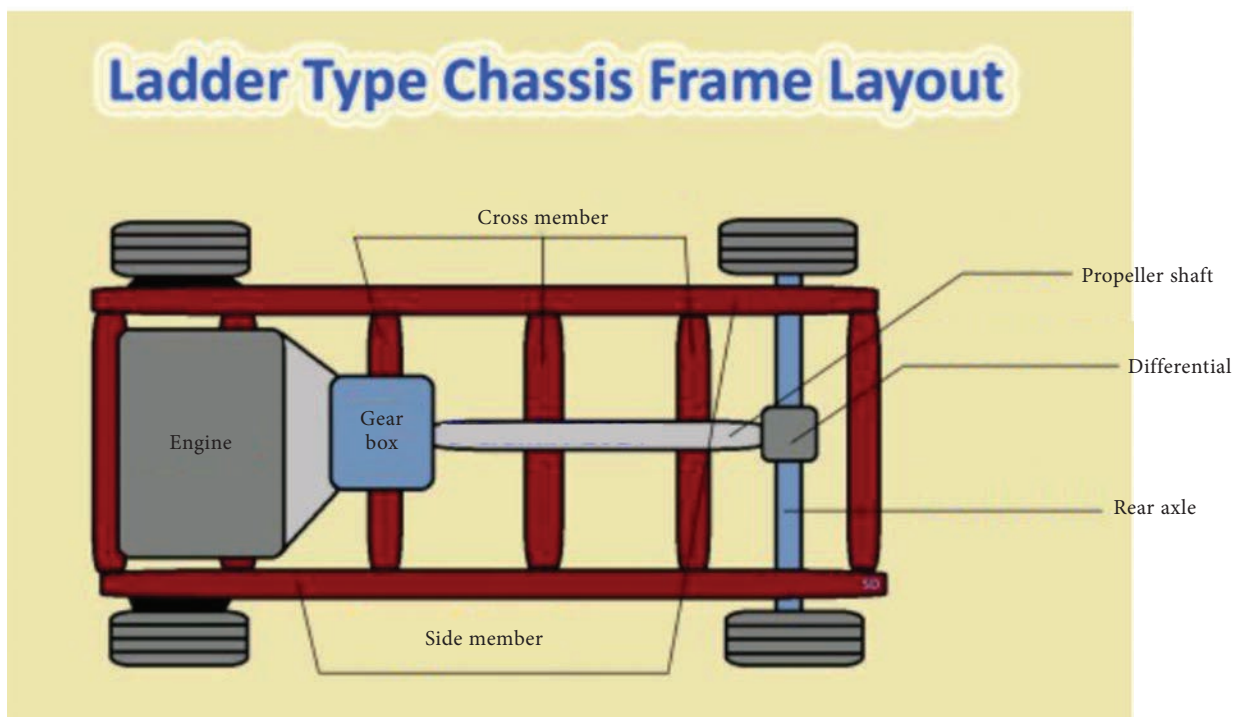
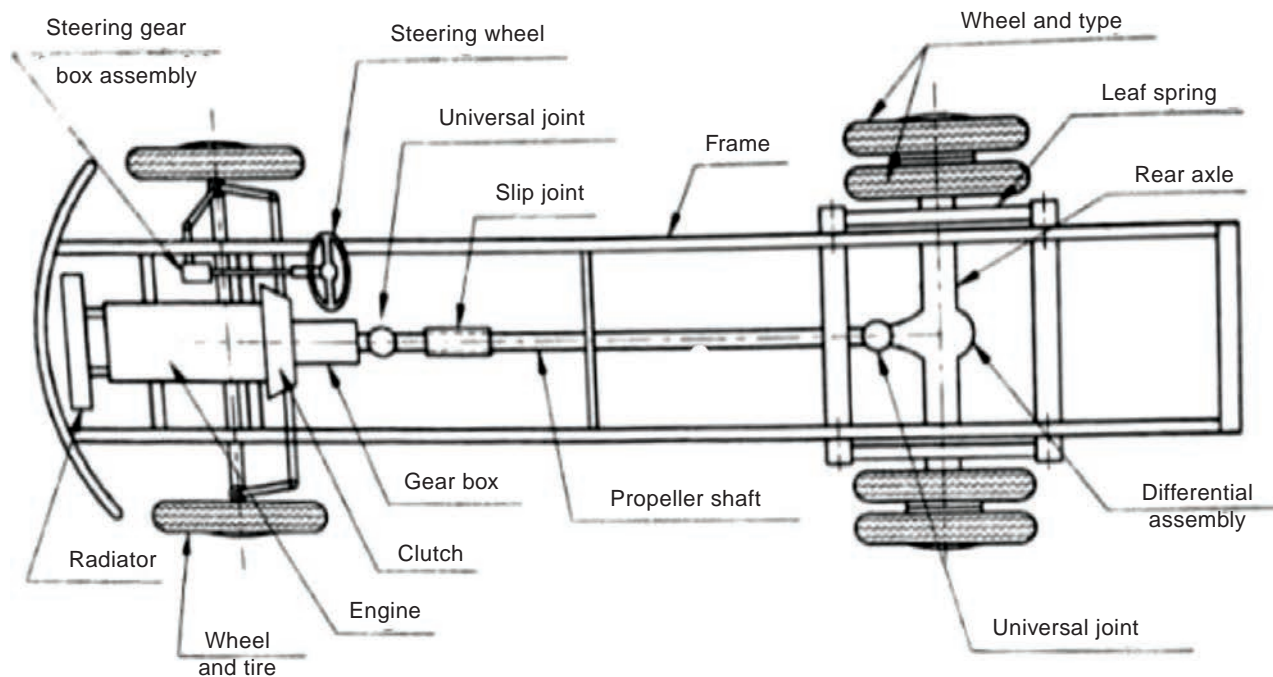
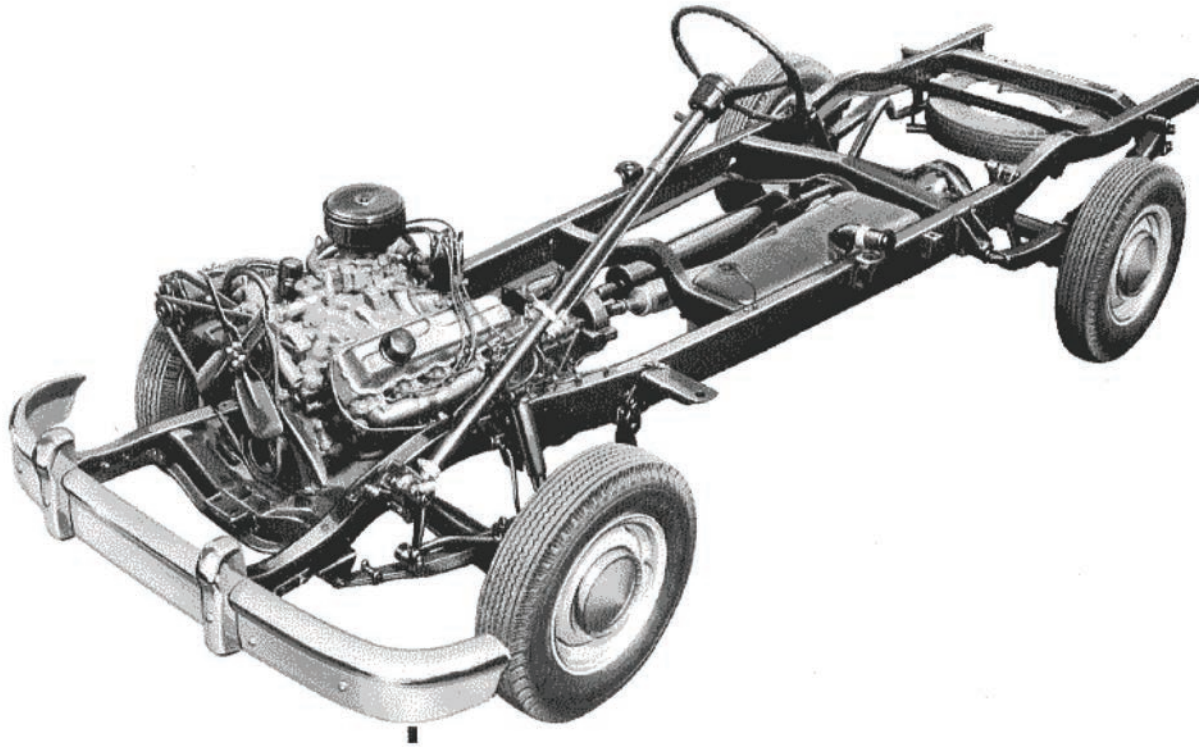

Figure 9.1 Ladder type chassis frame

9.1.2.1 Conventional Frame

Here the various components are attached to frame and the vehicle body are superimposed on it. The total frame is mounted on the wheel axle by means

of springs. This arrangement makes the body completely isolated from the frame deflection. It is mostly used in heavy vehicles like buses, trucks etc.



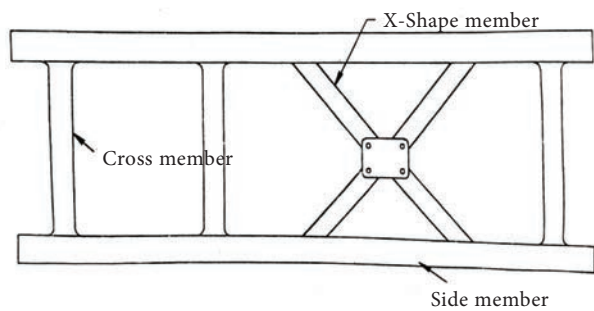

Figure 9.1.2.1 Conventional frame

9.1.2.2 Semi Integral Frame

This type of frames is made up of two or three sections and then it is integrated. The particular portion of the frame can be replaced if any damaged happens during accident instead of replacing the entire frame.



Figure 9.1.2.2 Semi integral frame

9.1.2.3 Integral Frame

In this type of construction, there is no separate frame. All the assembly units are attached to the body. Heavy side members of the frames are eliminated and cross members are combined with the floor of the body. The body of the vehicle gives a mounting for engine, transmission, suspension and other mechanical units. Weight of the vehicle is very much reduced and widely used in cars.



Figure 9.1.2.3 (a) Integral frame

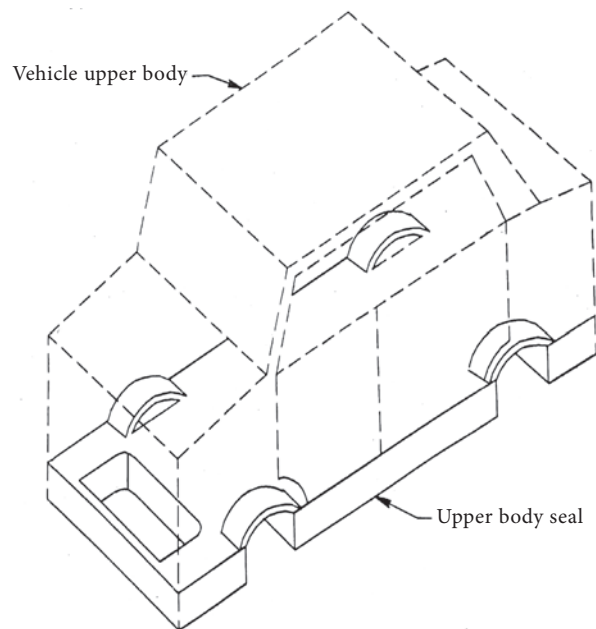

Figure 9.1.2.3 (b) Integral frame



Figure 9.1.2.3 (c) Integral frame

9.1.3 Various loads acting on the frame

1. Vertical loads when the vehicle comes across a bump or pit and road undulation
2. Engine torque and braking torque
3. Loads due to road camber, side wind, cornering force, Centrifugal force while taking a turn.
4. Aerodynamic forces at considerable speed
5. Weight of different components like engine, transmission, passengers, fuel

tank, seats, exhaust acting at mounting points

6. Sudden impact loads during a collision



9.2 Chassis

In an automobile, all the subsystems excluding the body is called as Chassis.

9.2.1 Construction of the chassis

The layout of various subsystems is shown in the figure.

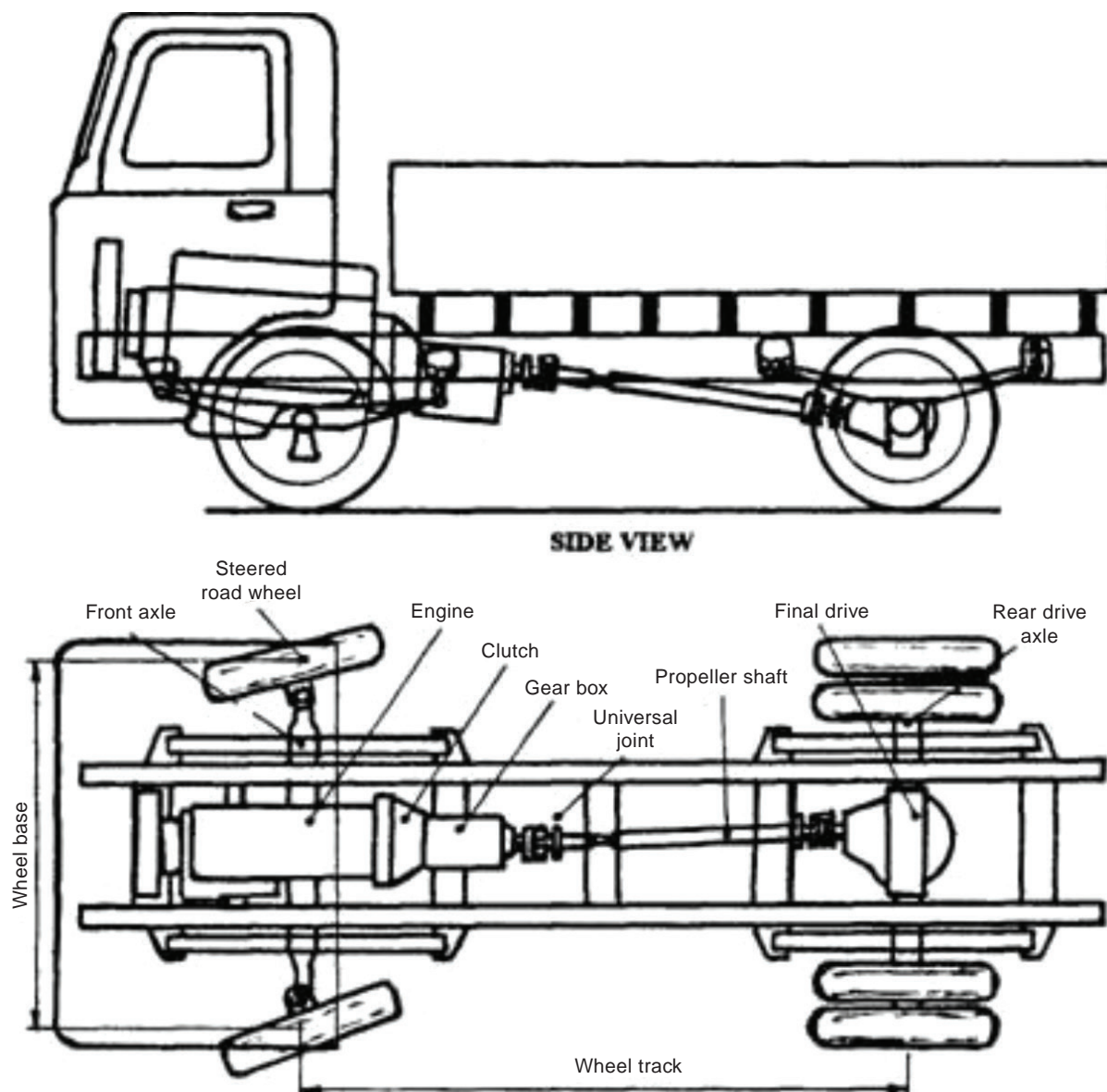

Figure 9.2.1 (a) Construction of the Chassis

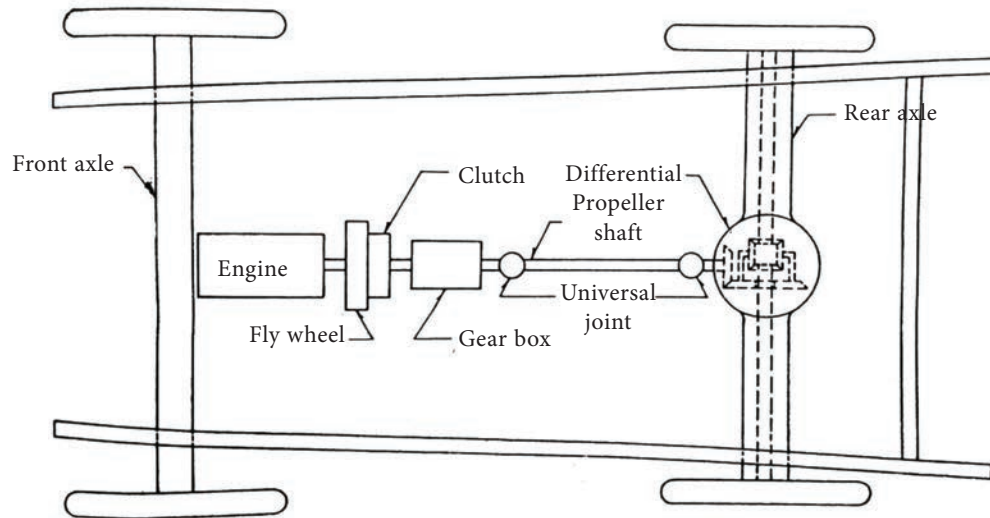
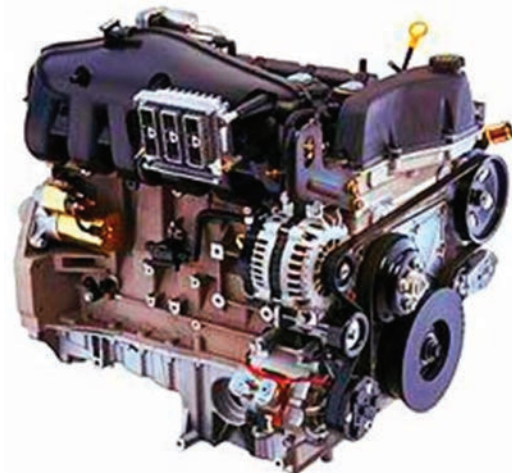

Figure 9.2.1 (b) Construction of the Chassis

In the present manufacturing of the vehicle, the body is separately fabricated and it is mounted over the chassis. The important subsystems that are connected in the chassis frame includes engine, clutch assembly, gear box, suspension system, wheels and tires, steering system, brake, fuel tank, electrical system etc.



9.2.2 Parts mounted on the chassis frame

1. Chassis frame

Chassis frame is fixed with two longitudinal bars and four or five cross bars by rivet or bolts. Quality alloy steel is used to withstand the total weight of the vehicle. It is considered as the backbone of the vehicle.

2. Engine

The driving power of the vehicle is provided by the engine. It converts the chemical energy in the fuel into mechanical energy to propel the vehicle. The engine power is transmits to road wheel through clutch, gear box and rear axle.

3. Clutch

The main function of the clutch is to take up the drive smoothly from the engine and to release or disengage whenever desired. It is fixed in between engine and gear box. To avoid broken of gears in the gear box.



4. Gearbox

According to operating conditions, to provide the necessary torque variation from the engine to the drive wheels, gear box is used. Also, to reverse the direction of the vehicle whenever required.

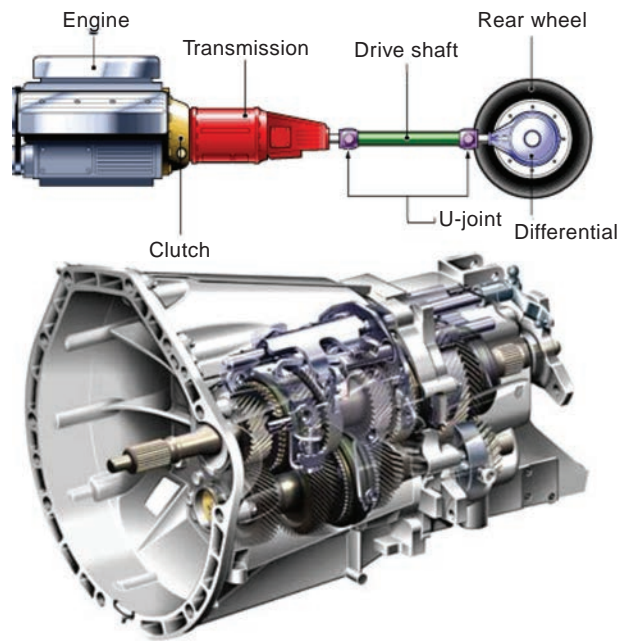

5. Suspension system

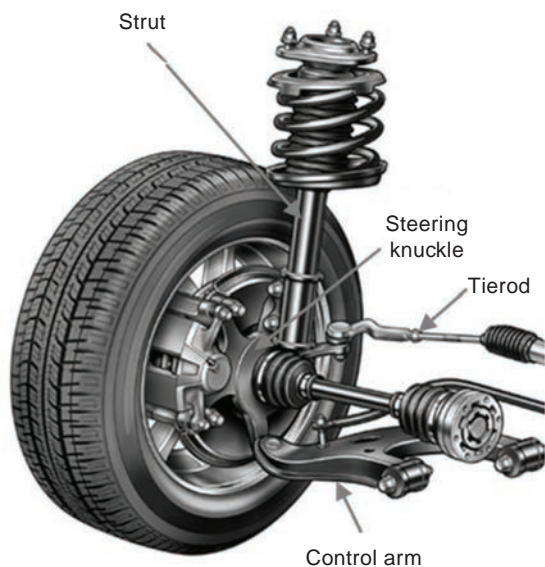

Suspension system is used to prevent the road shock and to enhance ride comfort to the passenger and to the various vehicle components. They also preserve vehicle stability under various

road conditions. It is fixed in between axle and chassis frame.

6. Brake system

Brake systems are used to stop the vehicle, or to reduce the vehicle speed, and to prevent rolling of the vehicle when travelling on inclined surface. Brakes are fixed in each four wheels. Its functions by using mechanical linkage, hydraulic power and air.



7. Steering system

Steering system is used to change the direction of the vehicle as desired by the driver. The steering systems helps in reducing the drivers work through mechanical advantage, to control the vehicle according to road condition and speed.



8. Electrical system

Electrical system includes ignition system lighting system, starting system,

charging system and other electrical accessories. Electrical energy for all the system is provided by the battery. Battery is known as heart of the electrical system.

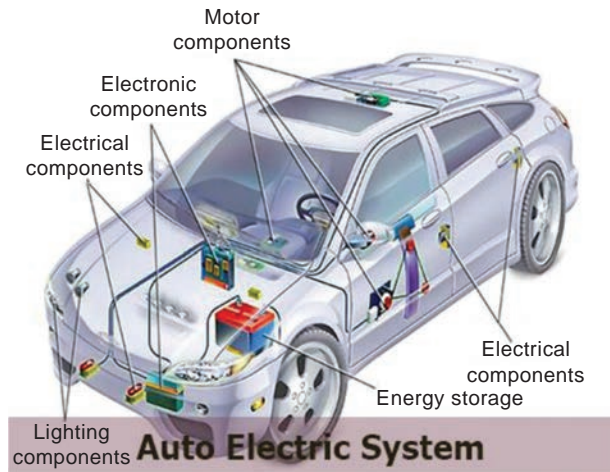

9.2.3 Materials Used for the Chassis Frame

Frame should be extremely rigid and strong so that it can withstand shocks, twist, stresses and vibrations when vehicle is moving on road. The chassis frame should be made from high strength materials. The following materials are widely used for the manufacture of the chassis frame.

1. Mild sheet Steel
2. Carbon sheet Steel
3. Sheet Nickel Alloy

The chemical composition of nickel alloy steel is

- Carbon – 0.25% - 0.35%
- Manganese – 0.35% - 0.75%
- Silicon – 0.30%
- Nickel – 3%
- Phosphorus – 0.05%
- Sulphur – 0.5%



9.3 Important dimensions of the vehicle

1. Wheel base

- Wheel base is the distance between the centres of the front and rear wheels.

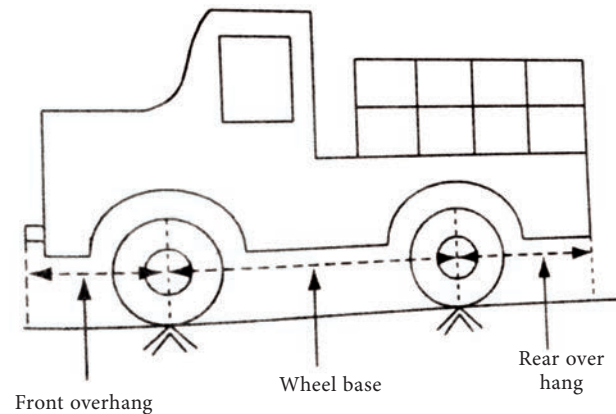

Figure 9.3.1 Wheel base

2. Wheel track

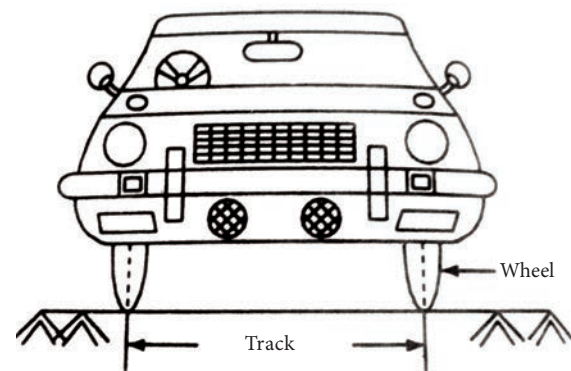
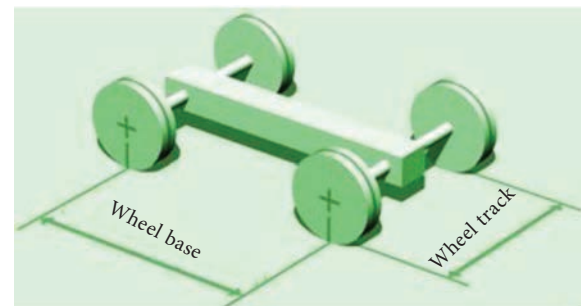

Figure 9.3.2 Wheel track

- Wheel track is the distance between both the front wheels or rear wheels measured from the centres of tyres.

3. Front over hang

Front over hang is the distance between the front bumper and centre of front axle.

4. Rear over hang

Rear over hang is the distance between the rear bumper and centre of rear axle.

5. Over all width

The distance between the two side members is called over all width.

6. Over all height

It is the amount of space between the ground surface to the upper side of the vehicle body is called over all height.

7. Over all length

The distance between the centre of front and rear bumper is called as over all length.

8. Ground Clearance

- Ground clearance is the amount of minimum space between the road surface and the underside of the chassis.

9.4 Body

Body is the superstructure for all vehicles. It may either constructed separately and bolted to the chassis or manufactured integral with the chassis.

- The chassis and body make the complete vehicle.
- A body consists of windows and doors, roof, luggage compartment, passenger seats etc.
- A body should be designed such that it will against the air resistance, gradient resistance and rolling resistance.

9.4.1 Functions of the vehicle body

1. Vehicle body protects the passengers and the goods from sunlight.
2. Prevent the dust from entering into the vehicle.
3. Protects the passenger from rainfall.

9.4.2 Requirements of the vehicle body

1. Weight of the body should be as minimum as possible.
2. It should have minimum number of components.
3. It should have reasonable fatigue life.

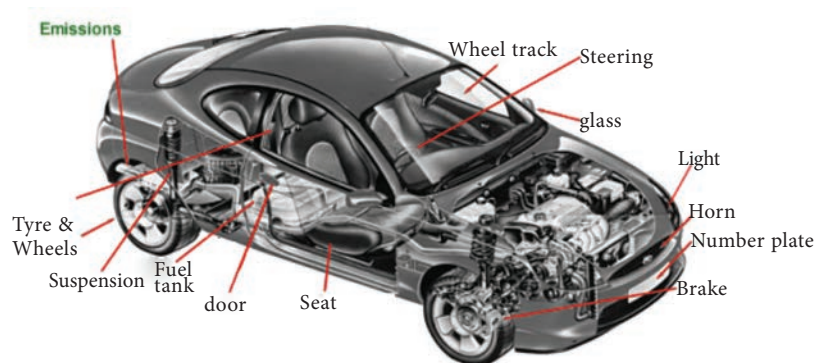

Figure 9.4 Body

4. It must provide adequate space for both the passenger and the luggage.
5. It should create minimum vibration during running.
6. Weight and stresses induced in the body should be distributed evenly to all portions.
7. It should be able to cope with impact loads of reasonable magnitude and safe guard the passengers during accidents.
8. The shape of the body should be such that the air resistance is minimum
9. It is easy to manufacture as well as cheap in cost.
10. It should be easy to maintenance.

9.4.3 Types of vehicle body

Vehicle bodies are classified into two types namely

1. Goods vehicle body
2. Passenger vehicle body.

9.4.3.1 Goods vehicle body

This type of vehicle bodies is used for transportation of goods. Based on the nature of the goods transported, Engine horsepower, load carrying capacity, the vehicle bodies are designed.

9.4.3.2 Passenger vehicle body

This type of vehicle bodies is used for transportation of passengers. Based on the number of passengers, level of luxury, engine horsepower, the vehicle body is designed.

The various types of vehicle bodies are shown in 9.4.3 table.

Passenger Transport

- a. Small car bodies up to six seat capacity.
- b. Medium car bodies up to ten seat capacities.
- c. Mini bus Bodies.
- d. Large bus body for common and Luxurious transport.
- e. Railway coach bodies.
- f. Three Wheeled Bodies

Vehicle body classifications

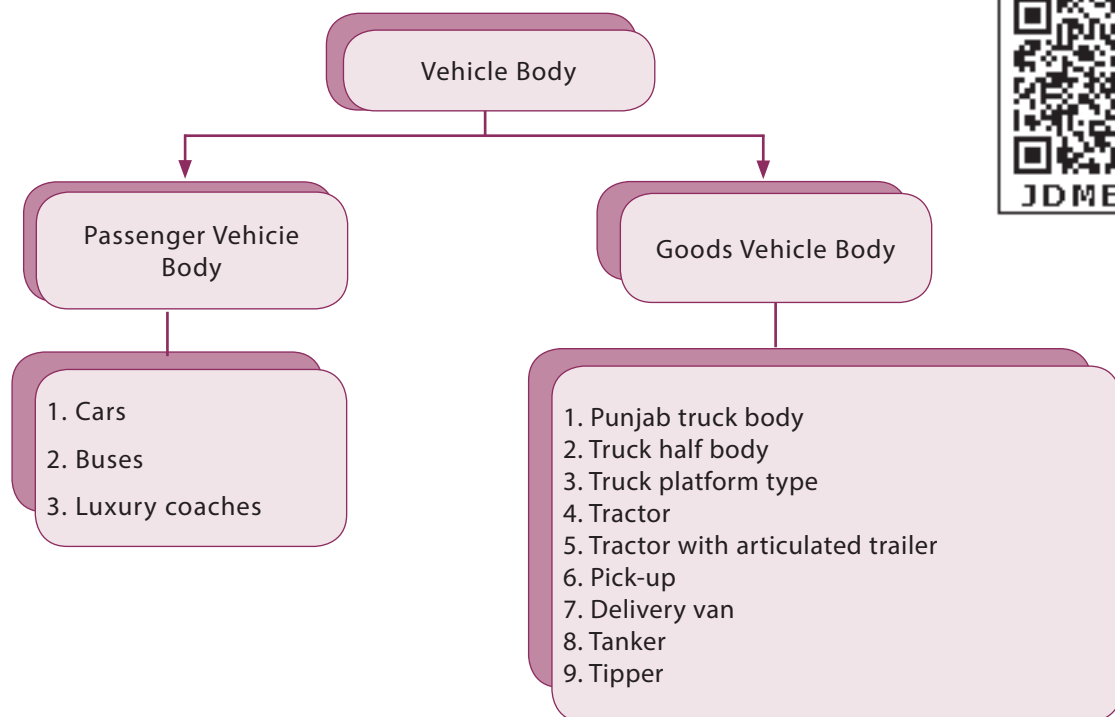

Table 9.4.3 Vehicle body classifications

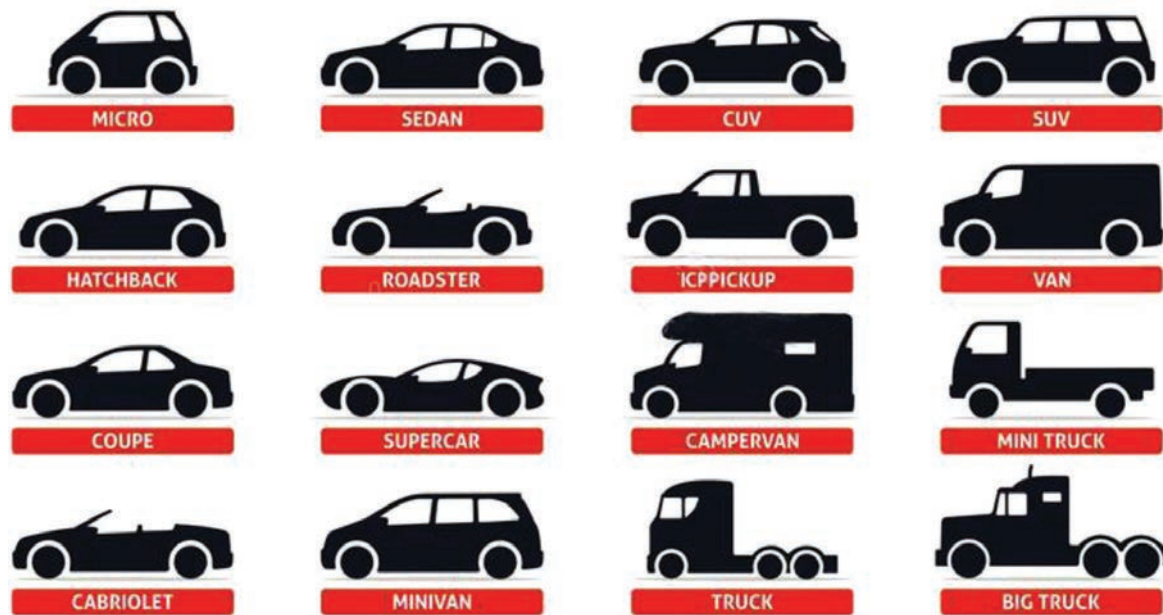

Figure Types of vehicle body

Vehicle type	Other names	Examples of cars in the category
Small car	Hatchback, micro-car, city cars, small family car	Toyota Carolla, Hyundai i10, Mazda2, Nissan Micra, Ford Fiesta
Medium car	Sedan, medium family car	Opel Astra, Ford Fiesta, Hyundai i20
Large car	Saloon, family car	Toyota Camry, Ford Falcon, Audi A6, Ford Mondeo
Sports car	Roadster	Honda CR-V, Mazda MX5, Audi TT
People Mover	Mini van	Toyota Tarago, Chrysler Voyager,
Compact SUV	Mini SUV, Mini 4x4	Hyundai i35, BMW X1, Skoda Yeti
Medium SUV	Large 4x4	Toyota RAV4, Ford Kuga, Mitsubishi Outlander, Jeep Wrangler, Audi Q3
Large SUV	Large 4x4	Toyota Land Cruiser, Mitsubishi Pajero, Hyundai Santa Fe, land Rover Range Rover

Goods Transport

- a. Truck Bodies
- b. Tanker Bodies
- c. Minivan Bodies
- d. Medium load Carrying vehicle
- e. Heavy load carrying Bodies
- f. Three wheeled Bodies.
- g. Tipper bodies.



9.5 Tinkering and painting

9.5.1 Tinkering



Figure 9.5.1 Tinkering

Tinkering is performed to remove dents, scratches, chemical erosion, environmental erosion occurred on the exterior surface. This will improve the aesthetic appearance of the vehicle.

9.5.2 Tools used for tinkering

1. Gas and Arc welding unit
2. Alloy steel sheets
3. New chassis sub frame to be replaced
4. Sheet metal cutter
5. Spray painting gun
6. Required matching colour
7. Thinner
8. Emery sheet
9. Cleaning clothes
10. Patti and scrapper
11. Wood hammer (or) mallet

9.5.3 Painting

Painting on vehicle bodies are used for both surface protection from corrosion and decoration purposes.



Figure 9.5.3 Painting

Steps followed in painting

1. Preparation
 2. Primer
 3. Base coat
 4. Clear coat
 5. Polishing
- Wash the area to be painted with plain water and soap and scrub off any deposits with a micro fibre cloth. Allow the surface to be dried.
 - Remove badges, trims, door handles, side-indicator lamps, headlights, windscreen etc that will hinder the paint job using right tools.
 - Remove the dents using wooden hammer.
 - Finish doing the dent work for the area to be painted. Use emery sheet to clean any rust on the area to be painted. If any new metal is welded, then ground the weld seam. Treat rusted areas with corrosion protection spray (optional).
 - Fill in small imperfections with body filler, and sand back the surface with smooth grades of emery paper, until the surface is smoothed out.
 - Mask the surrounding area with Brown paper.

- Degrease the surface to be painted using a degreaser and wipe the surface free of dust.
- Apply the primer and allow it to dry.
- Apply 2 - 3 base coat with the required matched colour evenly on the surface using spray gun. Ensure complete dryness between each coat.
- Apply the 1 - 2 clear coat to form a glossy and transparent coating and allow it to dry.
- Polish the painted surface.
- Inspect for any paint run and gently remove these with thinner.
- Finally remove all masking from the car.
- Then wash it thoroughly and wax when dry.

9.5.4 Precautions to be followed during tinkering and painting

1. Before tinkering, the vehicle must be raised to the required height by jack and firmly parked.
2. Axles and wheels in the vehicle should be removed
3. Remove the fuel tank, lubrication oil sump and other fluids in the vehicle.
4. All electricity circuits must be securely grounded.
5. Clean the vehicle with compressed air
6. Grease and Wax sticking on the vehicle surface should be cleaned using degreaser
7. The area to be painted should be washed and dried thoroughly.



- It takes 15 ml of gasoline to start the average vehicle.



- It takes about 25 hours to build a car, a whopping 10 hours of that 25 is spent painting the car.



Student Activity

1. Students are advised to submit a report based on the visit at automobile body building shop on various chassis subsystems.
2. Students are advised to submit a report based on the visit at automobile body building shop on mounting body over the chassis frame and various mounting methods.

1.	Chassis Frame	-	அடிச்சட்டம்
2.	Chassis	-	அடித்தளம்
3.	Body	-	மேற்கூடு
4.	Integral	-	ஒருங்கிணைந்த
5.	Static Load	-	நிலைப்பளு
6.	Construction	-	கட்டுமானம்
7.	Wheel base	-	இருசு இடைத்தூரம்
8.	Resistance	-	தடை
9.	Gradient	-	சரிவு
10.	Immerse	-	மூழ்குவி



References

1. S.K. Gupta, A Text Book of Automobile Engineering, S. Chand and Company, New Delhi, ISBN 978-93-837-4691-0, First Edition 2014, Reprint 2016.
2. Automobile Engineering, 2nd Edition, Sci Tech Publications (India) Pvt Ltd, 2011. Ramalingam. K.K.
3. Kirpal Singh, Automobile Engineering, Vol 1, Standard Publisher and distributor, ISBN - 13 - 978-8180141966
4. Jack Erjavec- Automotive Technology_ A Systems Approach -Delmar Cengage Learning (2009) ISBN-13: 978-1428311497
5. James D. Halderman, Automotive Technology, Principles, Diagnosis and service, fourth Edition, 2012, Prentice Hall, ISBN - 3: 978-0-13-254261-6
6. K.K.Jain and R.B.Asthana, Automobile Engineering, Tata McGraw-Hill Publishing Company Limited, New Delhi
7. R.K.Rajput, A Text Book of Automobile Engineering, Laxmi Publications, New Delhi.
8. A.K. Babu & Er. Ajit Pal Singh, Automobile Engineering, S.Chand Publishing, New Delhi
9. Internal Combustion Engines by V. Ganesan, Tata McGraw-Hill Education, 2004
10. Automotive Mechanics by William Crouse, Donald Anglin



Webliography

1. <http://www.mechanicalbooster.com/2014/02/what-is-chassis-in-automobile-how-many-types-of-car-according-to-the-body-style.html>
2. <https://autokeeda.wordpress.com/2015/03/28/various-loads-acting-on-frame/>
3. <https://www.pressmark.co.uk/chassis-manufacturing-process/>
4. <https://info.japanesecartrade.com/content-item/237-classification-of-cars-on-the-basis-of-body-type>
5. <https://www.popularmechanics.com/cars/how-to/a3110/a-diy-guide-to-painting-your-car-15998013/>
6. <https://www.thoughtco.com/auto-body-dent-repair-281389>

Evaluation

PART - A



One mark questions

Choose the correct answer

1. The metal used for manufacturing of chassis frame is _____
 - a. Alloy steel
 - b. Rubber
 - c. Asbestos
 - d. Wood powder
2. Chassis frames are classified into _____ types
 - a. 2
 - b. 3
 - c. 4
 - d. 5
3. In heavy vehicles, _____ type of chassis frame is used.
 - a. Conventional frame
 - b. Semi – integral frame
 - c. Integral frame
 - d. None of the above
4. An automobile without body is called as
 - a. Frame
 - b. Clutch
 - c. Body
 - d. Chassis
5. The distance between the two front wheels is called as
 - a. Wheel base
 - b. Wheel track
 - c. Ground clearance
 - d. Overall width
6. The vehicle part which prevent the passenger from sunlight, rain, dust is known as
 - a. Frame
 - b. Windshield wiper
 - c. Body
 - d. Transmission system

7. The backbone of the automobile is _____
 - a. Chassis frame
 - b. Body
 - c. Engine
 - d. Differential
8. The chassis in which the body and the frame are acting as a single unit is known as
 - a. Conventional frame
 - b. Semi – integral frame
 - c. Integral frame
 - d. Chassis frame
9. The complete vehicle is obtained when _____ is integrated with the chassis frame.
 - a. Windshield wiper
 - b. Differential
 - c. Body
 - d. Electrical accessories
10. Generally, vehicle bodies are classified into _____ types.

a. 2	b. 3
c. 4	d. 5

Part – B

Three mark questions

1. Classify the types of Chassis Frame.
2. What do you mean by Chassis?
3. List any three parts that are mounted on the chassis.
4. List out the materials that are used to manufacture the chassis frame.
5. Define wheelbase.
6. State the functions of vehicle body.
7. What is painting process?

Part – C

Five mark questions

1. Highlight the functions of chassis frame.
2. Draw the chassis frame with indicate the parts
3. Explain the vehicle body and list out the functions.
4. Explain the various parts that are connected to the chassis frame?

Part – D

Ten mark questions

1. Indicate the various loads that are acting on a Chassis Frame.
2. List out the requirements of a vehicle body.
3. Briefly explain about important dimensions of a vehicle.