

# 9

# Definite Integration



## Review of Key Notes and Formulae

1. **Definition:** Let  $f(x)$  be a function defined on an interval  $[a, b]$  and  $F(x)$  be its anti-derivative. Then  $\int_a^b f(x) dx = F(b) - F(a)$  is defined as the definite integral of  $f(x)$  from  $x = a$  to  $x = b$ .

2. **Properties of Definite Integral**

P-1  $\int_a^b f(x) dx = \int_a^b f(t) dt$

P-2  $\int_a^b f(x) dx = -\int_b^a f(x) dx$

P-3  $\int_a^b f(x) dx = \int_a^c f(x) dx + \int_c^b f(x) dx, a < c < b$

P-4  $\int_{-a}^a f(x) dx = \int_0^a [f(x) + f(-x)] dx$

**Very Important**

P-5 **King Property:**  $\int_a^b f(x) dx = \int_a^b f(a + b - x) dx$

P-6 **Queen Property:**  $\int_0^{2a} f(x) dx = \int_0^a \{f(x) + f(2a - x)\} dx$

P-7 **Jack Property:** For a periodic function " $f(x)$ "

(i)  $\int_0^{nT} f(x) dx = n \int_0^T f(x) dx; n \in I$

(ii)  $\int_a^{a+nT} f(x) dx = n \int_0^T f(x) dx; n \in I$

(iii)  $\int_{a+mT}^{a+nT} f(x) dx = \int_m^n f(x) dx = (n - m) \int_0^T f(x) dx; m, n \in I$

(iv)  $\int_{nT}^{a+nT} f(x) dx = \int_0^a f(x) dx$

**P-8** If  $f$  is continuous on  $[a, b]$ , then there exists a number 'c' in  $[a, b]$  at which

$$f(c) = \frac{1}{b-a} \int_a^b f(x) dx$$

↓

Mean value of the function  $f(x)$  on the interval  $[a, b]$

### 3. Leibnitz Rule for Differentiation under Integral Sign

If  $g(x)$  and  $h(x)$  are defined on  $[a, b]$  and differentiable at point  $x \in (a, b)$  and  $f(t)$  is continuous, then

$$\frac{d}{dx} \left( \int_{g(x)}^{h(x)} f(t) dt \right) = f(h(x)) \cdot h'(x) - f(g(x)) \cdot g'(x)$$

### 4. Summation of Series by Definite Integral

**Method:** Replace  $\frac{r}{n}$  by  $x$ ,  $\frac{1}{n}$  by  $dx$  and

Limit of the sum by integral,

$$\int_a^b f(x) dx = \lim_{n \rightarrow \infty} \frac{1}{n} \sum_{r=r_1}^{rn} f\left(\frac{r}{n}\right)$$

where, Lower limit –  $\lim_{n \rightarrow \infty} \frac{r_1}{n} = a$  Upper limit –  $\lim_{n \rightarrow \infty} \frac{rn}{n} = b$ .

### 5. Some Important Results to Remember

$$(i) \int_0^{\pi/2} \sin x dx = \int_0^{\pi/2} \cos x dx = 1$$

$$(ii) \int_0^{\pi/2} \sin^2 x dx = \int_0^{\pi/2} \cos^2 x dx = \frac{\pi}{4}$$

$$(iii) \int_0^{\pi/2} \sin^3 x dx = \int_0^{\pi/2} \cos^3 x dx = \frac{2}{3}$$

$$(iv) \int_0^{\pi/2} \sin^4 x dx = \int_0^{\pi/2} \cos^4 x dx = \frac{3\pi}{16}$$

$$(v) \int_0^{\pi/2} \ln \sin x dx = \int_0^{\pi/2} \ln \cos x dx = \frac{-\pi}{2} \ln 2$$

$$(vi) \int_0^{\pi/2} \ln \tan x dx = \int_0^{\pi/2} \ln \cot x dx = 0$$

$$(vii) \int_0^{\pi/2} \ln \sec x dx = \int_0^{\pi/2} \ln \operatorname{cosec} x dx = \frac{\pi}{2} \ln 2$$



## TIPS AND TRICKS: (T-1)

Short trick to solve integration of the form:

$$\int_a^b \frac{f(x)}{f(x) + f(a+b-x)} dx = \frac{b-a}{2}$$

### Illustration 1

$$\int_0^{\pi/2} \frac{\sqrt{\cot x}}{\sqrt{\cot x} + \sqrt{\tan x}} dx \text{ is equal to}$$



**Short-cut solution :**

$$\boxed{\text{Using T-1}} \because \cot\left(\frac{\pi}{2} - x\right) = \tan x, \text{ Here, } a = 0 \text{ and } b = \frac{\pi}{2}$$

$$\Rightarrow \frac{\frac{\pi}{2} - 0}{2} = \frac{\pi}{4}$$

### Illustration 2

$$\int_0^{\pi} \frac{e^{\cos x}}{e^{\cos x} + e^{-\cos x}} dx \text{ is equal to}$$



**Short-cut solution :**

$$\boxed{\text{Using T-1}} \because \cos(\pi - x) = -\cos x, \text{ Here, } a = 0 \text{ and } b = \pi$$

$$\Rightarrow \frac{\pi - 0}{2} = \frac{\pi}{2}$$



## TIPS AND TRICKS: (T-2)

Short trick to solve integration of the form:

$$\int_0^{\pi} \sin(ax) \cos(bx) dx = \begin{cases} 0 & ; \text{if } a-b \text{ is even} \\ \frac{2a}{a^2 - b^2} & ; \text{if } a-b \text{ is odd} \end{cases}$$

### Illustration 3

$$\int_0^{\pi} \sin(4x) \cos(10x) dx \text{ is equal to}$$



**Short-cut solution :**

Using T-2  $\because a = 4$  and  $b = 10 \Rightarrow a - b$  is even

Hence, answer = 0.

#### Illustration 4

$\int_0^{\pi} \sin(60x) \cos(41x) dx$  is equal to



**Short-cut solution :**

Using T-2  $\because a = 60, b = 41 \Rightarrow a - b$  is odd

Hence, answer =  $\frac{2 \times 60}{3600 - 1681} = \frac{120}{1919}$



### TIPS AND TRICKS: (T-3)

Short trick to solve integration of the form:

$$\int_0^{\pi/2} \frac{dx}{a^2 \cos^2 x + b^2 \sin^2 x} = \frac{\pi}{2ab}$$

#### Illustration 5

$\int_0^{\pi/2} \frac{dx}{25 \cos^2 x + 16 \sin^2 x}$ , is equal to



**Short-cut solution :**

Using T-3  $a = 5$  and  $b = 4$

Hence,  $\frac{\pi}{2ab} = \frac{\pi}{2 \times 5 \times 4} = \frac{\pi}{40}$

#### Illustration 6

$\int_0^{\pi/2} \frac{dx}{10 \sin^2 x + 9 \cos^2 x}$ , is equal to



**Short-cut solution :**

Using T-3  $a = 3$  and  $b = \sqrt{10}$

Hence,  $\frac{\pi}{2ab} = \frac{\pi}{2 \times 3 \times \sqrt{10}} = \frac{\pi}{6\sqrt{10}}$



## TIPS AND TRICKS: (T-4)

Short trick to solve integration of the form:

$$(i) \int_a^b \frac{dx}{\sqrt{(x-a)(b-x)}} = \pi ; b > a$$

$$(ii) \int_a^b \sqrt{(x-a)(b-x)} dx = \frac{\pi}{8} (b-a)^2 ; b > a$$

### Illustration 7

$$\int_2^7 \frac{dx}{\sqrt{(x-2)(7-x)}}, \text{ is equal to}$$



**Short-cut solution :**

$$\text{Using T-4 (i)} \quad \because a=2, b=7 \text{ and } b > a \Rightarrow \pi$$

### Illustration 8

$$\int_{-5}^9 \sqrt{(x+5)(9-x)} dx, \text{ is equal to}$$



**Short-cut solution :**

$$\text{Using T-4 (ii)} \quad \because a=-5, b=9 \text{ and } b > a$$

$$\Rightarrow \frac{\pi}{8} (b-a)^2 = \frac{\pi}{8} (9+5)^2 = \frac{\pi}{8} \times 196 = \frac{49\pi}{2}$$



## TIPS AND TRICKS: (T-5)

Short trick to solve integration of the form:

$$\int_a^b (x-a)^m (b-x)^n dx = (b-a)^{m+n+1} \frac{m!n!}{(m+n+1)!}$$

### Illustration 9

$$\int_1^2 (x-1)^2 (2-x)^3 dx, \text{ is equal to}$$



**Short-cut solution :**

$$\text{Using T-5} \quad \because a=1, b=2, m=2, n=3$$

$$\Rightarrow (b-a)^{m+n+1} \frac{m!n!}{(m+n+1)!} = \frac{(1)^6 2!3!}{6!} = 60$$



## TIPS AND TRICKS: (T-6)

Short trick to solve integration of the form:

$$\int_0^{\pi/2} \sin^m x \cdot \cos^n x dx = \left\{ \frac{((m-1)(m-3) \dots 2 \text{ or } 1) ((n-1)(n-3) \dots 2 \text{ or } 1)}{(m+n)(m+n-2)(m+n-4) \dots 2 \text{ or } 1} \times K \right\}$$

$$\text{where, } K = \begin{cases} \pi/2; & \text{when } m \text{ and } n, \text{ both are even} \\ 1 & ; \text{otherwise} \end{cases}$$

### Illustration 10

$$\int_0^{\pi/2} \sin^4 x dx, \text{ is equal to}$$



**Short-cut solution :**

Using T-6  $\because m = 4, n = 0 \Rightarrow$  both even

$$\text{Hence, } \frac{(4-1)(4-3)}{4(4-2)} \times \frac{\pi}{2} = \frac{3\pi}{16}$$

### Illustration 11

$$\int_0^{\pi/2} \sin^3 x \cos^2 x dx, \text{ is equal to}$$



**Short-cut solution :**

Using T-6  $\because m = 3, n = 2 \Rightarrow$  otherwise

$$\text{Hence, } \frac{(3-1)(2-1)}{5(5-2)(5-4)} = \frac{2}{15}$$

## SHORTCUTS: (SC-1)

If  $\int_a^b f(x) dx = 0$ , then the equation  $f(x) = 0$  has at least one root in  $(a, b)$ ,

provided  $f(x)$  is continuous in this interval.

### Illustration 12

If  $2a + 3b + 6c = 0$ , then prove that the equation  $ax^2 + bx + c = 0$  has a root in  $(0, 1)$ .



**Short-cut solution :**

Using SC-1 Let  $f(x) = ax^2 + bx + c$

$$\Rightarrow \int_0^1 (ax^2 + bx + c) dx = \left[ \frac{ax^3}{3} + \frac{bx^2}{2} + cx \right]_0^1$$

$$0 = \frac{a}{3} + \frac{b}{2} + c \quad \{\because \text{It has a root in } (0, 1)\}$$

$$\Rightarrow 2a + 3b + 6c = 0$$

## SHORTCUTS: (SC-2)

If  $y = f(x)$  and  $x = g(y)$  are inverse of each other and  $f(a) = c, f(b) = d$  then,

$$\int_a^b f(x) dx + \int_c^d g(y) dy = bd - ac$$

### Illustration 13

$$\text{Find: } \int_0^1 e^{\sqrt{e^x}} dx + 2 \int_e^{e\sqrt{e}} \ln(\ln x) dx$$



**Short-cut solution :**

Using SC-2

Since,  $2 \ln(\ln x)$  is inverse of  $e^{\sqrt{e^x}}$  and  $a = 0, b = 1, c = e, d = e\sqrt{e}$

$$\Rightarrow I = bd - ac = 1 \times e\sqrt{e} - 0 \times e = e\sqrt{e}$$

## SHORTCUTS: (SC-3)

Sandwich theorem for Definite Integral.

If we have,  $g(x) \leq f(x) \leq h(x), \forall x \in [a, b]$

$$\Rightarrow \int_a^b g(x) dx \leq \int_a^b f(x) dx \leq \int_a^b h(x) dx$$

### Illustration 14

$$\text{If } \frac{\pi}{A} < \int_{\pi/4}^{\pi/2} (\sin x)^{10} dx < \frac{\pi}{B} \text{ then } A + B \text{ is}$$



**Short-cut solution :**

Using SC-3 Since,  $\frac{1}{\sqrt{2}} \leq \sin x \leq 1$

$$\text{Hence, } \int_{\pi/4}^{\pi/2} \frac{1}{32} dx < \int_{\pi/4}^{\pi/2} (\sin x)^{10} dx < \int_{\pi/4}^{\pi/2} 1 \cdot dx$$

$$\Rightarrow \frac{\pi}{128} < \int_{\pi/4}^{\pi/2} (\sin x)^{10} dx < \frac{\pi}{4}$$

Hence  $A + B = 128 + 4 = 132$ .

## SHORTCUTS: (SC-4)

Solving definite integration using graph.

Take area above  $x$ -axis be positive and area below  $x$ -axis be negative and then find the algebraic sum of the area.

### Illustration 15

$\int_{\pi/2}^{3\pi/2} [2 \sin x] dx$ , is equal to (where,  $[x]$  is greatest integer function)



**Short-cut solution :**

Using SC-4  $\therefore I = \frac{\pi}{3} - \left(\frac{\pi}{6}\right) - \left(\frac{2\pi}{3}\right) = -\frac{\pi}{2}$

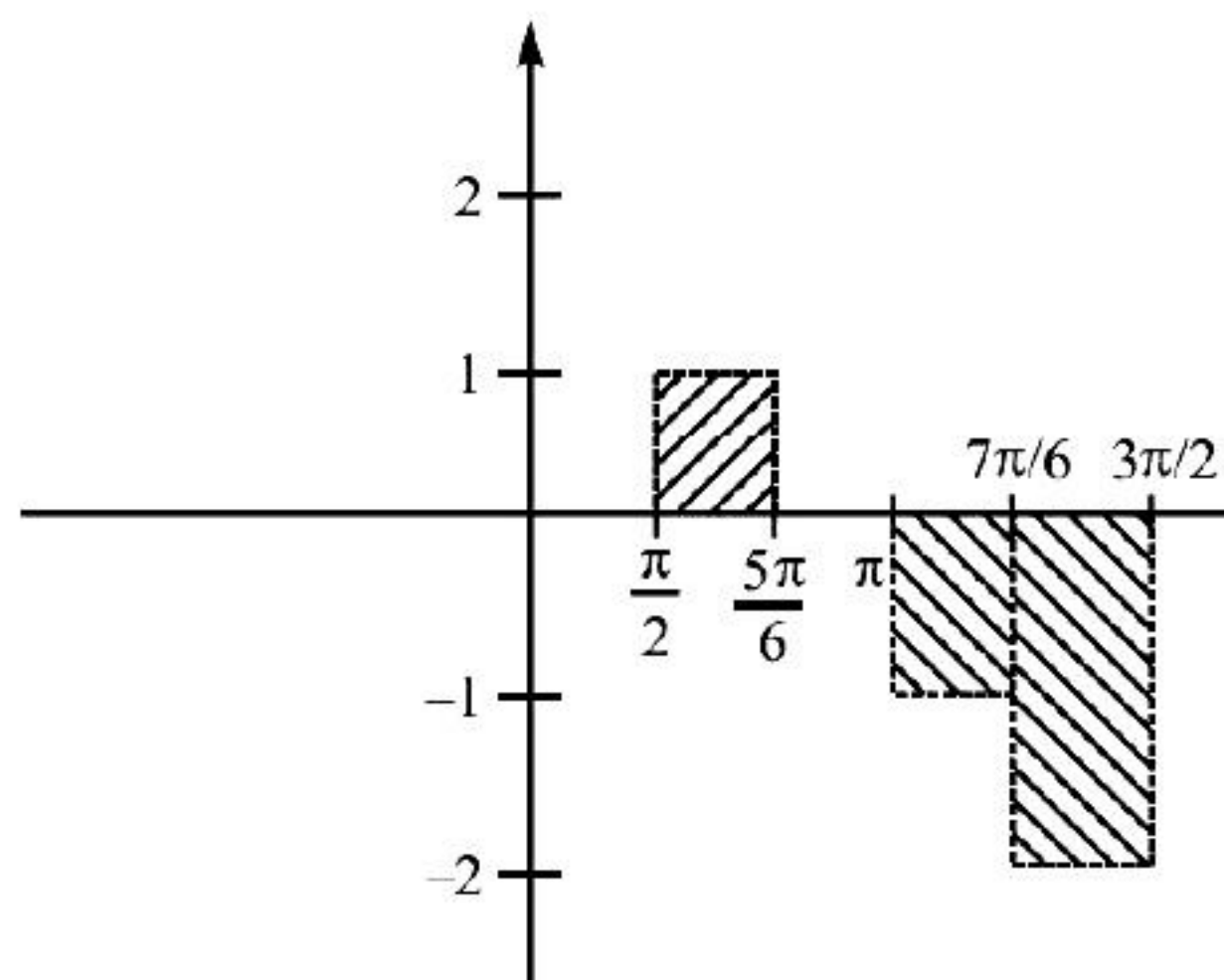

## TECHNIQUE

Transfer one integration in other by proper substitution.

$$\int_a^b f(x)dx = (b-a)\int_0^1 f((b-a)x+a)dx$$

### Illustration 16

Find the transformation of  $3\int_{1/3}^{2/3} e^{9\left(x-\frac{2}{3}\right)^2} dx$



**Short-cut solution :**

Using Tech.

$$3\int_{1/3}^{2/3} e^{9\left(x-\frac{2}{3}\right)^2} dx = 3\left[\left(\frac{2}{3}-\frac{1}{3}\right)\right]\int_0^1 e^{9\left[\left(\frac{2}{3}-\frac{1}{3}\right)x+\frac{1}{3}-\frac{2}{3}\right]^2} dx$$

$$= \int_0^1 e^{9\left(\frac{x-1}{3}\right)^2} dx$$

$$= \int_0^1 e^{(x-1)^2} dx$$

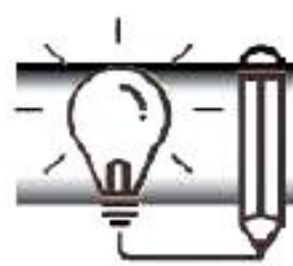

## Concept Booster Exercise

1. The integral  $\int_2^4 \frac{\log x^2}{\log x^2 + \log(36 - 12x + x^2)} dx$  is equal to [JEE M 2015]  
(a) 2 (b) 4 (c) 1 (d) 6
2. The value of the integral  $\int_{\pi/6}^{\pi/3} \frac{dx}{1 + \sqrt{\tan x}}$  is equal to [JEE M 2013]  
(a)  $\pi/6$  (b)  $\pi/12$  (c)  $\pi/3$  (d)  $\pi/2$
3. The value of the integral  $\int_0^{\pi} \sin 2x \cdot \cos 20x dx$  is equal to  
(a) 1 (b) 0 (c)  $\frac{2}{99}$  (d)  $-\frac{2}{99}$
4. The value of the integral  $\int_0^{\pi/2} \frac{dx}{49\sin^2 x + 11\cos^2 x}$  is equal to  
(a)  $\pi/14\sqrt{11}$  (b)  $\pi/\sqrt{11}$  (c)  $\pi/14$  (d)  $\pi/12\sqrt{11}$
5. The integral  $\int_{-2}^{+3} \sqrt{(x+2)(-x+3)} dx$  is equal to  
(a)  $\frac{25\pi}{2}$  (b)  $\frac{25\pi}{4}$  (c)  $\frac{24\pi}{5}$  (d)  $\frac{25\pi}{8}$
6. The integral  $\int_3^6 \frac{dx}{\sqrt{(x-3)(6-x)}}$  is equal to  
(a)  $\pi$  (b)  $\frac{\pi}{2}$  (c)  $2\pi$  (d)  $-\pi$
7.  $\int_3^5 (x-3)^2 (5-x)^3 dx$  is equal to  
(a)  $\frac{15}{16}$  (b)  $\frac{14}{15}$  (c)  $\frac{16}{13}$  (d)  $\frac{16}{15}$
8. The value of the integral  $\int_0^{\pi/2} \sin^2 x \cos^3 x dx$ , is  
(a)  $\frac{2}{6}$  (b)  $\frac{2}{15}$  (c)  $\frac{15}{2}$  (d)  $\frac{3}{2}$

9. The value of the integral  $\int \sin^4 x \cos^6 x dx$  is

- (a)  $\frac{3}{25} \cdot \frac{\pi}{2}$       (b)  $\frac{3}{26} \cdot \frac{\pi}{2}$       (c)  $\frac{3}{256} \cdot \frac{\pi}{2}$       (d)  $\frac{3}{625} \cdot \frac{\pi}{2}$

10. If  $2a + 9b + 12c = 0$ , then the equation  $ax^2 + 3bx + 2c = 0$  has a root in

- (a) (0, 2)      (b) (0, 3)      (c) (0, 4)      (d) (0, 1)

11. The value of  $\int_1^2 e^x dx + \int_e^{e^2} \ln x dx$  is equal to

- (a)  $e - 2e^2$       (b)  $2e^2 - e$       (c)  $2e^2$       (d)  $2e$

12. Let  $f(x) = x - [x]$ , for every real number  $x$ , where  $[x]$  is the integral part of  $x$ .

Then  $I = \int_{-1}^1 f(x) dx$  is

- (a) 1      (b) 2      (c) 0      (d)  $-\frac{1}{2}$

13. The value of  $\int_2^3 \frac{\sqrt{x}}{\sqrt{5-x} + \sqrt{x}} dx$  is equal to

- (a)  $\frac{1}{3}$       (b)  $\frac{1}{4}$       (c)  $\frac{1}{2}$       (d) 1

14. The value of  $\int_0^{2n\pi} \max.(\sin x, \sin^{-1} \sin x) dx$  is equal to

- (a)  $n\left(\frac{\pi^2}{2} - 8\right)$       (b)  $n\left(\frac{\pi^2}{4} - 8\right)$       (c)  $n(\pi^2 - 8)$       (d)  $n\left(\frac{\pi^2}{3} - 8\right)$

15. Find the value of  $\int_{\alpha}^{\beta} \frac{dx}{\sqrt{(x-\alpha)(\beta-x)}}$ ;  $\beta > \alpha$  is equal to

- (a)  $\frac{\pi}{2}$       (b)  $\pi$       (c)  $\frac{\pi}{8} (\beta - \alpha)^2$       (d)  $2\pi$

### NUMERICAL VALUE PROBLEMS

16. The value of the integral  $\int_{-1}^3 \left[ x + \frac{1}{2} \right] dx$  is equal to (where,  $[x]$  is greatest integer function)

17. If  $K_1 < \int_0^{\pi/2} \frac{\sin x}{x} dx < \frac{\pi}{K_2}$ , then the value of  $K_1 + K_2$  is equal to



## Solutions

1. (c) **Using T-1** Since,  $a = 2$ ,  $b = 4$

$$\Rightarrow I = \frac{b-a}{2} = \frac{4-2}{2} = 1$$

2. (b) **Using T-1**  $I = \int_{\pi/6}^{\pi/3} \frac{\sqrt{\cos x}}{\sqrt{\cos x} + \sqrt{\sin x}} dx$

$$\text{Here, } a = \frac{\pi}{6}, \quad b = \frac{\pi}{3}$$

$$\Rightarrow I = \frac{b-a}{2} = \frac{\frac{\pi}{3} - \frac{\pi}{6}}{2} = \frac{\pi}{12}$$

3. (b) **Using T-2**  $\because a = 2$ ,  $b = 20 \Rightarrow b - a = 18$  is even  
Hence, answer = 0

4. (a) **Using T-3**  $\because a = 7$ ,  $b = \sqrt{11}$

$$\Rightarrow I = \frac{\pi}{2ab} = \frac{\pi}{14\sqrt{11}}$$

5. (d) **Using T-4(ii)**

$$\Rightarrow a = -2, \quad b = 3 \Rightarrow I = \frac{\pi}{8}(b-a)^2 = \frac{\pi}{8}(5)^2 = \frac{25\pi}{8}$$

6. (a) **Using T-4(i)**  $\because a = 3$ ,  $b = 6$  ( $b > a$ )

$$\Rightarrow \pi$$

7. (d) **Using T-5**  $\because a = 3$ ,  $b = 5$ ,  $m = 2$ ,  $n = 3$

$$\Rightarrow I = (b-a)^{m+n+1} \cdot \frac{m!n!}{(m+n+1)!} = (5-3)^6 \cdot \frac{2!3!}{6!} = \frac{16}{15}$$

8. (b) **Using T-6**  $\because m = 2$ ,  $n = 3$  (Both not even)

$$\Rightarrow I = \frac{(2-1)(3-1)}{5(5-2)(5-4)} = \frac{2}{15}$$

9. (c) **Using T-6**  $\because m = 4$ ,  $n = 6$  (Both even)

$$\Rightarrow I = \frac{(4-1)(4-3)(6-1)(6-3)(6-5)}{10(10-2)(10-4)(10-6)(10-8)} \times \frac{\pi}{2} = \frac{3}{256} \cdot \frac{\pi}{2}$$

10. (d) Using SC-1 Let  $f(x) = ax^2 + 3bx + 2c$

$$\Rightarrow \int_0^1 (ax^2 + 3bx + 2c) dx = \left[ \frac{ax^3}{3} + \frac{3bx^2}{2} + 2cx \right]_0^1 = \frac{6a + 9b + 12c}{6}$$

Since,  $6a + 9b + 12c = 0$  (given). Hence root will lie in  $(0, 1)$ .

11. (b) Using SC-2 Since  $\ln x$  is inverse of  $e^x$

$$\Rightarrow I = bd - ac = 2e^2 - 1 \times e = 2e^2 - e$$

12. (a) Using SC-4  $\because f(x) = x - [x] = \{x\}$

Now, Drawing graph of  $y = \{x\}$

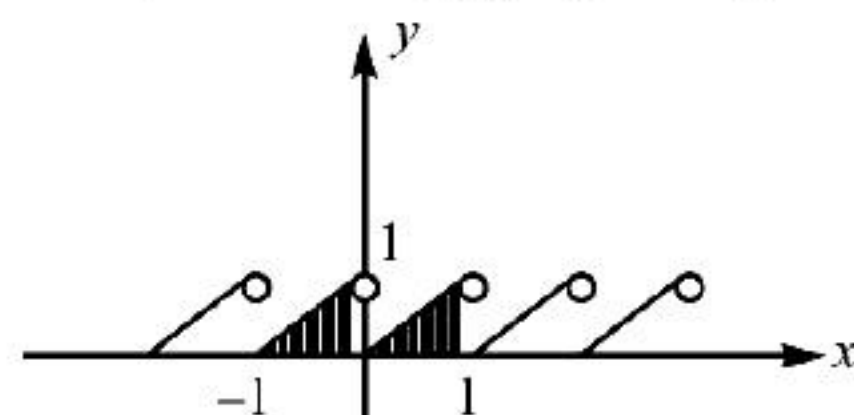

$$\Rightarrow I = \frac{1}{2} \times 1 \times 1 + \frac{1}{2} \times 1 \times 1$$

$$\Rightarrow \boxed{I=1}$$

13. (c) Using T-1  $\because f(x) = \sqrt{x}, f(a+b-x) = \sqrt{5-x}$

$$\Rightarrow I = \frac{b-a}{2} = \frac{3-2}{2} = \frac{1}{2}$$

14. (b)  $\because$  Using P-7(i)

$$I = n \int_0^{2\pi} \max. \{ \sin x, \sin^{-1} \sin x \} dx \quad \left( \because y = \sin x \text{ is periodic with period } '2\pi' \right)$$

$$\Rightarrow I = n \left[ \int_0^{\pi} \sin^{-1}(\sin x) dx + \int_{\pi}^{2\pi} \sin x dx \right]$$

$$\text{Hence, } I = n \left[ \frac{1}{2} \times \pi \times \frac{\pi}{2} - 2 \right]$$

$$\Rightarrow I = n \left( \frac{\pi^2}{4} - 8 \right)$$

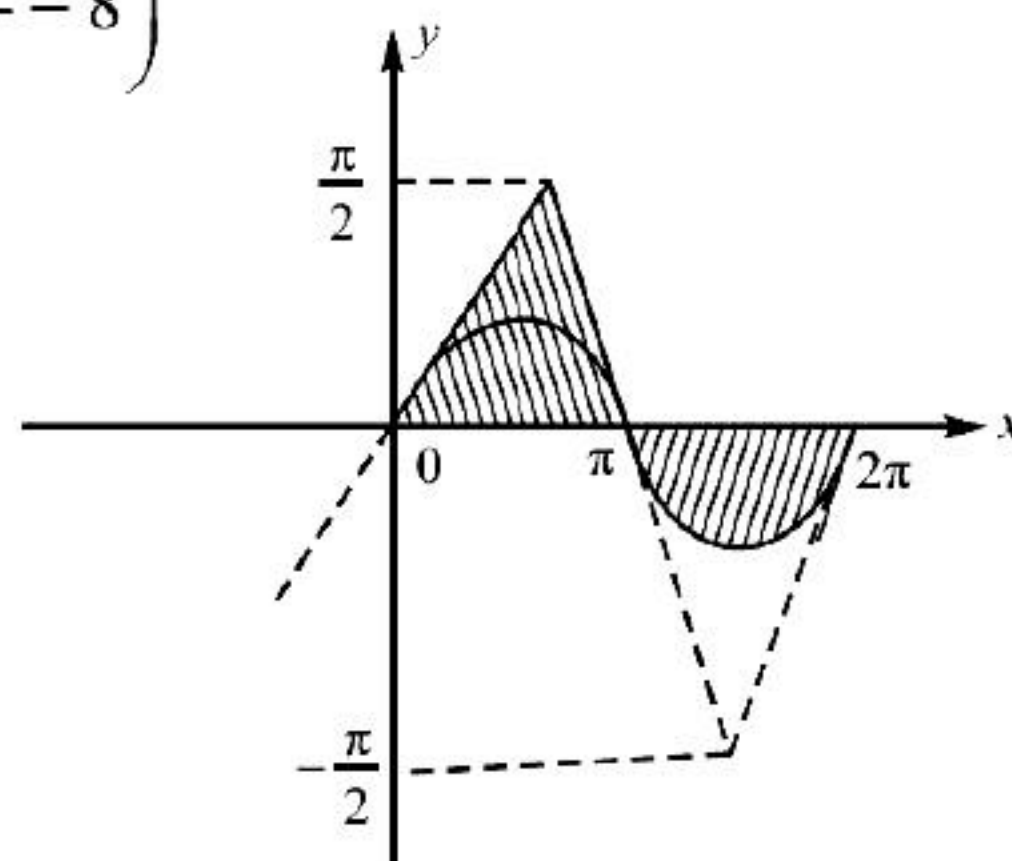

15. (b) Using T-4(i)  $a = \alpha, b = \beta$  ( $\because b > a$ ) given  
 $\Rightarrow \pi$

16. (4) Using SC-4 Drawing graph  
 We will find area of shaded portion

$$\Rightarrow I = \left(1 + 2 + \frac{3}{2} - \frac{1}{2}\right) \Rightarrow I = 4$$

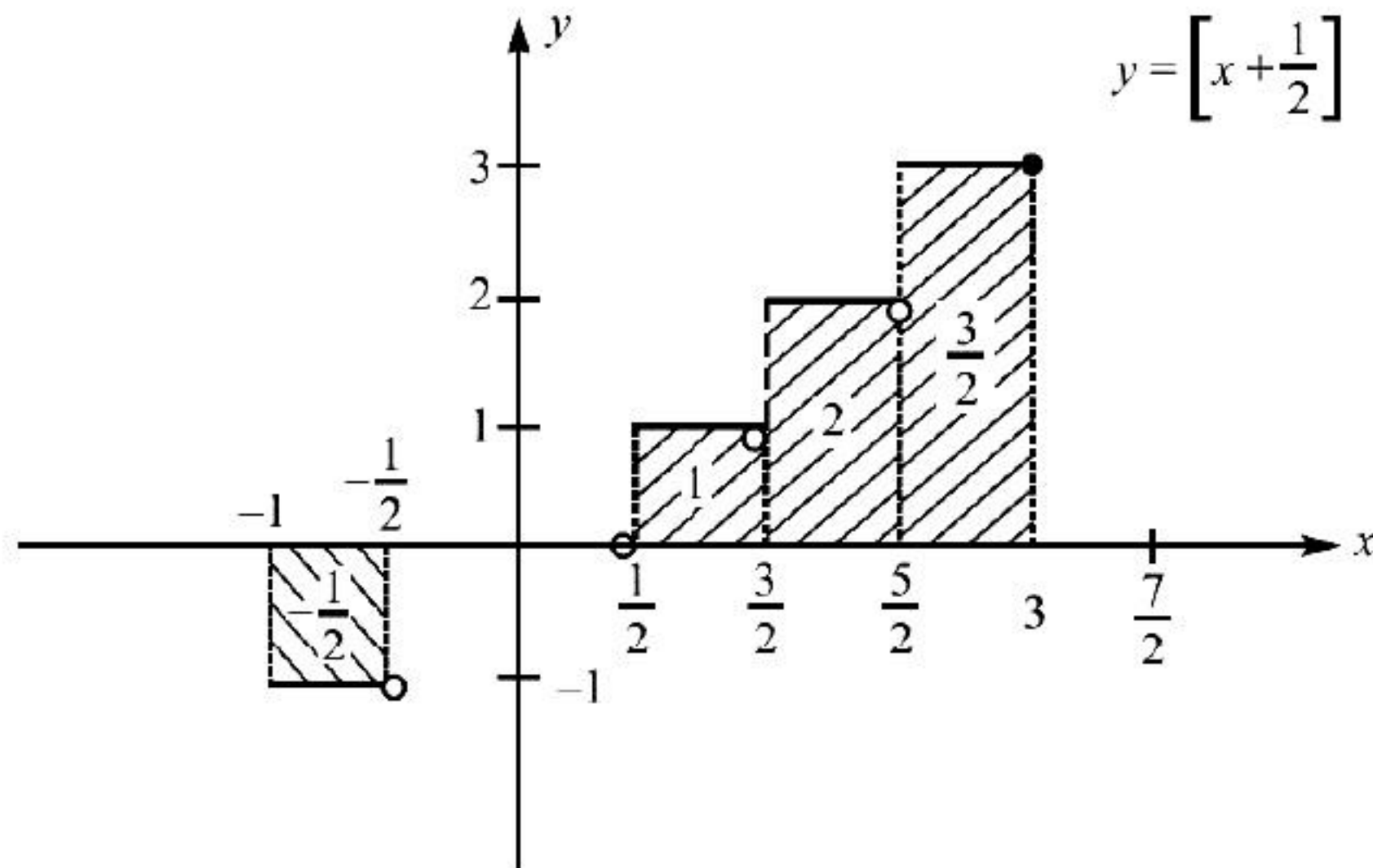

17. (3) Using SC-3 For  $x \in \left[0, \frac{\pi}{2}\right]$

As we know,  $\frac{2}{\pi} < \frac{\sin x}{x} < 1$

$$\Rightarrow \int_0^{\pi/2} \frac{2}{\pi} < \int_0^{\pi/2} \frac{\sin x}{x} dx < \int_0^{\pi/2} dx \Rightarrow 1 < \int_0^{\pi/2} \frac{\sin x}{x} dx < \frac{\pi}{2}$$

$$\Rightarrow K_1 = 1, K_2 = 2 \Rightarrow K_1 + K_2 = 3.$$