

5

Light-Reflection and Refraction

Multiple Choice Questions (MCQs)

DIRECTIONS : This section contains multiple choice questions. Each question has four choices (a), (b), (c) and (d) out of which only one is correct.

- An object is at a distance of 0.5 m in front of a plane mirror. Distance between the object and image is
 - 0.5 m
 - 1 m
 - 0.25 m
 - 1.5 m
- Number of images formed when two plane mirrors are inclined at an angle 90° is
 - 3
 - 2
 - 4
 - 5
- Which one of the following statements is not correct?
 - A convex mirror is often used as driving rear-view mirror.
 - A convex mirror is often used as a shaving mirror.
 - A concave mirror is often used in a search light or a torch.
 - A concave mirror is often used as the reflector behind lamp in a projector
- The relation, $R = 2f$ holds true for :
 - concave mirrors only
 - convex mirrors only
 - all spherical mirrors
 - lens as well as for all spherical mirrors.
- A magnification greater than unity indicates :
 - real image
 - size of the image is smaller than that of object
 - size of the object is smaller than that of image
 - size of object is equal to that of image
- The image formed by a convex mirror
 - is always real
 - is always virtual
 - cannot say
 - None of these
- In case of erect object having inverted image, linear magnification is :
 - positive
 - negative
 - zero
 - no definite sign.
- If object lies symmetrically and number of images formed are 9, therefore two plane mirrors are kept at an angle of :
 - 72°
 - 40°
 - 36°
 - 50°
- Reciprocal of focal length of a lens gives the
 - power
 - radius
 - magnification
 - none of these
- Magnification of a lens is given by
 - $\frac{\text{image height}}{\text{object height}}$
 - $\frac{1}{\text{Radius}}$
 - $\frac{1}{\text{focal length}}$
 - $\frac{1}{\text{image distance}}$
- A man having height 2.5 m. He observes image of 1m height erect, then mirror used is
 - concave
 - convex
 - plane
 - None of these
- Where should an object be placed in front of a convex lens to get a real image of the size of the object?
 - At the principal focus of the lens
 - At twice the focal length
 - At infinity
 - Between the optical centre of the lens and its principal focus.

Light-Reflection and Refraction

13. Find the angle of incidence and angle of reflection from the diagram.

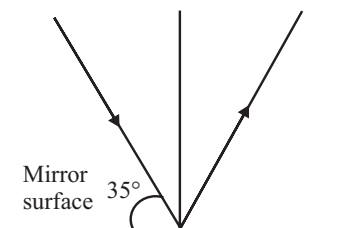

- (a) $45^\circ, 40^\circ$ (b) $55^\circ, 55^\circ$
 (c) $60^\circ, 60^\circ$ (d) $30^\circ, 30^\circ$
14. A spherical mirror and a thin spherical lens have each a focal length of -15 cm. The mirror and the lens are likely to be
- (a) both concave.
 (b) both convex.
 (c) the mirror is concave and the lens is convex.
 (d) the mirror is convex, but the lens is concave.
15. Which of the following lenses would you prefer to use while reading small letters found in a dictionary?
- (a) A convex lens of focal length 50 cm.
 (b) A concave lens of focal length 50 cm.
 (c) A convex lens of focal length 5 cm.
 (d) A concave lens of focal length 5 cm.
16. An object is situated at a distance of $f/2$ from a convex lens of focal length f . Distance of image will be –
- (a) $+ (f/2)$ (b) $+ (f/3)$
 (c) $+ (f/4)$ (d) $-f$
17. An object is placed 60 cm in front of a concave mirror. The real image formed by the mirror is located 30 cm in front of the mirror. What is the object's magnification?
- (a) $+2$ (b) -2
 (c) $+0.5$ (d) -0.5
18. Two plane mirrors are set at right angle and a flower is placed in between the mirrors. The number of images of the flower which will be seen is
- (a) One (b) Two
 (c) Three (d) Four
19. A man is 6.0 ft tall. What is the smallest size plane mirror he can use to see his entire image
- (a) 3.0 ft (b) 6.0 ft
 (c) 12 ft (d) 24 ft

20. An object is placed 60 cm in front of a convex mirror. The virtual image formed by the mirror is located 30 cm behind the mirror. What is the object's magnification
- (a) $+2$ (b) -2
 (c) $+0.5$ (d) -0.5

21. Light rays *A* and *B* fall on optical component *X* and come out as *C* and *D*.

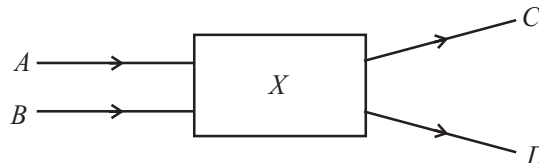

The optical component is a

- (a) concave lens (b) convex lens
 (c) convex mirror (d) prism
22. An object is placed 20.0 cm in front of a concave mirror whose focal length is 25.0 cm. What is the magnification of the object?
- (a) $+5.0$ (b) -5.0
 (c) $+0.20$ (d) -0.20
23. An object is placed at the radius of curvature of a concave spherical mirror. The image formed by the mirror is
- (a) located at the focal point of the mirror.
 (b) located between the focal point and the radius of curvature of the mirror.
 (c) located at the center of curvature of the mirror.
 (d) located out beyond the center of curvature of the mirror.
24. If the refractive indices for water and diamond relative to air are 1.33 and 2.4 respectively, then the refractive index of diamond relative to water is –
- (a) 5.5 (b) 1.80
 (c) 3.19 (d) None of these
25. There is an equiconvex lens of focal length of 20 cm. If the lens is cut into two equal parts perpendicular to the principle axis, the focal lengths of each part will be
- (a) 20 cm (b) 10 cm
 (c) 40 cm (d) 15 cm
26. An object is placed 20.0 cm in front of a concave mirror whose focal length is 25.0 cm. Where is the image located?
- (a) 1.0×10^2 cm in front of the mirror
 (b) 1.0×10^2 cm behind the mirror
 (c) 5.0×10^1 cm in front of the mirror
 (d) 5.0×10^1 cm behind the mirror

27. Which statement best describes the property of light waves illustrated in the diagram below?

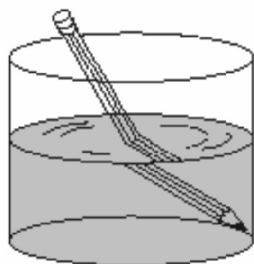

- (a) Some materials absorb light waves.
 (b) Some materials reflect light waves.
 (c) Light waves are refracted by some materials.
 (d) Light waves are emitted by some materials.
28. Light waves
- (a) require air or another gas to travel through
 (b) require an electric field to travel through
 (c) require a magnetic field to travel through
 (d) can travel through perfect vacuum
29. What are the factors that determine the angle of deviation in a prism?
- (a) angle of incidence (b) wave length
 (c) angle of the prism (d) All the above
30. Morning sun is not so hot as the mid day sun because
- (a) Sun is cooler in the morning
 (b) Heat rays travel slowly in the morning
 (c) It is God gift
 (d) The sun's rays travel a longer distance through atmosphere in the morning
31. The layered lens shown below is made of two different transparent materials.

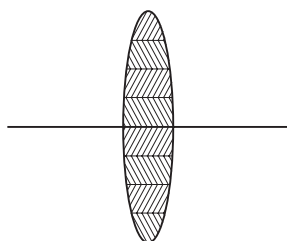

A point object is placed on its axis. The object will form

- (a) one image (b) infinite images
 (c) no image (d) two images
32. An object is placed in front of a concave mirror of focal length 50.0 cm and a real image is formed 75 cm in front of the mirror. How far is the object from the mirror
- (a) 25 cm (b) 30 cm
 (c) 150 cm (d) -150 cm
33. A number of images of a candle flame can be seen in a thick plane mirror. The brightest image is
- (a) Fourth (b) Second
 (c) Last (d) First
34. A ray from air enters water, then through a thick layer of glass placed below water. After passing through glass, it again comes out in air medium. Then final emergent ray will
- (a) Bend towards the normal
 (b) Suffer lateral displacement
 (c) Have the same path as if it had not passed through glass and water.
 (d) None of these
35. A concave spherical mirror has a radius of curvature of 100 cm. What is its focal length
- (a) 50 cm (b) 100 cm
 (c) 200 cm (d) 300 cm
36. Light is incident on an air-water interface at an angle of 25° to the normal. What angle does the refracted ray make with the normal
- (a) 19° (b) 34°
 (c) 25° (d) 90°
37. If the speed of light in medium -1 and medium -2 are $2.5 \times 10^8 \text{ ms}^{-1}$ and $2 \times 10^8 \text{ ms}^{-1}$, respectively, then the refractive index of medium - 1 with respect to medium - 2 is _____.
- (a) $\frac{3}{2.5}$ (b) $\frac{2}{2.5}$
 (c) $\frac{2.5}{3}$ (d) $\frac{2.5}{2}$
38. Under what conditions does a diverging lens form a virtual image of a real object
- (a) Only if $u > f$.
 (b) Only if $u < f$.
 (c) Only if $u = f$
 (d) A diverging lens always forms a virtual image of a real object.
39. A lens produces an enlarged, virtual image. What kind of lens is it?
- (a) converging
 (b) diverging
 (c) It could be either diverging or converging.
 (d) None

Light-Reflection and Refraction

40. In an experiment to determine the focal length of a concave lens, a student obtained the image of a distant window on the screen. To determine the focal length of the lens, she/he should measure the distance between the
- lens and the screen only
 - lens and the window only
 - screen and the window only
 - screen and the lens and also between the screen and the window

41. Ashima looks into the mirror and sees the reflection of the picture behind her.

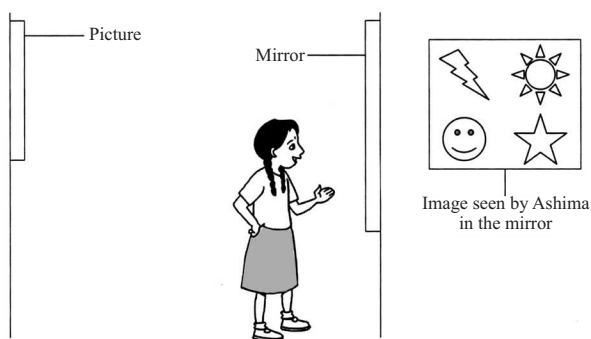

Which of the following is the picture that is behind Ashima?

-
-
-
-

42. On the basis of experiment 'to trace the path of a ray of light passing through a rectangular glass slab' four students arrived at the following interpretations :
- Angle of incidence is greater than the angle of emergence.
 - Angle of emergence is less than the angle of refraction.
 - Emergent ray is parallel to the incident ray.
 - Emergent ray is parallel to the refracted ray.

The correct interpretation is that of the student.

- I
 - II
 - III
 - IV
43. Light waves
- are mechanical waves
 - are electromagnetic waves
 - travel with the same velocity in all media
 - requires a material medium for their propagation
44. Virtual images of object of the same size are formed by
- a concave mirror
 - a convex mirror
 - a plane mirror
 - all the above
45. Two plane inclined mirrors form 5 images by multiple reflection. The angle of inclination is
- 90°
 - 60°
 - 45°
 - 30°
46. A bright \times (cross) mark is made on a sheet of white paper. Over the white paper a rectangular glass-slab of thickness 3 cm is placed. On looking through, the image of the mark appears above the mark. It is below the upper surface of the slab by ($\mu_{\text{glass}} = 1.5$)
- 2.5 cm
 - 1.5 cm
 - 2 cm
 - 1.75 cm
47. Images formed by an object placed between two plane mirrors whose reflecting surfaces make an angle of 90° with one another lie on a
- Straight line
 - Zig-zag curve
 - Circle
 - Ellipse
48. A diver in a swimming pool wants to send a signal to a person lying on the edge of the pool by flashing his waterproof torch
- He must direct the beam of light vertically upwards
 - He must direct the beam horizontally
 - He must direct the beam at an angle to the vertical which is slightly lesser than the critical angle
 - He must direct the beam at an angle to the vertical which is slightly greater than the critical angle

49. Two plane mirrors are inclined at an angle θ . A ray of light is incident on one mirror and is then reflected from the other mirror. Then the angle between the first ray and the final ray will be

- (a) θ (b) 2θ
 (c) between θ and 2θ (d) $> 2\theta$
50. A glass slab is placed in the path of a beam of convergent light, then the point of convergence of light
 (a) moves towards the glass slab
 (b) moves away from the glass slab
 (c) remains at the same point
 (d) undergoes a lateral shift
51. A real image is formed by a convex mirror when the object is placed at
 (a) infinite
 (b) between center of curvature and focus
 (c) between focus and pole
 (d) None of the above
52. A virtual image is formed by a concave mirror when the object is placed between
 (a) infinity and center of curvature
 (b) center of curvature and focus
 (c) focus and the pole
 (d) All of the above
53. Which of the following are used in a Kaleidoscope
 (a) plane mirrors (b) concave
 (c) convex mirrors (d) All of the above
54. When a convex lens made up of glass is immersed in water, its focal length
 (a) decreases (b) does not change
 (c) increases (d) None of the above
55. Find out the correct option from the following.
 (A) The magnification is positive for all virtual images and is negative for all real images.
 (B) The magnification of concave lens and convex mirror is always positive whereas the magnification of convex lens and concave mirror can be positive or negative depending on the position of the object before the lens.
 (a) Only A is true
 (b) Only B is true.
 (c) Both A and B are true
 (d) Both A and B are false
56. A person standing at some distance from a mirror finds his image erect, virtual and of the same size. Then the mirror is possibly
 (a) plane mirror
 (b) concave mirror
 (c) plane or concave mirror
 (d) plane or concave or convex mirror
57. Refraction of light from air to glass and from air to water are shown in figure (i) and (ii) below. The value of the angle in the case of refraction as shown in figure (iii) will be :
-
- (i)
- (ii)
- (iii)
- (a) 30° (b) 35°
 (c) 60° (d) none of the above
58. The focal length of a plane mirror is
 (a) positive (b) negative
 (c) zero (d) infinity
59. Rays from the sun converge at a point 15 cm in front of a concave mirror. Where should an object be placed so that size of its image is equal to the size of the object?
 (a) 15 cm in front of the mirror
 (b) 30 cm in front of the mirror
 (c) between 15 cm and 30 cm in front of the mirror
 (d) more than 30 cm in front of the mirror.
60. A convex mirror is used
 (a) by a dentist
 (b) for shaving
 (c) as a rear view mirror in vehicles
 (d) as a light reflector for obtaining a parallel beam of light.
61. In case of a concave mirror, when the object is situated at the principal focus, the image formed is
 (a) real and inverted (b) of infinite size
 (c) lies at infinity (d) All of these

Light-Reflection and Refraction

62. For an object at infinity, a concave mirror produces an image at its focus which is
 (a) enlarged (b) virtual
 (c) erect (d) real and point sized
63. An inverted image can be seen in a convex mirror,
 (a) under no circumstances
 (b) when the object is very far from the mirror
 (c) when the object is at a distance equal to the radius of curvature of the mirror
 (d) when the distance of the object from the mirror is equal to the focal length of the mirror
64. In order to get a diminished virtual image, the object can be placed anywhere in front of a
 (a) concave mirror (b) plane mirror
 (c) convex mirror (d) none of these
65. A full length image of a distant tall building can definitely be seen by using
 (a) a concave mirror
 (b) a convex mirror
 (c) a plane mirror
 (d) both concave as well as plane mirror
66. The concave mirrors are used in
 (a) reflecting telescopes (b) magic- lanterns
 (c) cinema projectors (d) All of these
67. Which of the following statements is true?
 (a) A convex lens has 4 dioptre power having a focal length 0.25 m
 (b) A convex lens has -4 dioptre power having a focal length 0.25 m
 (c) A concave lens has 4 dipotre power having a focal length 0.25 m
 (d) A concave lens has -4 dioptre power having a focal length 0.25 m
68. A virtual, erect and magnified image of an object is to be produced with a concave mirror of focal length 12 cm. Which of the following object distance should be chosen for this purpose?
 (a) 10 cm (b) 14 cm
 (c) 18 cm (d) 24 cm
69. A 10 mm long awlpin is placed vertically in front of a concave mirror. A 5 mm long image of the awl pin is formed at 30 cm in front of the mirror. The focal length of this mirror is
 (a) -30 cm (b) -20 cm
 (c) -40 cm (d) -60 cm
70. The linear magnification for a mirror is the ratio of the size of the image to the size of the object, and is denoted by m . Then, m is equal to (symbols have their usual meanings):
 (a) $\frac{f}{f-u}$ (b) $\frac{f-u}{f}$
 (c) $\frac{f}{f+v}$ (d) $\frac{f+v}{f}$
71. In case of a real and inverted image, the magnification of a mirror is
 (a) positive (b) negative
 (c) zero (d) infinity
72. Magnification produced by a rear view mirror fitted in vehicles
 (a) is less than one
 (b) is more than one
 (c) is equal to one
 (d) can be more than or less than one depending upon the position of the object in front of it.
73. The ratio of the sine of angle of incidence to the sine of angle of refraction is called
 (a) refractive index
 (b) optical density
 (c) relative density
 (d) none of these
74. When an objects is placed between two mirrors placed inclined to each at an angle 45° Number of images formed are
 (a) 3 (b) 5
 (c) 7 (d) None of these
75. Foam of soap always appears white as
 (a) it contains large hydrocarbon chains.
 (b) it absorbs red portion of the visible light
 (c) it reflects light of all wavelengths.
 (d) it has one hydrophobic end, which is insoluble in water.
76. Two lenses of focal length f_1 and f_2 are kept in contact coaxially. The power of the combination will be
 (a) $\frac{f_1 f_2}{f_1 + f_2}$ (b) $\frac{f_1 + f_2}{f_1 f_2}$
 (c) $\frac{f_1 f_2}{f_1 - f_2}$ (d) $f_1 + f_2$

77. A mirror is placed at an angle of 30° with respect to Y -axis (see figure). A light ray travelling in the negative y -direction strikes the mirror. The direction of the reflected ray is given by the vector

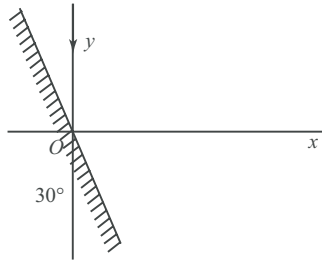

- (a) \hat{i} (b) $\hat{i} - \sqrt{3}\hat{j}$
 (c) $\sqrt{3}\hat{i} - \hat{j}$ (d) $\hat{i} - 2\hat{j}$

78. A ray of light originates from inside a glass slab and is incident on its inner surface at an angle θ as shown below.

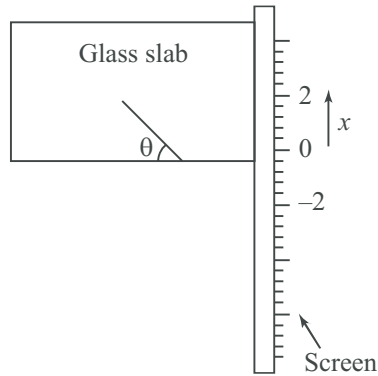

In this experiment, the location x of the spot where the ray hits the screen is recorded. Which of the following correctly shows the plot of variation of x with the angle θ ?

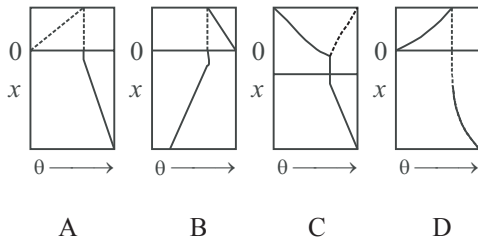

- (a) A (b) B (c) C (d) D

79. Two convex lenses A and B each of focal length 30 cm are separated by 30 cm, as shown in the figure. An object O is placed at a distance of 40 cm to the left of lens A.

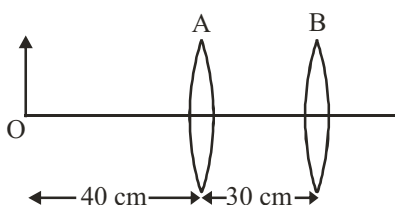

What is the distance of the final image formed by this lens system?

- (a) 120 cm to right of lens A
 (b) 90 cm to right of lens A
 (c) 22.5 cm to right of lens B
 (d) 45 cm to right of lens B
80. Two plane mirrors are kept on a horizontal table making an angle θ with each other as shown schematically in the figure. The angle θ is such that any ray of light reflected after striking both the mirrors returns parallel to its incident path. For this to happen, the value of θ should be

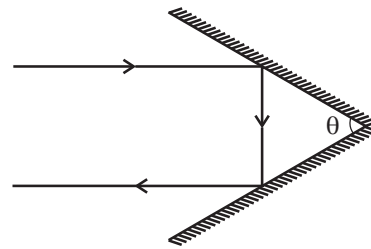

- (a) 30° (b) 45°
 (c) 60° (d) 90°
81. An object is placed at a distance of 40 cm from a concave mirror of focal length 15 cm. If the object is displaced through a distance of 20 cm towards the mirror, the displacement of the image will be
- (a) 30 cm away from the mirror
 (b) 36 cm away from the mirror
 (c) 36 cm towards the mirror
 (d) 30 cm towards the mirror
82. A pin AB of length 2 cm is kept on the axis of a convex lens between 18 cm and 20 cm as shown in figure. Focal length of convex lens is 10 cm. Find magnification produced for the image of the pin.

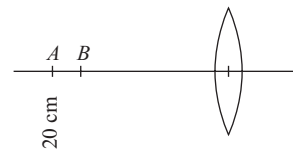

- (a) 0.83 (b) 1.00
 (c) 1.25 (d) 6.78
83. A concave mirror for face viewing has focal length of 0.4 m. The distance at which you hold the mirror from your face in order to see your image upright with a magnification of 5 is:
- (a) 0.24 m (b) 1.60 m
 (c) 0.32 m (d) 0.16 m

Light-Reflection and Refraction

84. A convex lens of focal length 20 cm is cut into two halves. Each of which is placed 0.5 mm and a point object placed at a distance of 30 cm from the lens as shown.

Then the image is at

- (a) 60 cm
(b) 30 cm
(c) 70 cm
(d) 50 cm

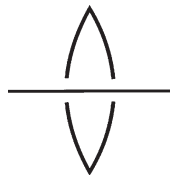

85. Focal length of a lens is 25 cm. In diopetre, power of lens will be
(a) 0.04 (b) 0.4
(c) 4 (d) 2.5
86. When viewed vertically a fish appears to be 4 meter below the surface of the lake. If the index of refraction of water is 1.33, then the true depth of the fish is
(a) 5.32 metres (b) 3.32 metres
(c) 4.32 metres (d) 6.32 metres
87. Two thin lenses of focal lengths f_1 and f_2 are placed in contact with each other such that the combination behaves as a glass slab. Then how are f_1 and f_2 related to each other?

- (a) $f_1 = \frac{1}{f_2}$ (b) $f_2 = -f_1$
(c) $f_1 = f_2$ (d) $f_1 = \sqrt{f_2}$

88. A convex lens of focal length 25 cm receives light from the sun. A diverging lens of focal length -12 cm is placed 37 cm to the right of the converging lens. Where is the final image located relative to the diverging lens?
(a) 6 cm to the left (b) 25 cm to the left
(c) At infinity (d) 12 cm to the right

89. A camera lens focuses light from a 12.0 m tall building located 35.0 m away on film 50.0 mm behind the lens.

How tall is the image of the building on the film?

- (a) 17.1 mm (b) 7.00 mm
(c) 2.50 cm (d) 1.25 mm

90. A hollow lens is made of thin glass and in the shape of a double concave lens. It can be filled with air, water of refractive index 1.33 or CS_2 of refractive index 1.6. It will act as a diverging lens, if it is

- (a) filled with air and immersed in water
(b) filled with water and immersed in CS_2
(c) filled with air and immersed in CS_2
(d) filled with CS_2 and immersed in water

91. A diverging lens with magnitude of focal length 25 cm is placed at a distance of 15 cm from a converging lens of magnitude of focal length 20 cm. A beam of parallel light falls on the diverging lens. The final image formed is :

- (a) real and at a distance of 40 cm from the divergent lens
(b) real and at a distance of 6 cm from the convergent lens
(c) real and at a distance of 40 cm from convergent lens
(d) virtual and at a distance of 40 cm from convergent lens.

92. A beam of light from a source L is incident normally on a plane mirror fixed at a certain distance x from the source. The beam is reflected back as a spot on a scale placed just above the source L . When the mirror is rotated through a small angle θ , the spot of the light is found to move through a distance y on the scale. The angle θ is given by

- (a) $\frac{y}{x}$ (b) $\frac{x}{2y}$
(c) $\frac{x}{y}$ (d) $\frac{y}{2x}$

93. A glass beaker is filled with water up to 5 cm. It is kept on top of a 2 cm thick glass slab. When a coin at the bottom of the glass slab is viewed at the normal incidence from above the beaker, its apparent depth from the water surface is d cm. Value of d is close to (the refractive indices of water and glass are 1.33 and 1.5, respectively)

- (a) 2.5 cm (b) 5.1 cm
(c) 3.7 cm (d) 6.0 cm

94. A convex lens is put 10 cm from a light source and it makes a sharp image on a screen, kept 10 cm from the lens. Now a glass block (refractive index 1.5) of 1.5 cm thickness is placed in contact with the light source. To get the sharp image again, the screen is shifted by a distance d . Then d is:

- (a) 1.1 cm away from the lens
(b) 0
(c) 0.55 cm towards the lens
(d) 0.55 cm away from the lens

Case/Passage Based Questions

DIRECTIONS : Study the given case/passage and answer the following questions.

Case/Passage - 1

A 5.0 cm tall object is placed perpendicular to the principal axis of a convex lens of focal length 20 cm. The distance of the object from the lens is 30 cm.

95. What is the distance of image from the pole of lens?
 (a) $v = 60$ cm (b) $v = -60$ cm
 (c) $v = 30$ cm (d) $v = -30$ cm
96. What is the power of the used lens?
 (a) $+5$ D (b) -5 D
 (c) $+0.5$ D (d) -0.5 D

Case/Passage - 2

Light travels through a vacuum at a speed $c = 3 \times 10^8$ m/s. It can also travel through many materials, such as air, water and glass. Atoms in the material absorb, reemit and scatter the light, however. Therefore, light travels through the material at a speed that is less than c , the actual speed depending on the nature of the material. To describe the extent to which the speed of light in a material medium differs from that in a vacuum, we use a parameter called the index of refraction (or refractive index).

97. Figure shows a ray of light as it travels from medium A to

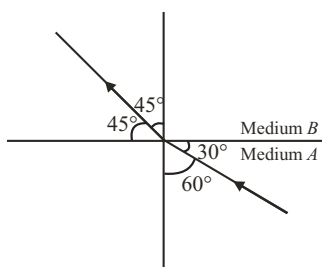

medium B . Refractive index of the medium B relative to medium A is

- (a) $\frac{\sqrt{3}}{2}$ (b) $\frac{\sqrt{2}}{\sqrt{3}}$
 (c) $\frac{1}{\sqrt{2}}$ (d) $\sqrt{2}$
98. A light ray enters from medium A to medium B as shown

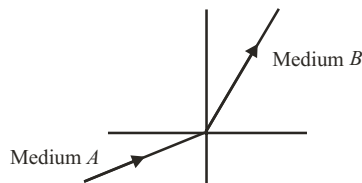

in the figure. The refractive index of medium B relative to A will be

- (a) greater than unity (b) less than unity
 (c) equal to unity (d) zero
99. The path of a ray of light coming from air passing through a rectangular glass slab traced by four students shown as A , B , C and D in the figure. Which one of them is correct?

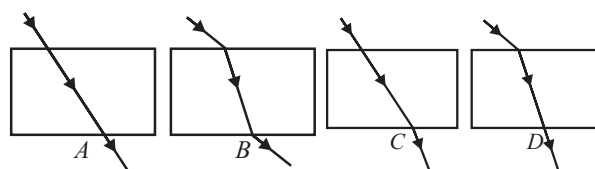

- (a) A (b) B
 (c) C (d) D
100. You are given water, mustard oil, glycerine and kerosene. In which of these media, a ray of light incident obliquely at same angle would bend the most?
 (a) Kerosene (b) Water
 (c) Mustard oil (d) Glycerine
101. A ray of light is incident in medium 1 on a surface that separates medium 1 from medium 2. Let v_1 and v_2 represent the velocity of light in medium 1 and medium 2 respectively. Also let n_{12} and n_{21} represent the refractive index of medium 1 with respect to medium 2 and refractive index of medium 2 with respect to medium 1, respectively. If i and r denote the angle of incidence and angle of refraction, then-

- (a) $\frac{\sin i}{\sin r} = n_{21} \frac{v_1}{v_2}$ (b) $\frac{\sin i}{\sin r} = n_{21} \frac{v_2}{v_1}$
 (c) $\frac{\sin i}{\sin r} = n_{12} \frac{v_1}{v_2}$ (d) $\frac{\sin i}{\sin r} = n_{12} \frac{v_2}{v_1}$

Case/Passage - 3

Inside a substance such as glass or water, light travels more slowly than it does in a vacuum. If c denotes the speed of light in a vacuum and v denotes its speed through some other substance, then $v = c/n$ where n is a constant called the index of refraction.

To good approximation, a substance's index of refraction does not depend on the wavelength of light. For instance, when red and blue light waves enter water, they both slow down by about the same amount. More precise measurements, however, reveal that n varies with wavelength. Table presents some indices of refraction of Custon glass, for different wavelengths of visible light. A nanometer (nm) is 10^{-9} meters. In a vacuum, light travels as $c = 3.0 \times 10^8$ m/s

Table : Indices of refraction of Custon glass

Approximately colour	Wavelength in vacuum (nm)	"Indices n"
yellow	580	1.5
yellow orange	600	1.498
orange	620	1.496
orange red	640	1.494

Light-Reflection and Refraction

102. Inside Custon glass
- Orange light travels faster than yellow light
 - Yellow light travels faster than orange light
 - Orange and Yellow light travels equally fast
 - We cannot determine which color of light travels faster
103. For blue-green of wavelength 520 nm, the index of refraction of Custon glass is probably closest to
- 1.49
 - 1.50
 - 1.51
 - 1.52
104. Which of the following phenomena happens because n varies with wavelength
- A lens focuses light
 - A prism breaks sunlight into different colors
 - Total internal reflections ensures that light travels down a fiber optic cable
 - Light rays entering a pond change direction at the pond's surface

Assertion & Reason

DIRECTIONS : Each of these questions contains an assertion followed by reason. Read them carefully and answer the question on the basis of following options. You have to select the one that best describes the two statements.

- If both **Assertion** and **Reason** are **correct** and Reason is the **correct explanation** of Assertion.
 - If both **Assertion** and **Reason** are correct, but Reason is **not the correct explanation** of Assertion.
 - If **Assertion** is **correct** but **Reason** is **incorrect**.
 - If **Assertion** is **incorrect** but **Reason** is **correct**.
105. **Assertion :** The diameter of convex lens required to form full image of an object is half the height of the object.
- Reason :** The smaller diameter lens will give full image of lower intensity.
106. **Assertion :** The image of a point object situated at the centre of hemispherical lens is also at the centre.
- Reason :** For hemisphere Snell's law is not valid.
107. **Assertion :** A point object is placed at a distance of 26 cm from a convex mirror of focal length 26 cm. The image will not form at infinity.
- Reason :** For above given system the equation $\frac{1}{u} + \frac{1}{v} = \frac{1}{f}$ gives $v = \infty$.
108. **Assertion :** When a concave mirror is held under water, its focal length will increase.
- Reason :** The focal length of a concave mirror is independent of the medium in which it is placed.
109. **Assertion :** A convex mirror is used as a driver's mirror.
- Reason :** Because convex mirror's field of view is large and images formed are virtual, erect and diminished.
110. **Assertion :** When the object moves with a velocity \vec{v} , its image in the plane mirror moves with a velocity of $-2\vec{v}$ with respect to the object.
- Reason :** The minimum height of the mirror to be required to see the full image of man of height h is $\frac{h}{2}$.
111. **Assertion :** As the temperature of a medium increases the refractive index decreases.
- Reason :** When a ray travels from vacuum to a medium, then μ is known as absolute refractive index of the medium. ($\mu_{\text{vacuum}} = 1$).
112. **Assertion :** If a spherical mirror is dipped in water, its focal length remains unchanged.
- Reason :** A laser light is focused by a converging lens. There will be a significant chromatic aberration.
113. **Assertion :** A virtual image cannot be projected on screen.
- Reason :** Virtual images are formed by actual meeting of rays of light after reflection or refraction.
114. **Assertion :** Red light travels faster in glass than green light.
- Reason :** The refractive index of glass is less for red light than for green light.
115. **Assertion :** As light travels from one medium to another, the frequency of light does not change.
- Reason :** Because frequency is the characteristic of source.
116. **Assertion :** Light rays retrace their path when their direction is reversed (Law of reversibility of light rays)
- Reason :** For the refraction of light, water is denser than air, but for the refraction of sound, water is rarer than air.
117. **Assertion :** The mirrors used in search lights are parabolic and not concave spherical.
- Reason :** Silvered plano convex lens is used in search light.

Match the Following

DIRECTIONS : Each question contains statements given in two columns which have to be matched. Statements (A, B, C, D) in column I have to be matched with statements (p, q, r, s) in column II.

118. Match the following :

Column I

- (A) Power of convex mirror
(B) Power of concave mirror
(C) Power of plane mirror
(D) Power of convex lens

Column II

- (p) Positive power
(q) Negative power
(r) Zero power
(s) Infinite power

119. The graphs given apply to convex lens of focal length f , producing a real image at a distance v from the optical centre when self luminous object is at distance u from the optical centre. The magnitude of magnification is m . Identify the following graphs with the first named quantity being plotted along y-axis.

Column I

- (A) v against u
(B) $\frac{1}{v}$ against $\frac{1}{u}$
(C) m against v
(D) $(m + 1)$ against $\frac{v}{f}$

Column II

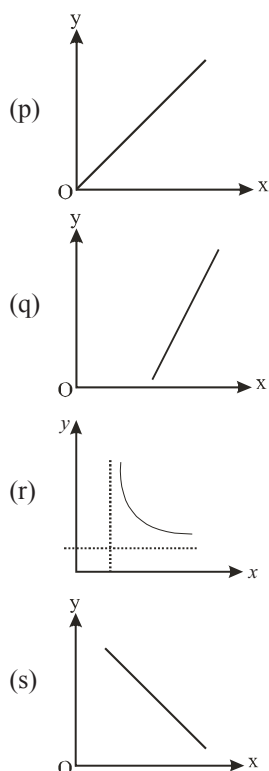

Fill in the Blanks

DIRECTIONS : Complete the following statements with an appropriate word / term to be filled in the blank space(s).

120. The power of a convex lens is and that of a concave lens is

121. Light seems to travel in

122. A light ray travelling obliquely from a denser medium to a rarer medium bends the normal. A light ray bends the normal when it travels obliquely from a rarer to a denser medium.

123. In case of a rectangular glass slab, the refraction takes place at both interface and interface. The emergent ray is to the direction of incident ray.

124. Power of a lens is the reciprocal of its

125. The SI unit of power of a lens is

126. The angle of incidence is to the angle of reflection.

127. The reflecting surface of a spherical mirror may be curved or

128. The inner surface of the spoon can be approximated to a mirror.

129. The centre of the reflecting surface of a spherical mirror is a point called the

130. The centre of curvature of a concave mirror lies in of it.

131. Line passing through the pole and the centre of curvature of a spherical mirror is called the

132. A ray parallel to the principal axis, after reflection, will pass through the

133. The dentists use mirrors to see large images of the teeth of patients.

134. A transparent material bound by two surfaces, of which one or both surfaces are spherical, forms a

135. The degree of of light rays achieved by a lens is expressed in terms of its power.

136. An object is placed in front of a spherical mirror. The image is found to be virtual for all positions of the object. The spherical mirror is

137. Two immiscible transparent liquids A and B have 1.2 and 1.5 as their refractive indices (with respect to air). The refractive index of B with respect to A is

True / False

DIRECTIONS : Read the following statements and write your answer as true or false.

Light-Reflection and Refraction

138. The reflecting surfaces, of all types, obey the laws of reflection.
139. Light travels in vacuum with an enormous speed of $3 \times 10^8 \text{ ms}^{-1}$.
140. The speed of light is different in different media.
141. The refractive index of a transparent medium is the ratio of the speed of light in vacuum to that in the medium.
142. The incident ray, the normal to the mirror at the point of incidence and the reflected ray, all lie in the same plane.
143. Image formed by a plane mirror is always virtual and erect.
144. The principal focus of a spherical mirror lies midway between the pole and centre of curvature.
145. Convex mirrors enable the driver to view much larger area than would be possible with a plane mirror.
146. A concave lens will always give a virtual, erect and diminished image.
147. A ray of light passing through the optical centre of a lens will emerge without any deviation.
148. The image in a plane mirror lies as far behind the mirror.
149. An object is placed in front of a mirror and an image of it is formed at the object itself. The mirror mentioned in question is a convex mirror.
150. A concave mirror can produce both real and virtual images.
151. Light travels faster in glass than in air.
152. The laws of reflection are valid for plane mirrors and not for spherical mirrors.
153. The mirror formula is valid only if the aperture of the mirror is small.
154. When a ray of light travels from air to water, its speeds up.
155. A lens that is thicker at the middle than at the edges is a diverging lens.

ANSWER KEY & SOLUTIONS

1. (b) In plane mirror, object distance = image distance

∴ Distance between object and image

$$= 0.5 + 0.5 = 1 \text{ m}$$

2. (a) $n = \frac{360^\circ}{90^\circ} = 4$

so numbe of images is $(n - 1) \Rightarrow (4 - 1) = 3$

3. (b) Concave mirror is used as a shaving mirror

4. (c) For all spherical mirrors $f = R/2$

5. (c) given, $m = \frac{\text{Image height}}{\text{object height}} > 1$

\Rightarrow Image height $>$ Object height

6. (b) Convex mirror always form virtual and erect image.

7. (b) 8. (c)

9. (a) Power = $\frac{1}{\text{focal length}}$

10. (a) Magnification, $m = \frac{\text{Image height}}{\text{Object height}}$

11. (b) Diminished, erect image is formed by convex mirror.

12. (b) 13. (b) 14. (a) 15. (c)

16. (d) For a spherical lens $\frac{1}{v} - \frac{1}{u} = \frac{1}{f}$

For convex lens. $u = -f/2$ and f is +ve

$$\therefore \frac{1}{v} = \frac{1}{f} + \frac{1}{u} + \frac{1}{f} = +\frac{1}{f} - \frac{2}{f} \therefore v = -f$$

17. (d) 18. (c) 19. (a) 20. (c) 21. (a)

22. (a) 23. (c) 24. (b) 25. (c) 26. (b)

27. (c) 28. (d) 29. (d) 30. (d) 31. (d)

32. (d) 33. (b) 34. (b) 35. (a) 36. (a)

37. (b) 38. (d) 39. (a) 40. (a) 41. (b)

42. (c) 43. (b) 44. (c) 45. (b) 46. (c)

47. (c) 48. (c) 49. (b) 50. (b) 51. (d)

52. (c) 53. (a) 54. (c) 55. (c) 56. (a)

57. (b) ${}^a\mu_g = \frac{\sin 60^\circ}{\sin 35^\circ}$ and ${}^a\mu_w = \frac{\sin 60^\circ}{\sin 41^\circ}$

$$\therefore {}^a\mu_g = \frac{{}^a\mu_w}{\sin \theta} = \frac{\sin 41^\circ}{\sin \theta}$$

$$\text{or } \left(\frac{\sin 60^\circ}{\sin 35^\circ} / \frac{\sin 60^\circ}{\sin 41^\circ} \right) = \frac{\sin 41^\circ}{\sin \theta}$$

$$\therefore \theta = 35^\circ$$

58. (d) 59. (b) 60. (c) 61. (d) 62. (d)

63. (a) 64. (c) 65. (b) 66. (d) 67. (a)

68. (a) 69. (b) 70. (a) 71. (b) 72. (a)

73. (a)

74. (c) Number of images formed = $\frac{360^\circ}{\theta} - 1 = 7$.

75. (c)

76. (b) $P = P_1 + P_2 \Rightarrow P = \frac{1}{f_1} + \frac{1}{f_2} \Rightarrow P = \frac{f_1 + f_2}{f_1 f_2}$

77. (c) According to laws of reflection,

angle of incidence = angle of reflection

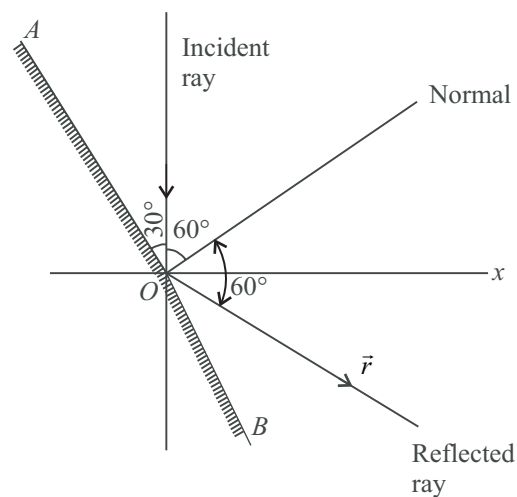

- ∴ if a vector \vec{r} is along the reflected ray, then

$$\vec{r} = \cos 30^\circ \hat{i} - \sin 30^\circ \hat{j}$$

$$\vec{r} = \frac{\sqrt{3}}{2} \hat{i} - \frac{1}{2} \hat{j}$$

$$\vec{r} = \sqrt{3} \hat{i} - \hat{j}$$

Hence, the direction of the reflected ray vector is .

$$\sqrt{3} \hat{i} - \hat{j}$$

Light-Reflection and Refraction

78. (a) Angle of incidence, $i = 90^\circ - \theta$, decreases with increase in θ upto angle of incidence $i =$ critical angle reflection takes place so x is positive and beyond the critical angle refraction takes place so x is negative.

Hence graph 'A' correctly depicts variation of x with the angle θ .

79. (c) For lens A, $\frac{1}{f} = \frac{1}{v} - \frac{1}{u}$

$$\Rightarrow \frac{1}{30} = \frac{1}{v} - \left(-\frac{1}{40}\right)$$

$$\Rightarrow \frac{1}{30} = \frac{1}{v} + \frac{1}{40}$$

$$= \frac{4-3}{120} = \frac{1}{120} \text{ or, } v = 120 \text{ cm.}$$

For lens B, $u = 90 \text{ cm}$ [$u = 120 - 30$]

$$\frac{1}{f} = \frac{1}{v} - \frac{1}{u} \Rightarrow \frac{1}{30} = \frac{1}{v} - \frac{1}{90}$$

$$\frac{1}{v} = \frac{1}{30} + \frac{1}{90} = \frac{3+1}{90}$$

$$\text{or, } v = 22.5 \text{ cm}$$

Which is positive so that it is 22.5 cm from lens B.

80. (d) Two mirrors are inclined at an angle, $\theta = ?$

According to question, emergent ray is parallel to incident ray

$$\therefore \text{ deviation angle } \delta = 180^\circ$$

$$\text{But } \delta = 360^\circ - 2\theta$$

$$\text{or, } 360^\circ - 2\theta = 180^\circ$$

$$\text{or, } 2\theta = 180^\circ$$

$$\therefore \theta = 90^\circ$$

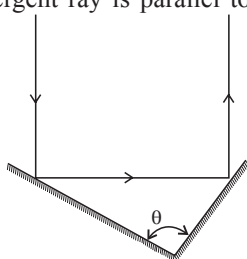

81. (b)

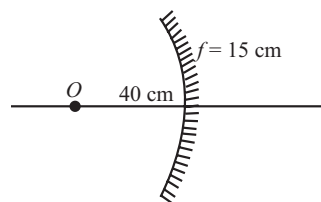

Using mirror formula, $\frac{1}{f} = \frac{1}{v_1} + \frac{1}{u}$

$$-\frac{1}{15} = \frac{1}{v_1} + \frac{1}{40} \Rightarrow \frac{1}{v_1} = \frac{1}{-15} + \frac{1}{40}$$

$$\therefore v_1 = -24 \text{ cm}$$

When object is displaced by 20 cm towards mirror

$$\text{Now, } u_2 = -20$$

$$\text{So, } \frac{1}{f} = \frac{1}{v_2} + \frac{1}{u_2}$$

$$\frac{1}{-15} = \frac{1}{v_2} - \frac{1}{20} \Rightarrow \frac{1}{v_2} = \frac{1}{20} - \frac{1}{15}$$

$$\therefore v_2 = -60 \text{ cm}$$

Therefore image shifts away from mirror by $= 60 - 24 = 36 \text{ cm}$

82. (c) For the end B, image distance of end B will be,

$$f = 10 \text{ cm}$$

$$u_B = -18 \text{ cm}$$

$$v_B = \text{image distance of end B}$$

As we know,

$$\frac{1}{f} = \frac{1}{v_B} - \frac{1}{u_B}$$

$$\frac{1}{v_B} = \frac{1}{f} + \frac{1}{u_B}$$

$$\frac{1}{v_B} = \frac{1}{10} - \frac{1}{18} = \frac{8}{180}$$

$$v_B = \frac{180}{8} \Rightarrow 22.5 \text{ cm}$$

Similarly, for the end A, image distance of end A will be,

$$f = 10 \text{ cm}$$

$$u_A = -20 \text{ cm}$$

$$v_A = \text{image distance of end A}$$

$$\frac{1}{f} = \frac{1}{v_A} - \frac{1}{u_A}$$

$$\frac{1}{v_A} = \frac{1}{f} + \frac{1}{u_A}$$

$$\frac{1}{v_A} = \frac{1}{10} - \frac{1}{20} = \frac{1}{20}$$

$$v_A = 20 \text{ cm}$$

$$\text{So, length of image } A'B' = (v_B - v_A)$$

$$= 22.5 - 20 = 2.5 \text{ cm}$$

$$\text{So magnification, } m = \frac{A'B'}{AB} \Rightarrow \frac{2.5}{2} = 1.25$$

83. (c) $+5 = -\frac{v}{u} \Rightarrow v = -5u$

$$\text{Using } \Rightarrow \frac{1}{v} + \frac{1}{u} = \frac{1}{f} \Rightarrow \frac{1}{-5u} + \frac{1}{u} = \frac{-1}{0.4}$$

$$\therefore u = -0.32 \text{ m.}$$

84. (a) Given,

Object distance, $u = 30\text{cm}$

when a lens is cut along the principle axis into two equal parts focal length remains same for each part.

\therefore Focal length, $f = 20\text{cm}$

using lens formula

$$\frac{1}{f} = \frac{1}{v} - \frac{1}{u}$$

$$\text{P } \frac{1}{v} = \frac{1}{20} - \frac{1}{30} = \frac{1}{60}$$

$$\Rightarrow v = 60\text{ cm}$$

85. (c) Focal length of a lens, $F = 25\text{ cm}$

$$f = 0.25\text{ m}$$

$$P = \frac{1}{f} = \frac{1}{0.25} = 4D$$

86. (a) 87. (b) 88. (a) 89. (a)

90. (d) Here $\mu_{\text{CS}_2} > \mu_{\text{water}} > \mu_{\text{air}}$

i.e., CS_2 is denser than water and water is denser than air.

When medium outside a lens is denser than medium of lens, then a concave lens will act like a convex lens and *vice-versa*.

Hence, lens here acts as a diverging lens when filled with CS_2 and immersed in water.

91. (c) As parallel beam incident on diverging lens will form image at focus.

$$\therefore v = -25\text{ cm}$$

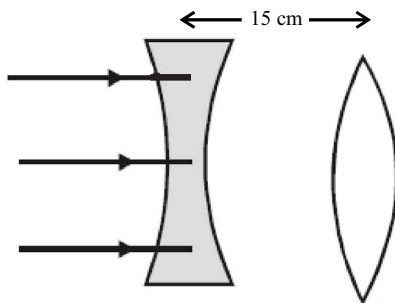

$$f = -25\text{ cm}$$

$$f = 20\text{ cm}$$

The image formed by diverging lens is used as an object for converging lens,

So for converging lens $u = -25 - 15 = -40\text{ cm}$, $f = 20\text{ cm}$

\therefore Final image formed by converging lens

$$\frac{1}{V} - \frac{1}{-40} = \frac{1}{20}$$

or, $V = 40\text{ cm}$ from converging lens real and inverted.

92. (d) When mirror is rotated by angle θ reflected ray will be rotated by 2θ .

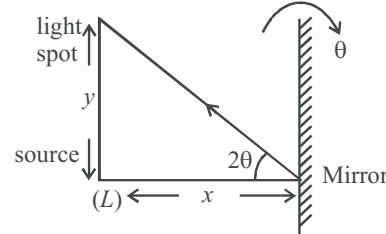

$$\frac{y}{x} = 2\theta \Rightarrow \theta = \frac{y}{2x}$$

93. (b) Given: $d_1 = 5\text{ cm}$, $\mu_1 = 1.33$

$$d_2 = 2\text{ cm}, \mu_2 = 1.5$$

d_1 and d_2 are the thickness of slabs of medium with refractive index μ_1 and μ_2 , respectively.

$$\text{using formula, } d = \frac{d_1}{\mu_1} + \frac{d_2}{\mu_2} + \dots$$

$$\text{Apparent depth, } d = \frac{5}{1.33} + \frac{2}{1.5}$$

$$= 5.088\text{ cm} = 5.1\text{ cm}$$

94. (d)

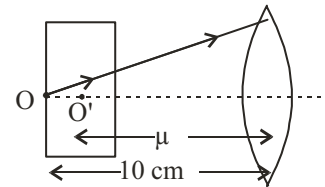

As the object and image distance is same, object is placed at $2f$. Therefore $2f = 10$

$$\text{or } f = 5\text{ cm.}$$

$$\text{Shift due to slab, } d = t \left(1 - \frac{1}{\mu} \right)$$

in the direction of incident ray

$$\Rightarrow d = 1.5 \left(1 - \frac{2}{3} \right) = 0.5\text{ cm}$$

$$\text{Now, } u = -9.5\text{ cm}$$

$$\text{Again using lens formulas } \frac{1}{v} - \frac{1}{-9.5} = \frac{1}{5}$$

$$\Rightarrow v = 10.55\text{ cm}$$

Thus, screen is shifted by a distance $d = 10.55 - 10 = 0.55\text{ cm}$ away from the lens.

Light-Reflection and Refraction

95. (a) Object size $h_0 = 5.0$ cm, $f = 20$ cm,

Object distance $u = -30$ cm

$$\text{Since, } \frac{1}{v} - \frac{1}{u} = \frac{1}{f}$$

$$\frac{1}{v} = \frac{1}{f} + \frac{1}{u}$$

$$\text{Then } \frac{1}{v} = \frac{1}{20} + \frac{1}{-30} = \frac{1}{60}$$

$$\therefore v = +60 \text{ cm}$$

Positive sign of v shows that image is formed at a distance of 60 cm from the pole to the right of the lens.

Therefore image is real and inverted.

96. (a) Power = $\frac{1}{f} = \frac{1}{0.2\text{m}} = +5\text{D}$

97. (a) From figure, angle of incidence, $i = 60^\circ$ and angle of refraction, $r = 45^\circ$

Refractive index of the medium B relative to medium A , (from Snell's law)

$$\mu_{BA} = \frac{\sin i}{\sin r} = \frac{\sin 60^\circ}{\sin 45^\circ} = \frac{\left(\frac{\sqrt{3}}{2}\right)}{\left(\frac{1}{\sqrt{2}}\right)} = \frac{\sqrt{3}}{2}$$

98. (a) Since light rays in the medium B goes towards normal (figure), so it has greater refractive index i.e., denser w.r.t. medium A . Hence, refractive index of medium B relative to medium A is greater than unity.

99. (b) In a rectangular glass slab, the emergent rays are parallel to the direction of the incident ray, as the extent of bending of the ray of light at the opposite parallel faces air-glass and glass-air interface of the rectangular glass slab is equal and opposite.

This is why the ray emerges are parallel to the incident ray.

100. (d) Among the given material kerosene refractive index, $\mu = 1.44$, water $\mu = 1.33$, mustard oil $\mu = 1.46$ and glycerine $\mu = 1.74$. Glycerine is most optically denser. Therefore, ray of light bend most in glycerine.

101. (a) $\frac{\sin i}{\sin r} = n_{21} = \frac{v_1}{v_2}$

102. (a) 103. (c) 104. (b)

105. (d) Any size of lens, can form full image, only intensity of image decreases with decrease in size.

106. (c) The rays from centre of hemisphere cut at the centre after refraction - Snell's law is valid in each case of refraction.

107. (d) 108. (d) 109. (a) 110. (b)

111. (b) 112. (c)

113. (c) Virtual image is formed when the rays of light after reflection or refraction appear to meet at a point.

114. (a) 115. (a) 116. (c) 117. (c)

118. (A) \rightarrow p; (B) \rightarrow p; (C) \rightarrow r; (D) \rightarrow p

119. (A) \rightarrow r; (B) \rightarrow p; (C) \rightarrow q; (D) \rightarrow s

120. positive, negative. 121. straight lines.

122. away from, towards 123. air-glass, glass-air, parallel

124. focal length 125. diopetre

126. equal 127. inwards, outwards.

128. concave 129. pole

130. front 131. principal axis

132. principal focus 133. concave

134. lens. 135. convergence or divergence

136. convex 137. 5/4

138. True 139. True 140. True 141. True

142. True 143. True 144. True 145. True

146. True 147. True 148. True 149. False

150. True 151. False 152. False 153. True

154. False 155. False