

## EXERCISE-01

## MCQ (SINGLE CHOICE CORRECT)

1. A body of mass  $m_1$  exerts a force on another body of mass  $m_2$ . If the magnitude of acceleration of  $m_2$  is  $a_2$ , then the magnitude of the acceleration of  $m_1$  is (considering only two bodies in space)

(A) Zero                      (B)  $\frac{m_2 a_2}{m_1}$                       (C)  $\frac{m_1 a_2}{m_2}$                       (D)  $a_2$

2. Figures I, II, III and IV depicts variation of force with time

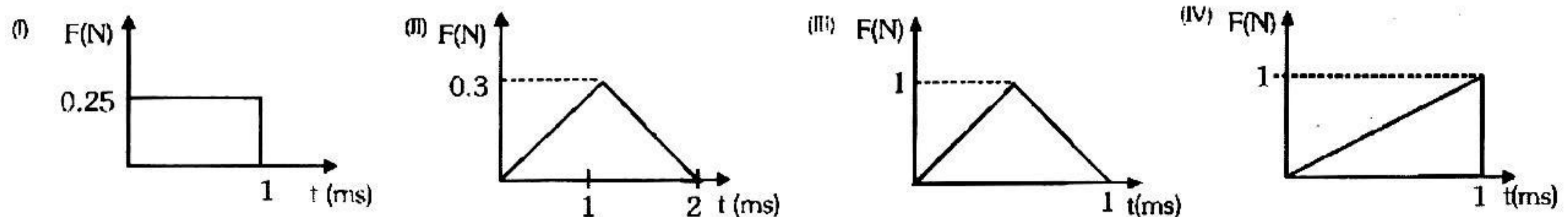

In which situation impulse will be maximum

(A) I & II                      (B) III & I                      (C) III & IV                      (D) Only IV

3. A body kept on a smooth inclined plane inclination  $1$  in  $x$  will remain stationary relative to the inclined plane if the plane is given a horizontal acceleration equal to :-

(A)  $\sqrt{x^2 - 1}g$                       (B)  $\frac{\sqrt{x^2 - 1}}{x}g$                       (C)  $\frac{gx}{\sqrt{x^2 - 1}}$                       (D)  $\frac{g}{\sqrt{x^2 - 1}}$

4. A pulley is attached to the ceiling of a lift moving upwards. Two particles are attached to the two ends of a massless string passing over the smooth pulley. The masses of the particles are in the ratio  $2 : 1$ . If the acceleration of the particles is  $g/2$  w.r.t. lift, then the acceleration of the lift will be

(A)  $g$                       (B)  $\frac{g}{2}$                       (C)  $\frac{g}{3}$                       (D)  $\frac{g}{4}$

5. A block is kept on a smooth inclined plane of angle of inclination  $30^\circ$  that moves with a constant acceleration so that the block does not slide relative to the inclined plane. Let  $F_1$  be the contact force between the block and the plane. Now the inclined plane stops and let  $F_2$  be the contact force between the two in this case. Then  $F_1/F_2$  is

(A) 1                      (B)  $\frac{4}{3}$                       (C) 2                      (D)  $\frac{3}{2}$

6. A cylinder rests in a supporting carriage as shown. The side AB of carriage makes an angle  $30^\circ$  with the horizontal and side BC is vertical. The carriage lies on a fixed horizontal surface and is being pulled towards left with an horizontal acceleration 'a'. The magnitude of normal reactions exerted by sides AB and BC of carriage on the cylinder be  $N_{AB}$  and  $N_{BC}$  respectively. Neglect friction everywhere. Then as the magnitude of acceleration 'a' of the carriage is increased, pick up the correct statement:

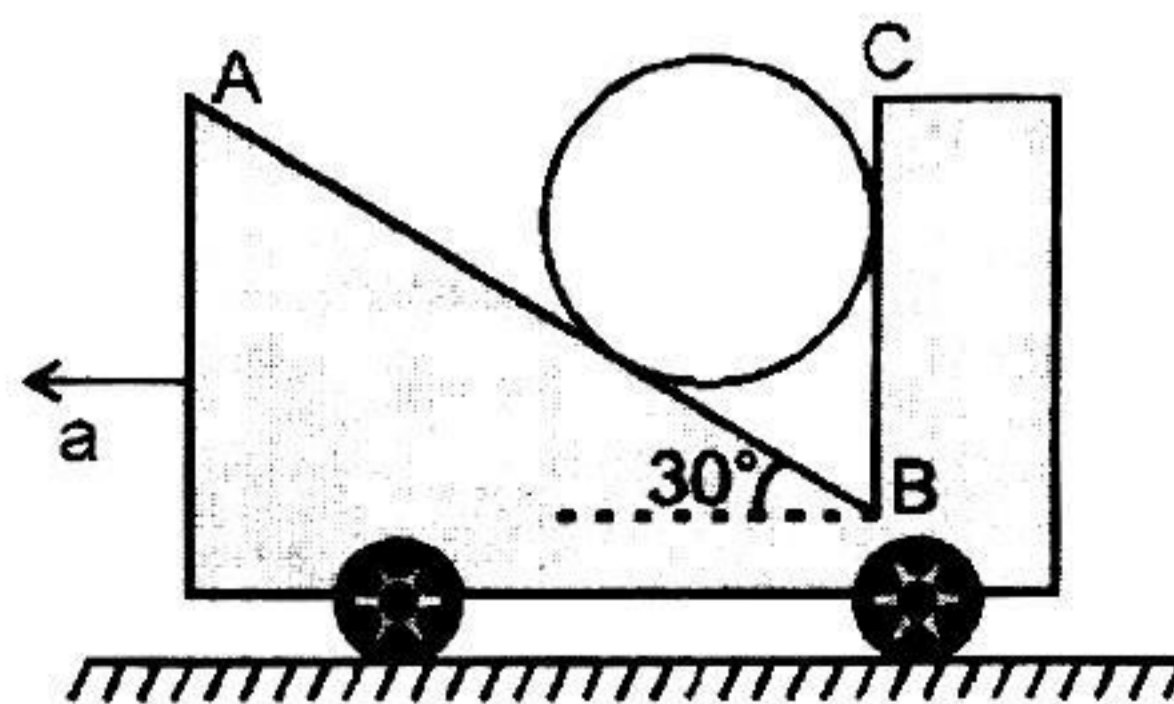

(A)  $N_{AB}$  increases and  $N_{BC}$  decreases.                      (B) Both  $N_{AB}$  and  $N_{BC}$  increase.  
 (C)  $N_{AB}$  remains constant and  $N_{BC}$  increases.                      (D)  $N_{AB}$  increases and  $N_{BC}$  remains constant.

7. Two blocks A and B of masses  $m$  &  $2m$  respectively are held at rest such that the spring is in natural length. What is the acceleration of both the blocks just after release?

(A)  $g \downarrow, g \downarrow$

(B)  $\frac{g}{3} \downarrow, \frac{g}{3} \uparrow$

(C)  $0, 0$

(D)  $g \downarrow, 0$

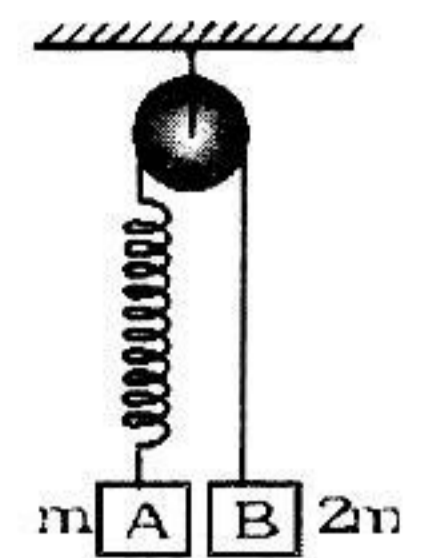

8. For the system (in equilibrium) shown in the figure, the acceleration of the mass  $m_4$  immediately after the lower thread  $x$  is cut will be, (assume that the threads are weightless and inextensible, the spring are weightless, the mass of pulley is negligible and there is no friction)

(A)  $0$

(B)  $\left(\frac{m_1 + m_2 - m_3}{m_4}\right)g$

(C)  $\left(\frac{m_1 + m_2 - m_3 - m_4}{m_4}\right)g$

(D)  $\frac{g}{4}$

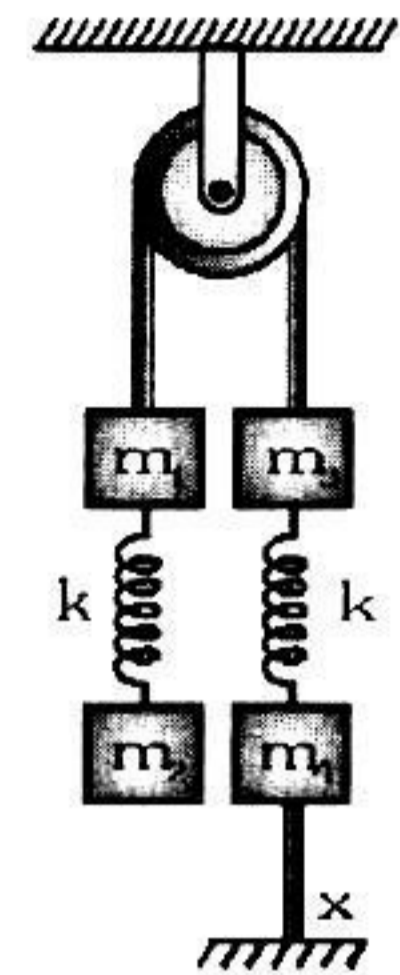

9. In the arrangement shown in figure, pulley is smooth and massless and all the strings are light. Let  $F_1$  be the force exerted on the pulley by the string in case (i) and  $F_2$  the force in case (ii). Then

(A)  $F_1 > F_2$

(B)  $F_1 < F_2$

(C)  $F_1 = F_2$

(D)  $F_1 = 2F_2$

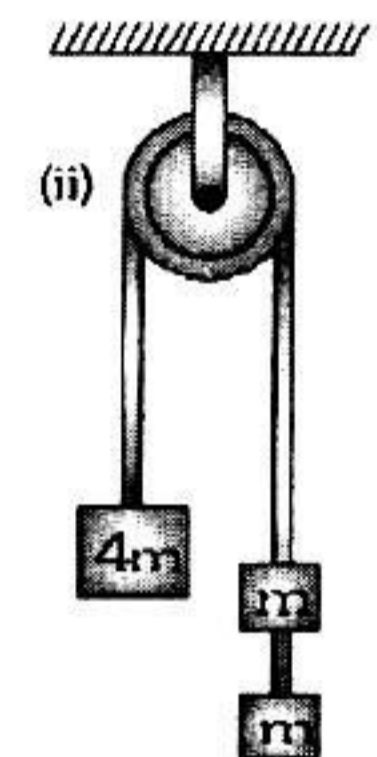
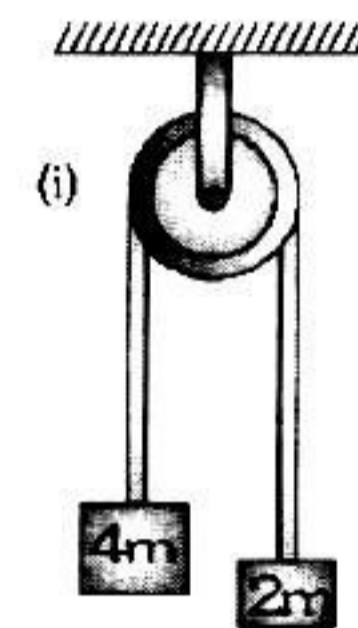

10. In figure shown, both blocks are released from rest. The time to cross each other is

(A) 2 second

(B) 3 second

(C) 1 second

(D) 4 second

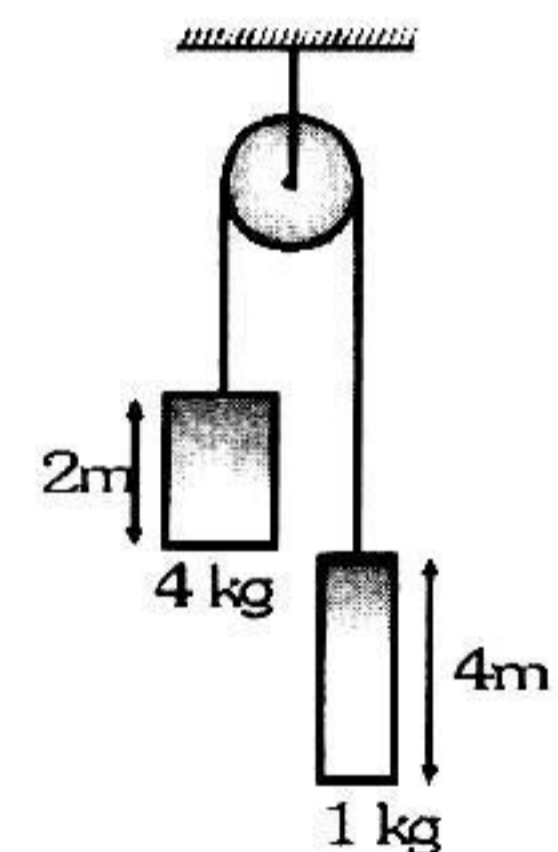

11. If the acceleration of the elevator  $a_0 > g$ , then

(A) the acceleration of the masses will be  $a_0$

(B) the acceleration of the masses will be  $(a_0 - g)$

(C) the tension in the string will be  $\frac{mM}{M + m}(g - a_0)$

(D) tension in the string will be zero.

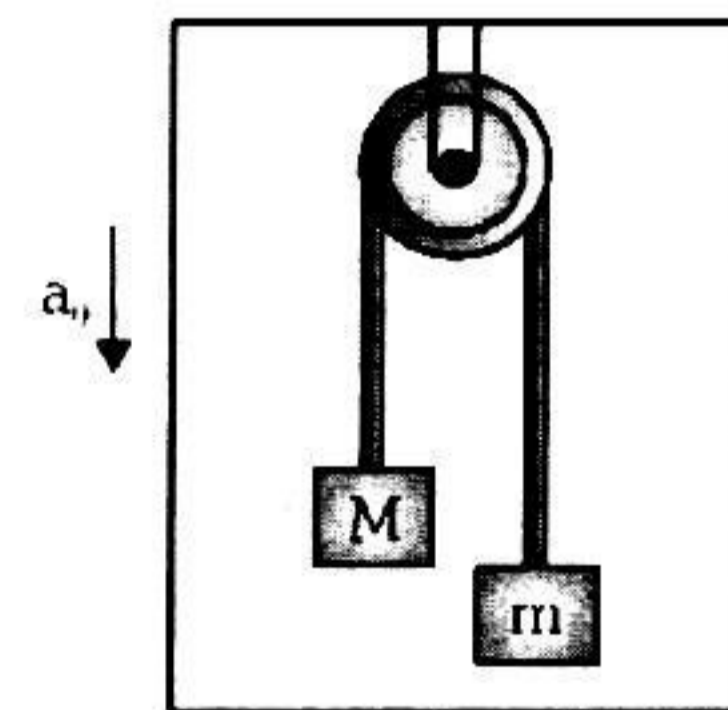

12. If masses are released from the position shown in figure then time elapsed before mass  $m_1$  collides with the floor will be :

(A)  $\sqrt{\frac{2m_1gd}{m_1 + m_2}}$

(B)  $\sqrt{\frac{2(m_1 + m_2)d}{(m_1 - m_2)g}}$

(C)  $\sqrt{\frac{2(m_1 - m_2)d}{(m_1 + m_2)g}}$

(D) None of these

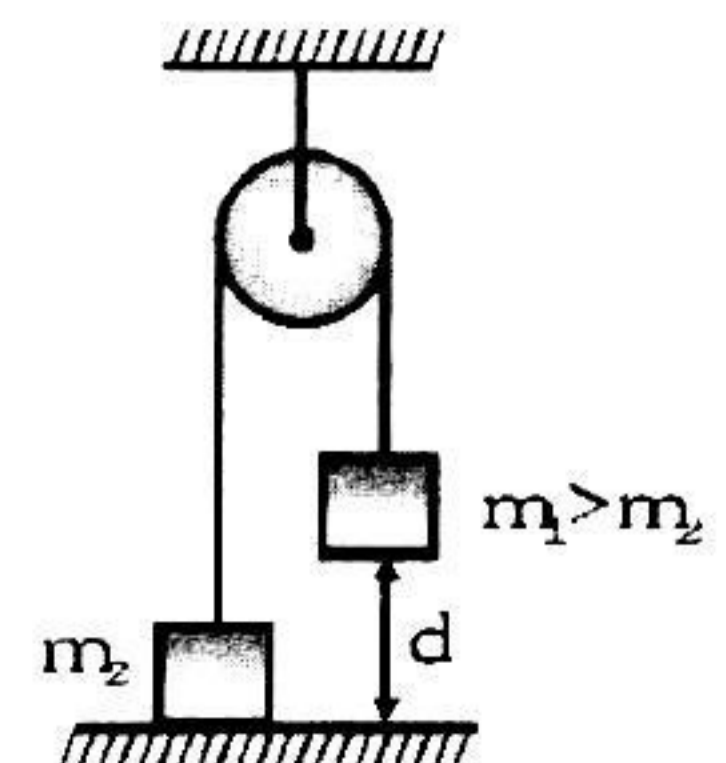

13. In the arrangement shown in figure  $m_1 = 1\text{kg}$ ,  $m_2 = 2\text{kg}$ . Pulleys are massless and strings are light. For what value of  $M$  the mass  $m_1$  moves with constant velocity (Neglect friction)

- (A) 6 kg (B) 4 kg  
(C) 8 kg (D) 10 kg

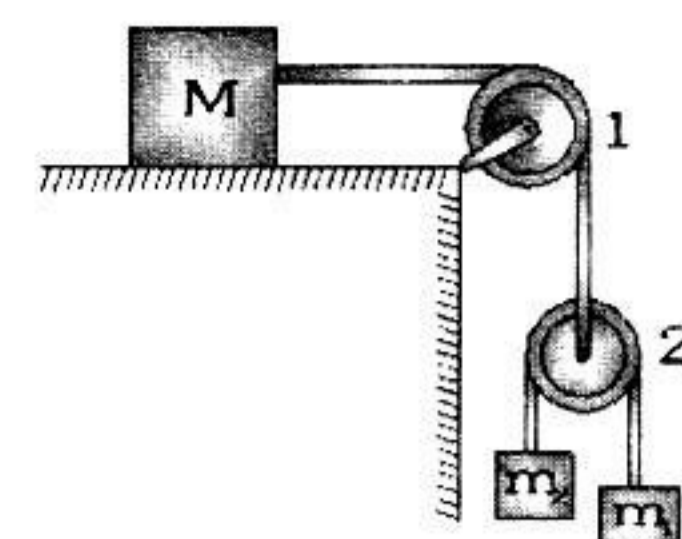

14. A trolley is being pulled up an incline plane by a man sitting on it (as shown in figure). He applies a force of 250 N. If the combined mass of the man and trolley is 100 kg, and both move together, the acceleration of the trolley will be [ $\sin 15^\circ = 0.26$ ]

- (A)  $2.4\text{ m/s}^2$  (B)  $9.4\text{ m/s}^2$   
(C)  $6.9\text{ m/s}^2$  (D)  $4.9\text{ m/s}^2$

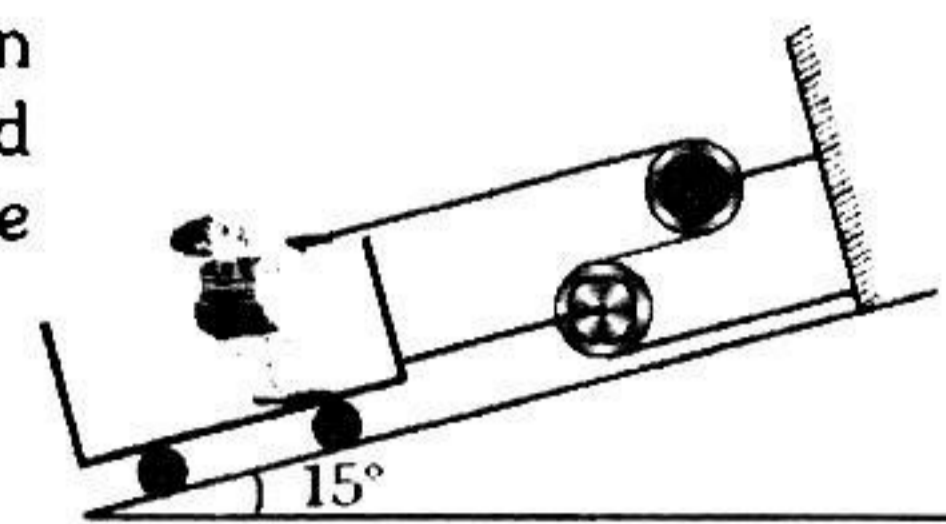

15. A man thinks about 4 arrangements as shown to raise two small bricks each having mass  $m$ . Which of the arrangement would take minimum time?

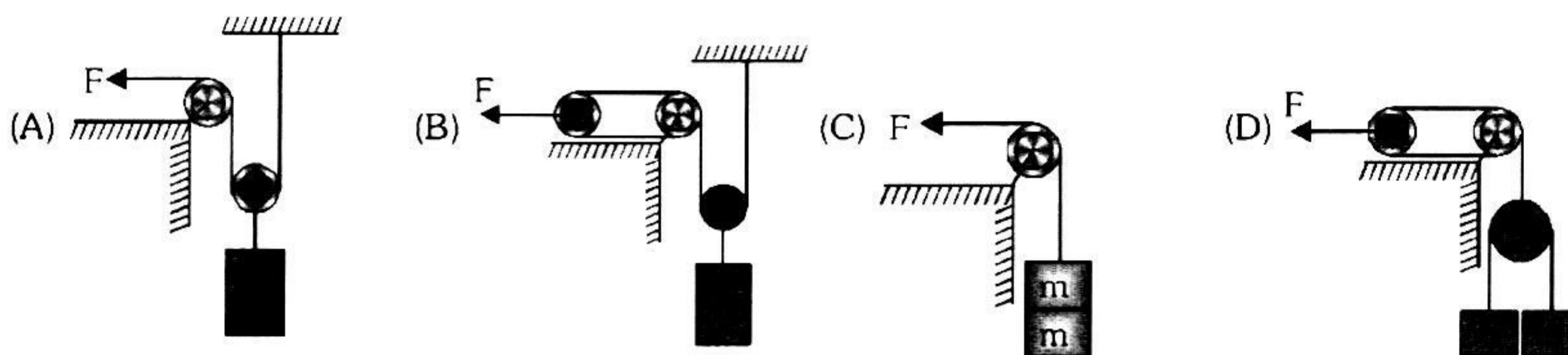

16. In the arrangement shown in figure neglect the masses of the pulley and string and also friction. The accelerations of blocks A and B are

- (A)  $g, g/2$   
(B)  $g/2, g$   
(C)  $3g/2, 3g/4$   
(D)  $g, g$

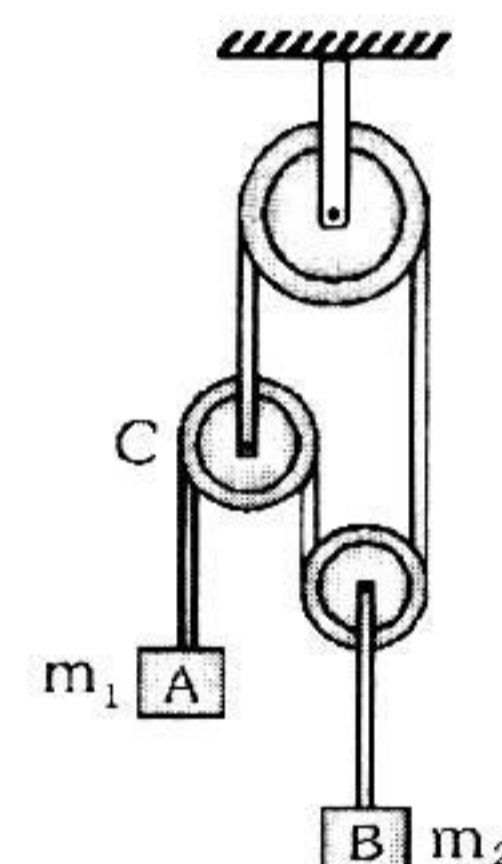

17. A block is placed on an inclined plane moving towards right horizontally with an acceleration  $a_0 = g$ . The length of the plane  $AC = 1\text{m}$ . Friction is absent everywhere. The time taken by the block to reach from C to A is

- ( $g = 10\text{ m/s}^2$ )  
(A) 1.2 s (B) 0.74 s  
(C) 2.56 s (D) 0.42 s

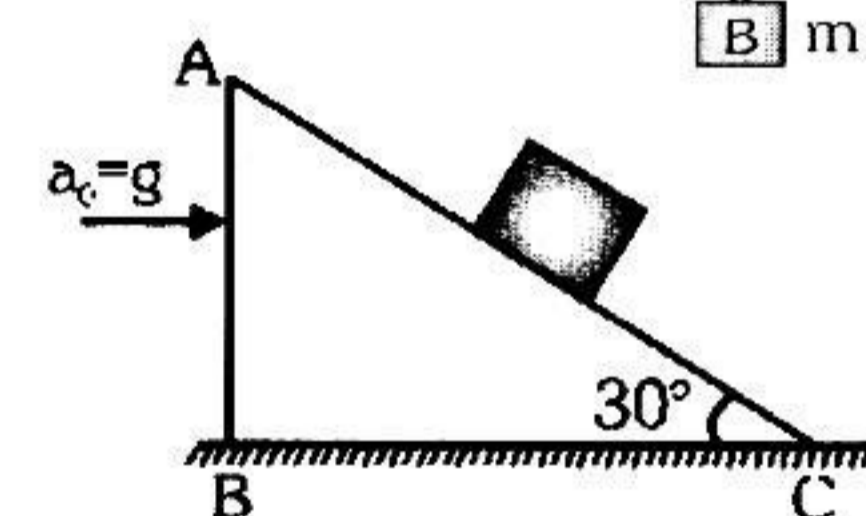

18. In the arrangement shown in figure pulley A and B are massless and the thread is inextensible. Mass of pulley C is equal to  $m$ . If friction in all the pulleys is negligible, then

- (A) tension in thread is equal to  $1/2\text{ mg}$   
(B) acceleration of pulley C is equal to  $g/2$  (downward)  
(C) acceleration of pulley A is equal to  $g/2$  (upward)  
(D) acceleration of pulley A is equal to  $2g$  (upward)

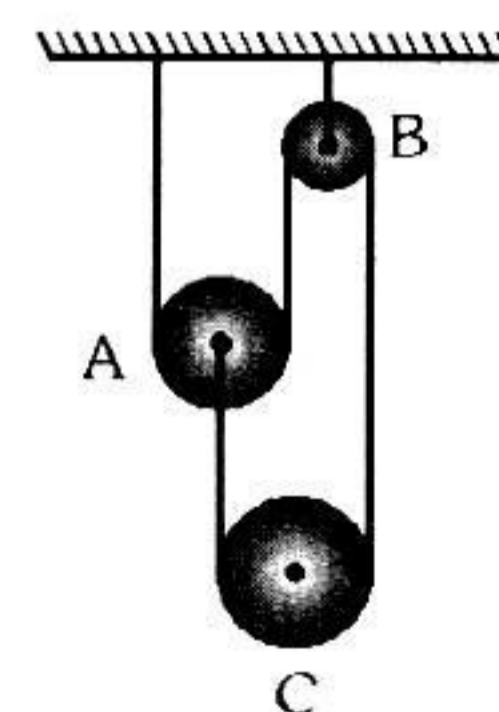

19. A sphere of mass  $m$  is kept in equilibrium with the help of several springs as shown in the figure. Measurement shows that one of the springs applies a force  $\vec{F}$  on the sphere. With what acceleration the sphere will move immediately after this particular spring is cut?

- (A) zero (B)  $\vec{F}/m$   
(C)  $-\vec{F}/m$  (D) insufficient information

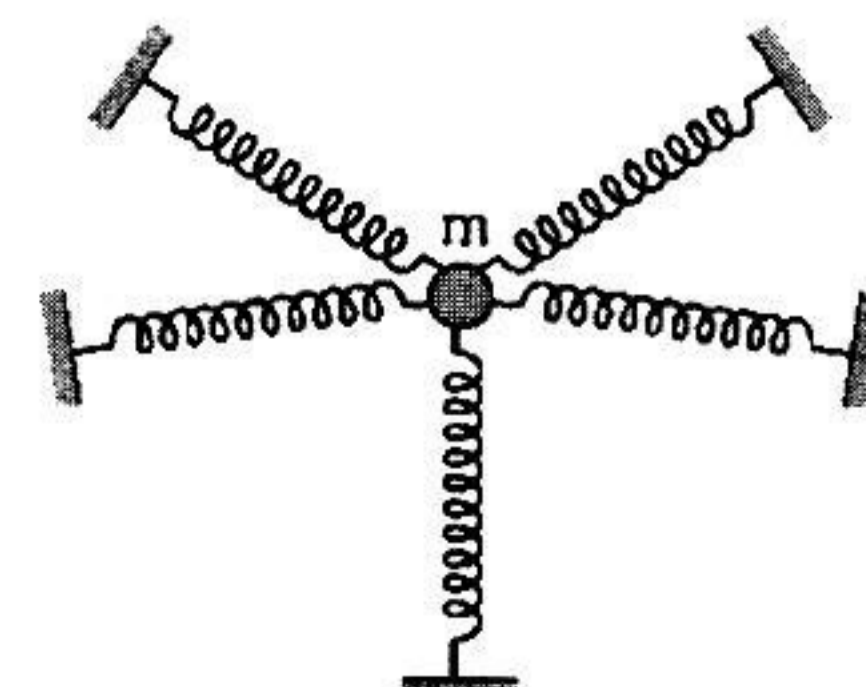

20. Same spring is attached with 2kg, 3kg and 1 kg blocks in three different cases as shown in figure. If  $x_1$ ,  $x_2$  and  $x_3$  be the extensions in the spring in these three cases then

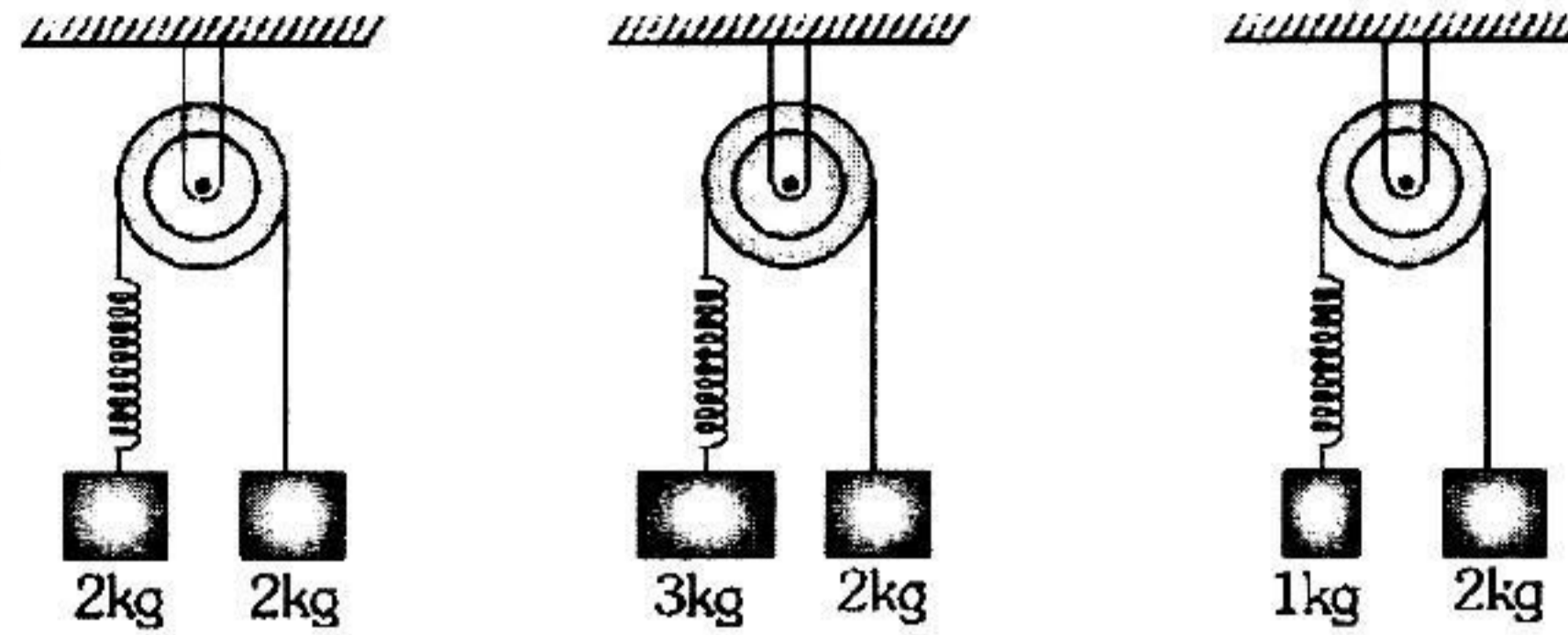

- (A)  $x_1 = 0$ ,  $x_3 > x_2$     (B)  $x_2 > x_1 > x_3$     (C)  $x_3 > x_1 > x_2$     (D)  $x_1 > x_2 > x_3$

21. The adjoining figure shows a force of 40 N pulling a body of mass 5 kg in a direction  $30^\circ$  above the horizontal. The body is in rest on a smooth horizontal surface. Assuming acceleration of free-fall is  $10 \text{ m/s}^2$ . Which of the following statements I and II is/are correct?

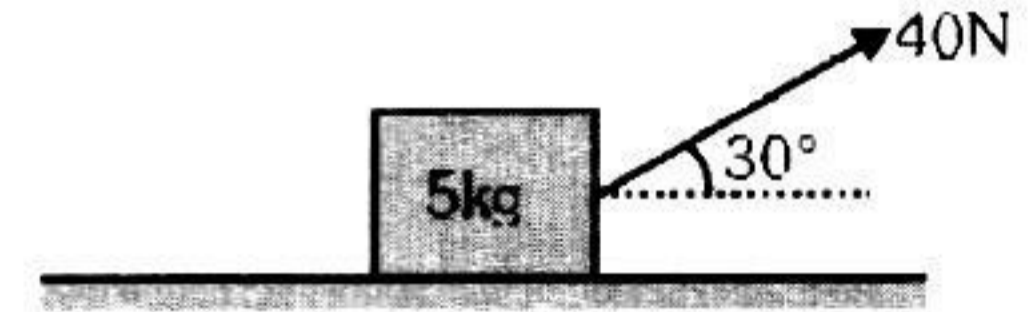

- I. The weight of the 5 kg mass acts vertically downwards  
 II. The net vertical force acting on the body is 30 N.

- (A) Only I.    (B) Only II.    (C) Both I and II.    (D) None of them

22. A constant force  $F$  is applied in horizontal direction as shown. Contact force between  $M$  and  $m$  is  $N$  and between  $m$  and  $M'$  is  $N'$  then

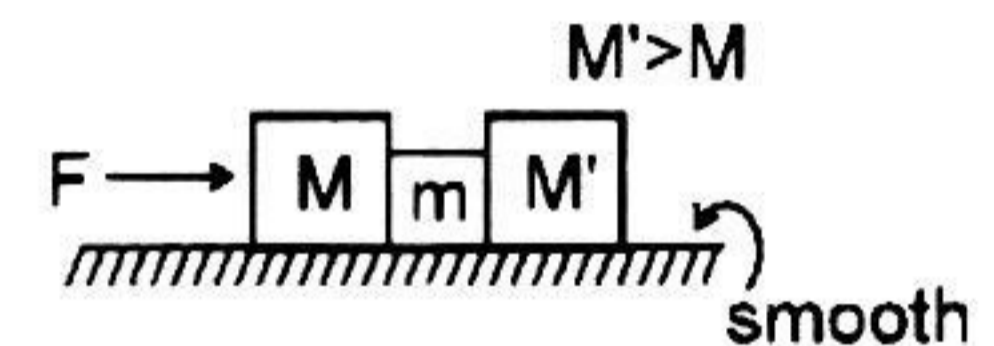

- (A)  $N$  or  $N'$  equal    (B)  $N > N'$   
 (C)  $N' > N$     (D) cannot be determined

23. Two masses  $M_1$  and  $M_2$  are attached to the ends of a string which passes over a pulley attached to the top of a double inclined plane of angles of inclination  $\alpha$  and  $\beta$ . If  $M_2 > M_1$ , the acceleration  $a$  of the system can be given by (neglect friction) :

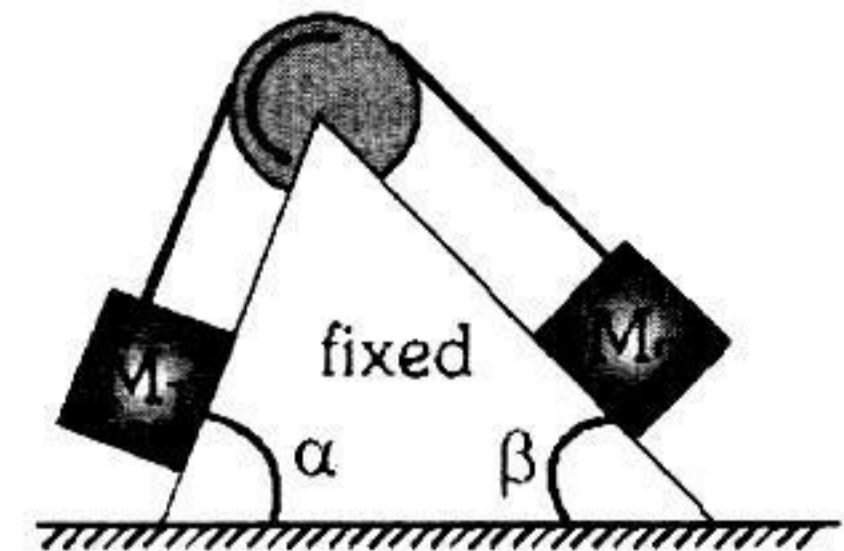

- (A)  $\frac{M_2 g (\sin \beta)}{M_1 + M_2}$     (B)  $\frac{M_1 g (\sin \alpha)}{M_1 + M_2}$   
 (C)  $\left( \frac{M_2 \sin \beta - M_1 \sin \alpha}{M_1 + M_2} \right) g$     (D) zero

24. In the figure shown block B moves down with a velocity 10 m/s. The velocity of A in the position shown is

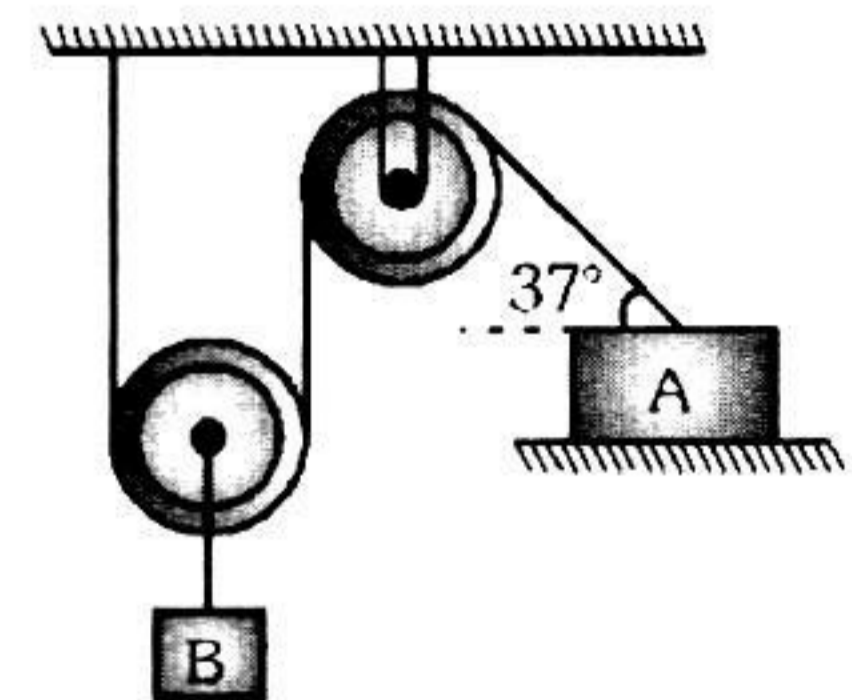

- (A) 12.5 m/s    (B) 25 m/s  
 (C) 6.25 m/s    (D) None of these

25. Three masses of 1 kg, 6 kg and 3 kg are connected to each other with threads and are placed on table as shown in figure, What is the acceleration with which the system is moving? Take  $g = 10 \text{ m/s}^2$ .

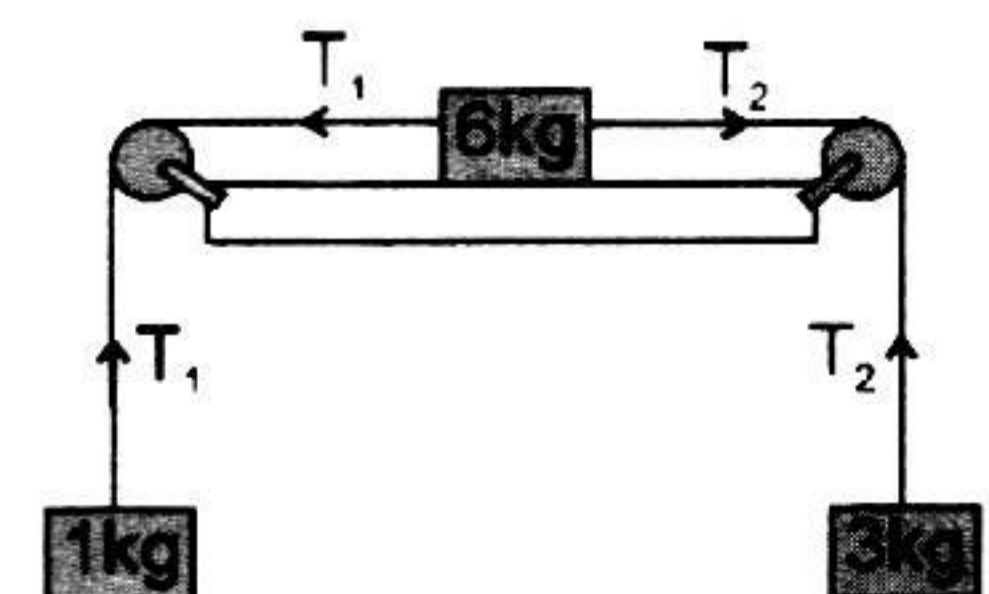

- (A) Zero    (B)  $1 \text{ m/s}^2$   
 (C)  $2 \text{ m/s}^2$     (D)  $3 \text{ m/s}^2$

26. A light string fixed at one end to a clamp on ground passes over a fixed pulley and hangs at the other side. It makes an angle of  $30^\circ$  with the ground. A monkey of mass 5 kg climbs up the rope. The clamp can tolerate a vertical force of 40 N only. The maximum acceleration in upward direction with which the monkey can climb safely is (neglect friction and take  $g = 10 \text{ m/s}^2$ ) :

- (A)  $2 \text{ m/s}^2$  (B)  $4 \text{ m/s}^2$   
(C)  $6 \text{ m/s}^2$  (D)  $8 \text{ m/s}^2$

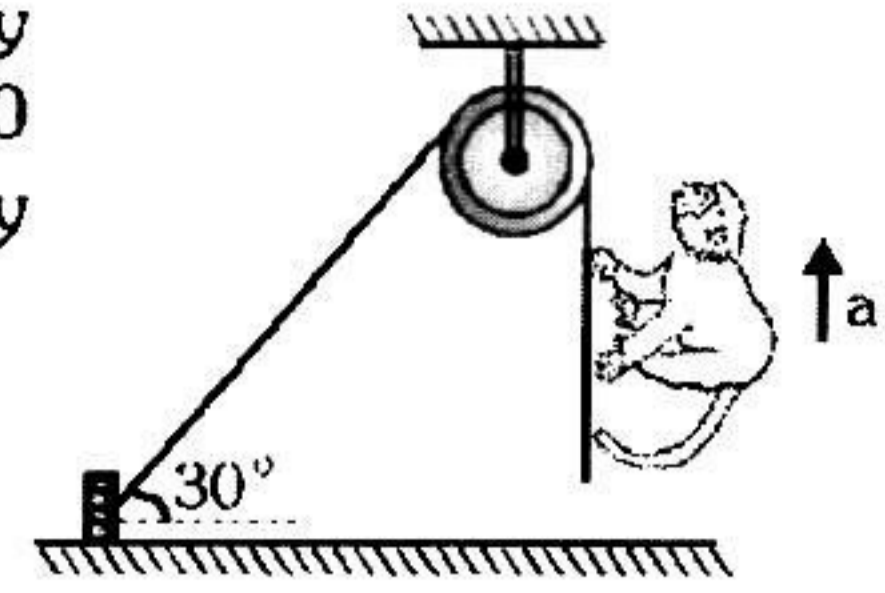

27. Two masses of 10 kg and 20 kg respectively are connected by a massless spring as shown in figure. A force of 200 N acts on the 20 kg mass at the instant when the 10 kg mass has an acceleration of  $12 \text{ ms}^{-2}$  towards right, the acceleration of the 20 kg mass is :

- (A)  $2 \text{ ms}^{-2}$  (B)  $4 \text{ ms}^{-2}$   
(C)  $10 \text{ ms}^{-2}$  (D)  $20 \text{ ms}^{-2}$

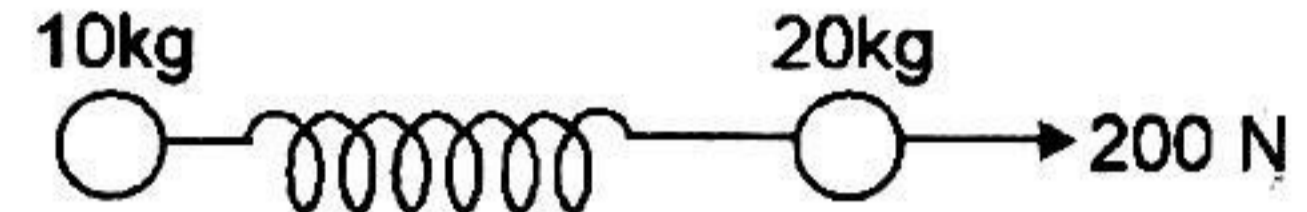

28. In the arrangement shown in the figure all surfaces are frictionless, the masses of the block are  $m_1 = 20 \text{ kg}$  and  $m_2 = 30 \text{ kg}$ . The accelerations of masses  $m_1$  and  $m_2$  will be if  $F = 180 \text{ N}$ .

- (A)  $a_{m_1} = 9 \text{ m/s}^2, a_{m_2} = 0$  (B)  $a_{m_1} = 9 \text{ m/s}^2, a_{m_2} = 9 \text{ m/s}^2$   
(C)  $a_{m_1} = 0, a_{m_2} = 9 \text{ m/s}^2$  (D) None of these

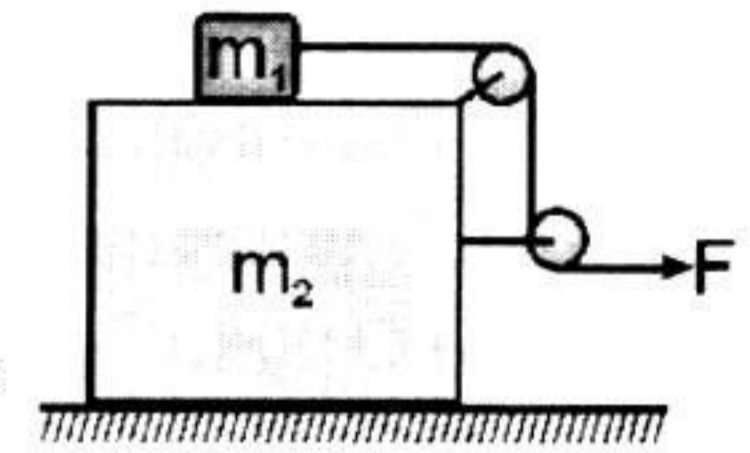

29. Three blocks A, B and C are suspended as shown in the figure. Mass of each blocks A and C is  $m$ . If system is in equilibrium and mass of B is  $M$ , then :

- (A)  $M = 2m$  (B)  $M < 2m$   
(C)  $M > 2m$  (D)  $M = m$

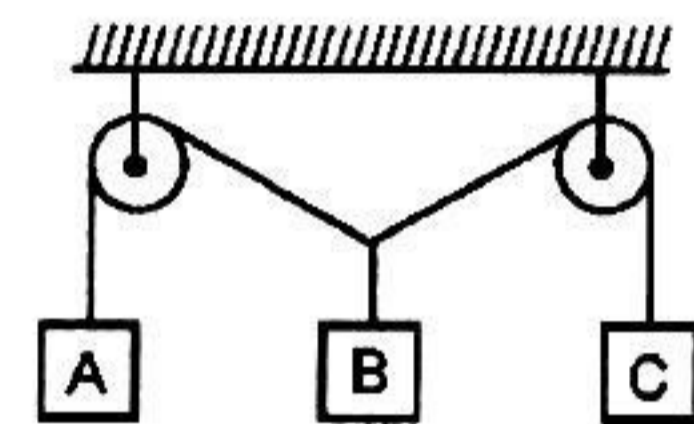

30. Block A of mass  $m$  is placed over a wedge B of same mass  $m$ . Assuming all surfaces to be smooth. The displacement of block A in 1 s if the system is released from rest is

- (A)  $g \frac{(1 + \sin^2 \theta)}{(1 - \sin^2 \theta)}$  (B)  $\frac{g \sin \theta}{2}$   
(C)  $g \frac{\cos^2 \theta}{1 + \sin^2 \theta}$  (D)  $g \frac{\sin^2 \theta}{1 + \sin^2 \theta}$

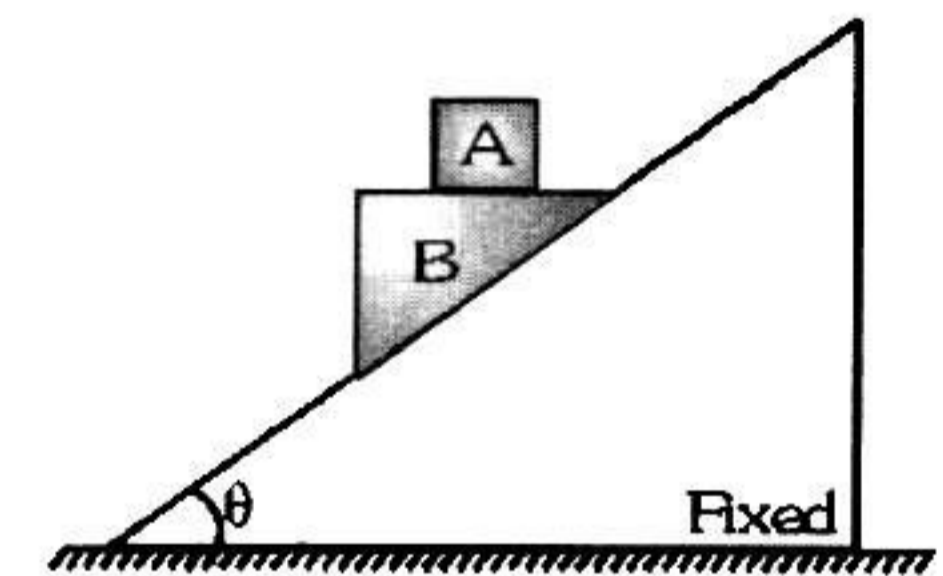

31. A flexible chain of weight  $W$  hangs between two fixed points A and B at the same level. The inclination of the chain with the horizontal at the two points of support is  $\theta$ . What is the tension of the chain at the endpoint ?

- (A)  $\frac{W}{2} \operatorname{cosec} \theta$  (B)  $\frac{W}{2} \sec \theta$   
(C)  $W \cos \theta$  (D)  $\frac{W}{2} \sin \theta$

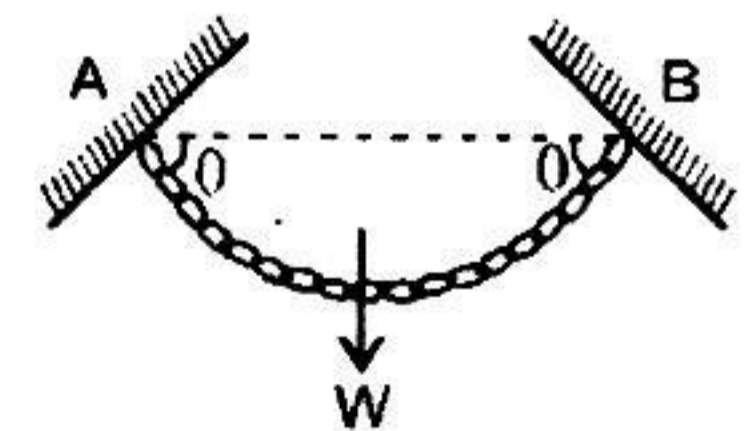

32. What is the tension at point A in the previous question ?

- (A)  $\frac{W}{2} \operatorname{cosec} \theta$  (B)  $\frac{W}{2} \sec \theta$   
(C)  $\frac{W}{2} \cot \theta$  (D)  $\frac{W}{2} \sin \theta$

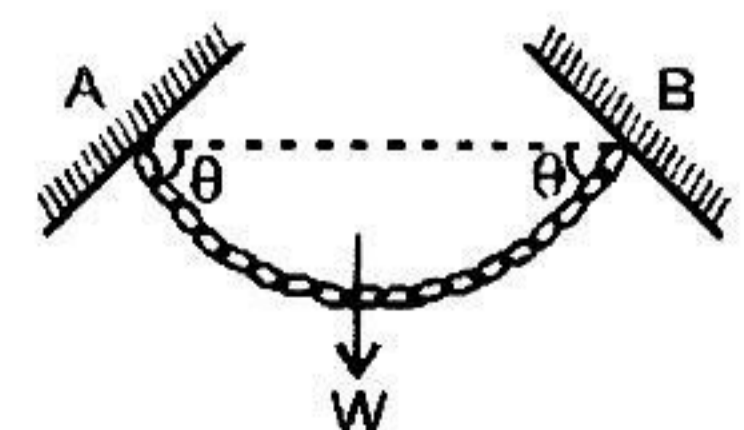

33. Two masses  $m$  and  $M$  are attached with strings as shown. For the system to be in equilibrium we have

(A)  $\tan \theta = 1 + \frac{2M}{m}$  (B)  $\tan \theta = 1 + \frac{2m}{M}$   
 (C)  $\tan \theta = 1 + \frac{M}{2m}$  (D)  $\tan \theta = 1 + \frac{m}{2M}$

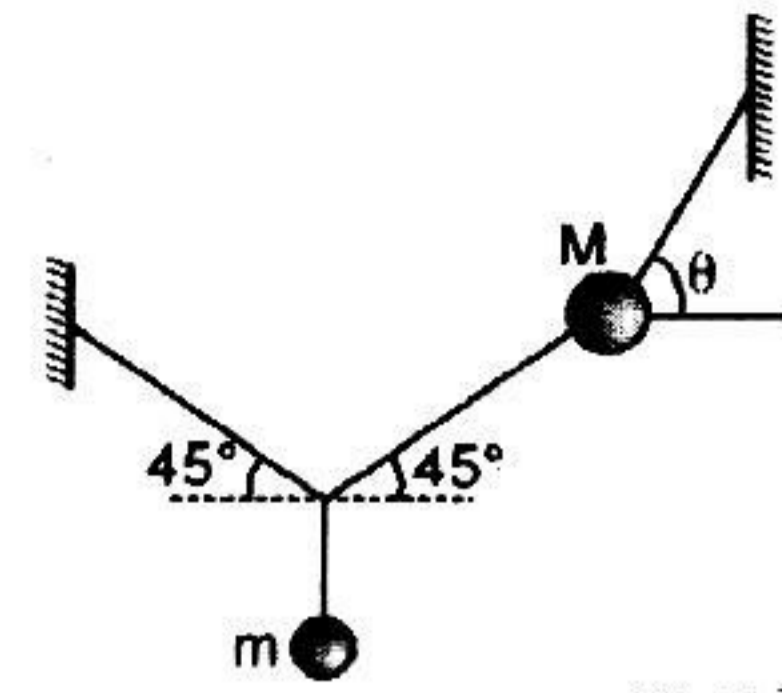

34. Reading shown in two spring balances  $S_1$  and  $S_2$  is 90 kg and 30 kg respectively and lift is accelerating upwards with acceleration  $10 \text{ m/s}^2$ . The mass is stationary with respect to lift. Then the mass of the block will be :

(A) 60 kg (B) 30 kg  
 (C) 120 kg (D) None of these

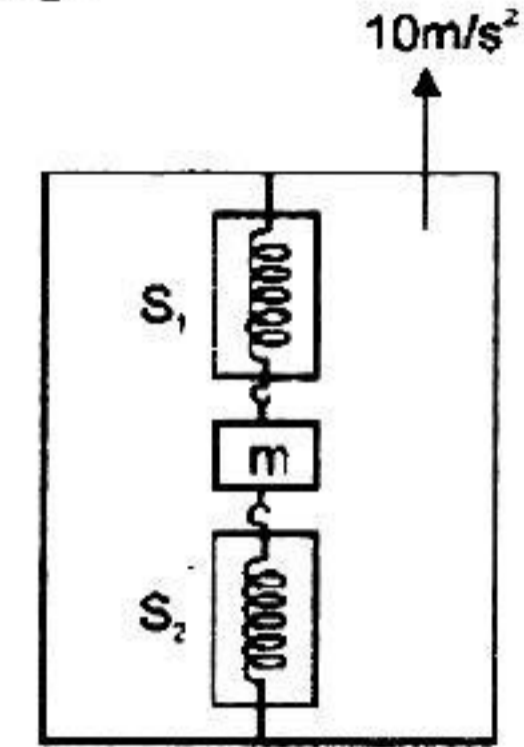

35. Five persons A, B, C, D & E are pulling a cart of mass 100 kg on a smooth surface and cart is moving with acceleration  $3 \text{ m/s}^2$  in east direction. When person 'A' stops pulling, it moves with acceleration  $1 \text{ m/s}^2$  in the west direction. When person 'B' stops pulling, it moves with acceleration  $24 \text{ m/s}^2$  in the north direction. The magnitude of acceleration of the cart when only A & B pull the cart keeping their directions same as the old directions, is :

(A)  $26 \text{ m/s}^2$  (B)  $3\sqrt{71} \text{ m/s}^2$  (C)  $25 \text{ m/s}^2$  (D)  $30 \text{ m/s}^2$

36. Four identical metal butterflies are hanging from a light string of length  $5l$  at equally placed points as shown. The ends of the string are attached to a horizontal fixed support. The middle section of the string is horizontal. The relation between the angle  $\theta_1$  and  $\theta_2$  is given by :

(A)  $\sin \theta_1 = 2 \sin \theta_2$  (B)  $2 \cos \theta_1 = \sin \theta_2$   
 (C)  $\tan \theta_1 = 2 \tan \theta_2$  (D)  $\theta_2 < \theta_1$  and no other conclusion can be derived.

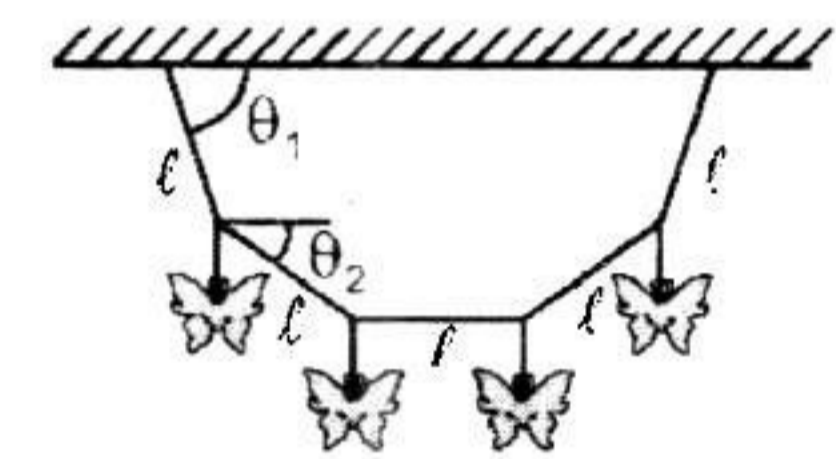

37. In the figure shown the velocity of lift is  $2 \text{ m/s}$  while string is winding on the motor shaft with velocity  $2 \text{ m/s}$  and block A is moving downwards with a velocity of  $2 \text{ m/s}$ , then find out the velocity of block B.

(A)  $2 \text{ m/s} \uparrow$  (B)  $2 \text{ m/s} \downarrow$   
 (C)  $4 \text{ m/s} \uparrow$  (D)  $8 \text{ m/s} \uparrow$

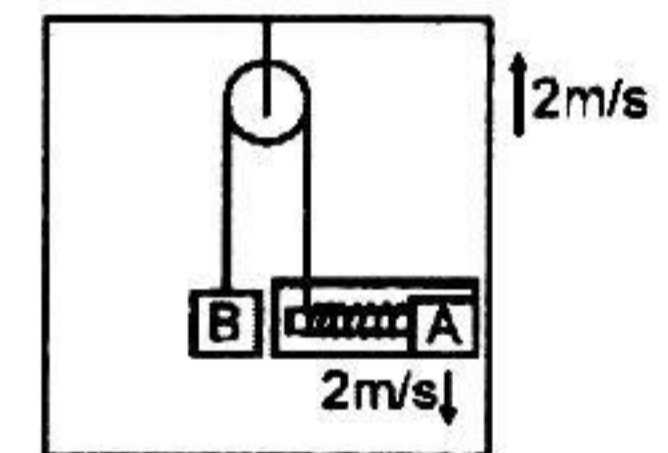

38. If block A is moving with an acceleration of  $5 \text{ m/s}^2$ , the acceleration of B w.r.t. ground is :

(A)  $5 \text{ m/s}^2$  (B)  $5\sqrt{2} \text{ m/s}^2$   
 (C)  $5\sqrt{5} \text{ m/s}^2$  (D)  $10 \text{ m/s}^2$

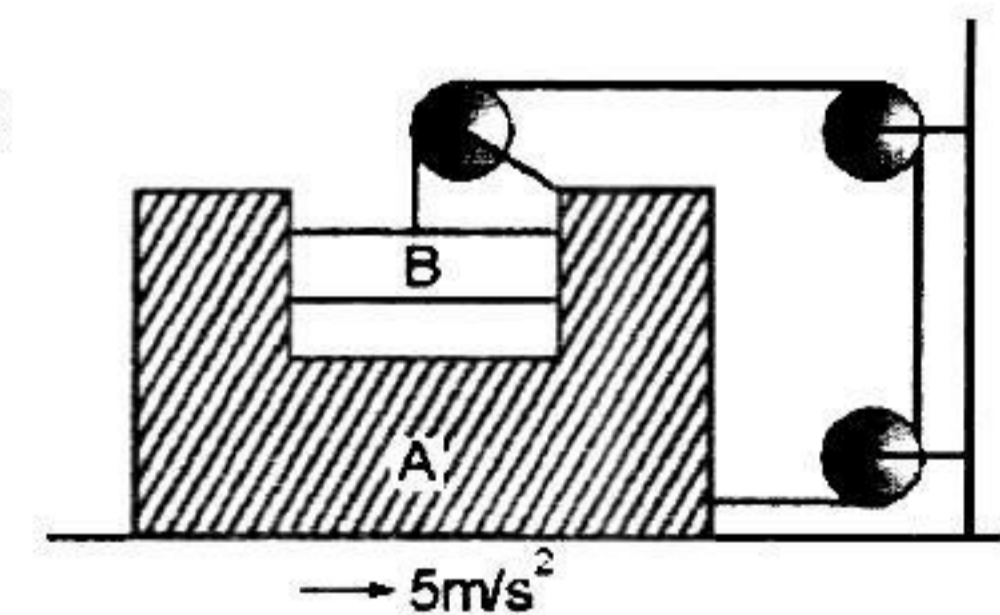

39. Two blocks of masses  $m_1$  and  $m_2$  are connected as shown in the figure. The acceleration of the block  $m_2$  is:

(A)  $\frac{m_2 g}{m_1 + m_2}$  (B)  $\frac{m_1 g}{m_1 + m_2}$   
 (C)  $\frac{4 m_2 g - m_1 g}{m_1 + m_2}$  (D)  $\frac{m_2 g}{m_1 + 4 m_2}$

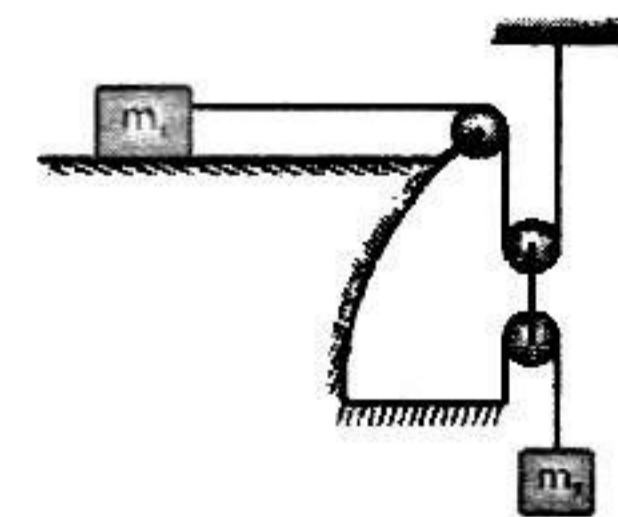

40. A uniform rope of length  $L$  and mass  $M$  is placed on a smooth fixed wedge as shown. Both ends of rope are at same horizontal level. The rope is initially released from rest, then the magnitude of initial acceleration of rope is :

(A) Zero (B)  $M(\cos \alpha - \cos \beta) g$   
 (C)  $M(\tan \alpha - \tan \beta) g$  (D) None of these

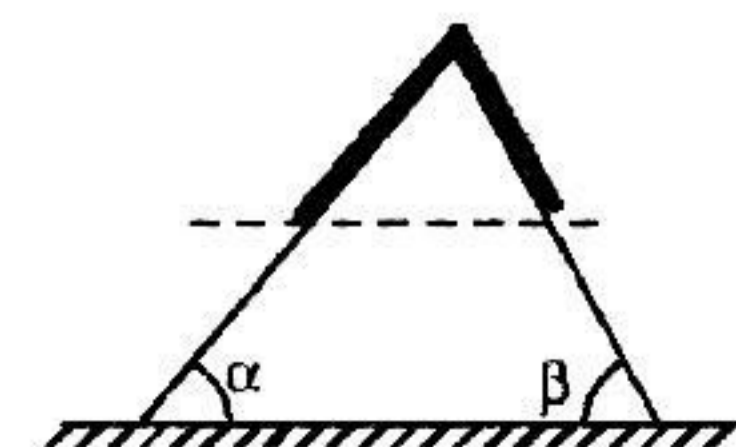

41. An inclined plane makes an angle  $30^\circ$  with the horizontal. A groove  $OA=5\text{m}$  cut in the plane makes an angle  $30^\circ$  with  $OX$ . A short smooth cylinder is free to slide down the influence of gravity. The time taken by the cylinder to reach from A to O is (if released from rest from A) ( $g = 10 \text{ m/s}^2$ )
- (A) 4s (B) 2s  
(C)  $2\sqrt{2} \text{ s}$  (D) 1s

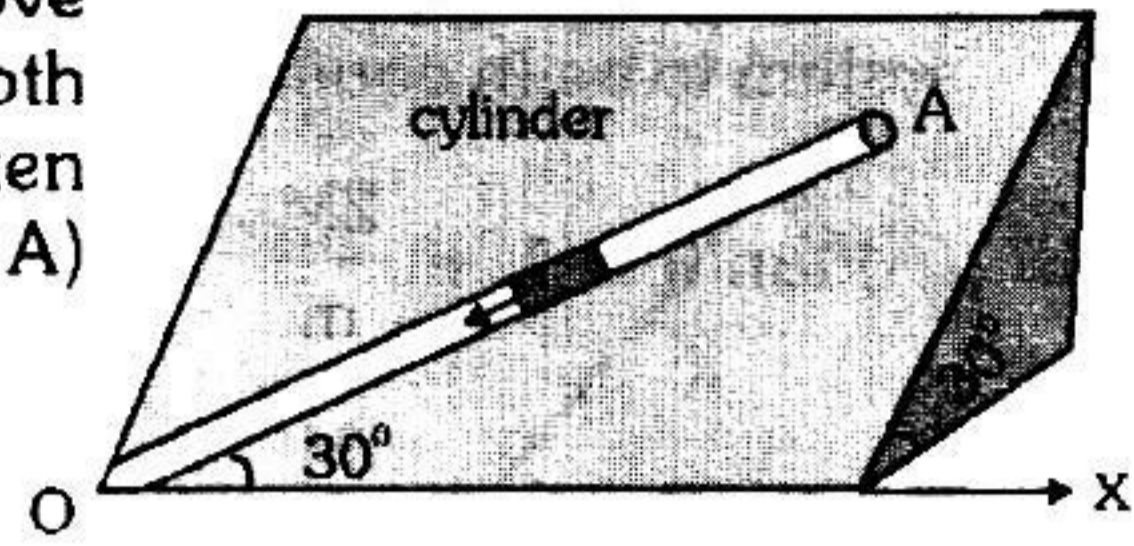

42. A bob is hanging over a pulley inside a car through a string. The second end of the string is in the hand of a person standing in the car. The car is moving with constant acceleration 'a' directed horizontally as shown in figure. Other end of the string is pulled with constant acceleration 'a' (relative to car) vertically. The tension in the string is equal to (assuming  $\theta$  remains constant)
- (A)  $m\sqrt{g^2 + a^2}$  (B)  $m\sqrt{g^2 + a^2} - ma$   
(C)  $m\sqrt{g^2 + a^2} + ma$  (D)  $m(g + a)$

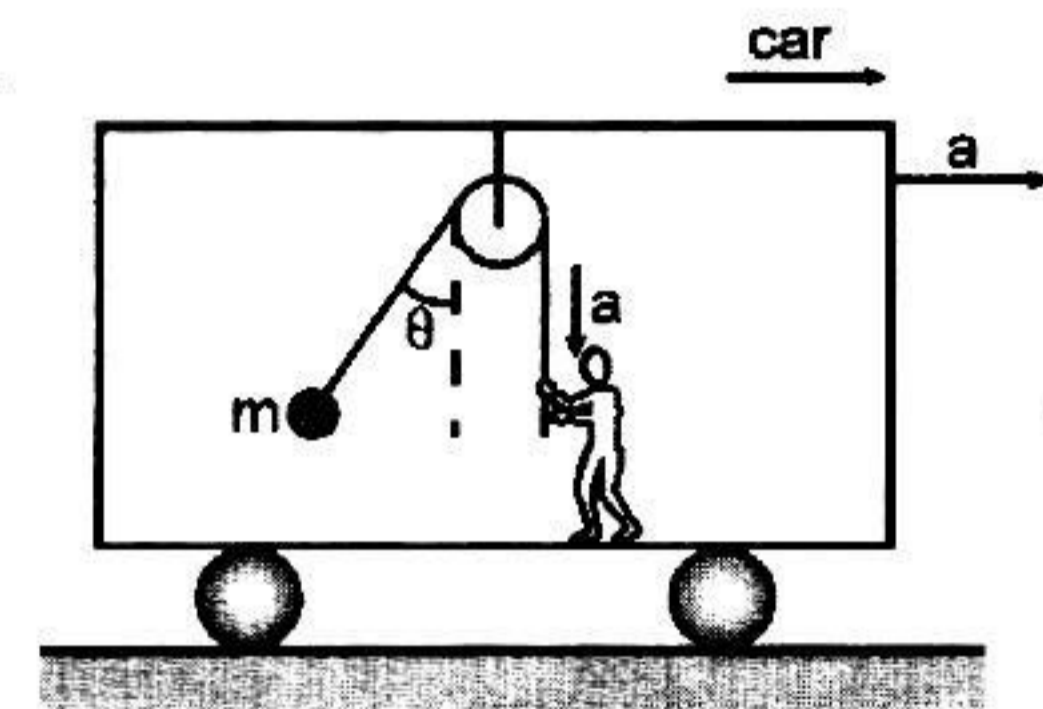

43. In the figure a block 'A' of mass 'm' is attached at one end of a light spring and the other end of the spring is connected to another block 'B' of mass  $2m$  through a light string. 'A' is held and B is in static equilibrium. Now A is released. The acceleration of A just after that instant is 'a'. In the next case, B is held and A is in static equilibrium. Now when B is released, its acceleration immediately after the release is 'b'. The value of  $a/b$  is : (Pulley, string and the spring are massless)
- (A) 0 (B) undefined  
(C) 2 (D)  $\frac{1}{2}$

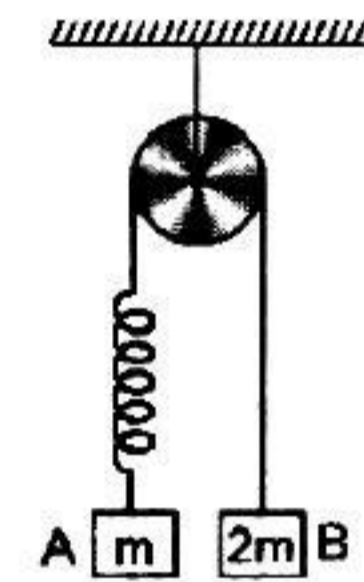

44. System is shown in the figure and man is pulling the rope from both sides with constant speed 'u'. Then the speed of the block will be:
- (A)  $\frac{3u}{4}$  (B)  $\frac{3u}{2}$   
(C)  $\frac{u}{4}$  (D) none of these

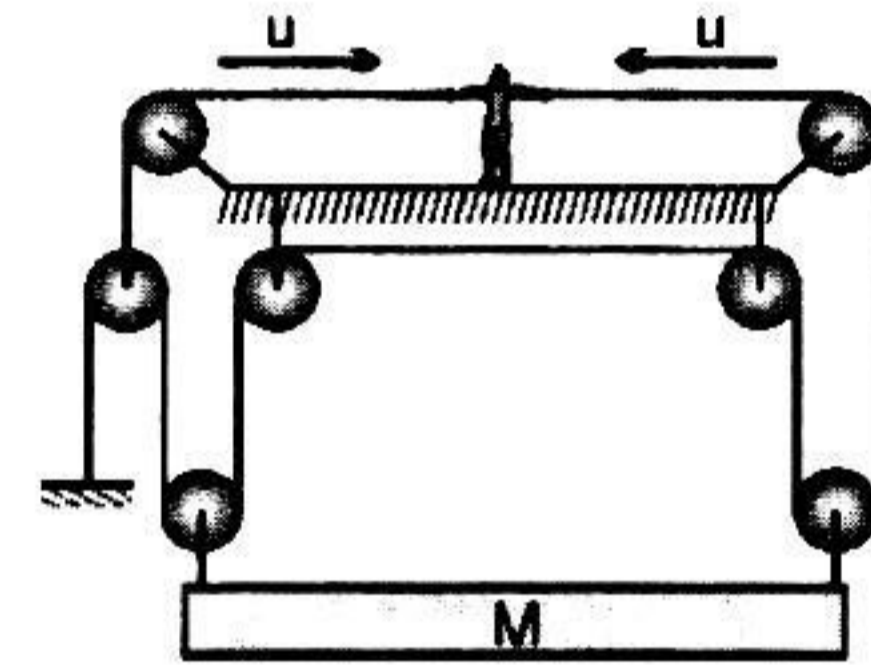

45. System is shown in the figure. Assume that cylinder remains in contact with the two wedges. The velocity of cylinder is
- (A)  $\sqrt{19 - 4\sqrt{3}} \frac{u}{2} \text{ m/s}$  (B)  $\frac{\sqrt{13}u}{2} \text{ m/s}$   
(C)  $\sqrt{3}u \text{ m/s}$  (D)  $\sqrt{7}u \text{ m/s}$

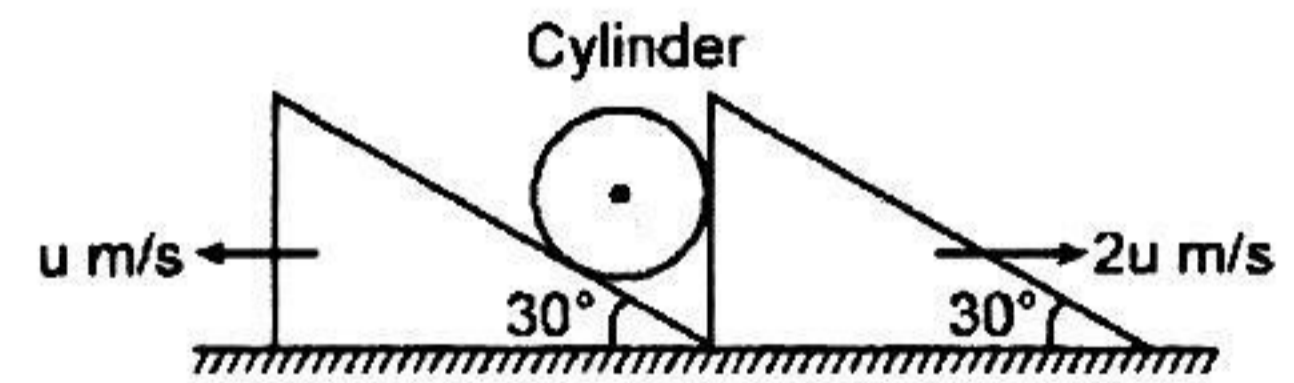

46. System is shown in the figure. Velocity of sphere A is 9 m/s. Then speed of sphere B at the given instant will be :
- (A) 9 m/s (B) 12 m/s  
(C)  $\frac{45}{4} \text{ m/s}$  (D) none of these

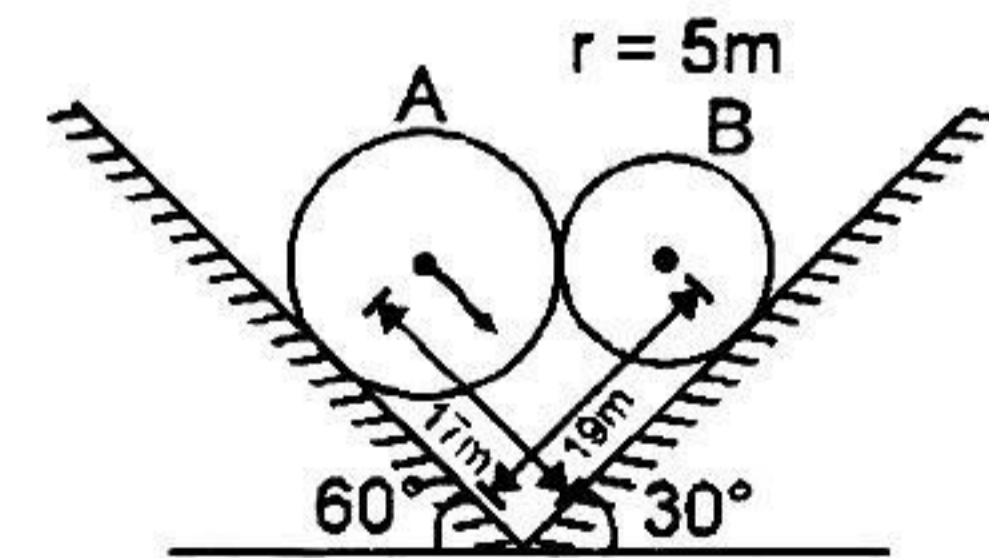

47. System is shown in figure and wedge is moving towards left with speed 2 m/s. Then velocity of the block B will be:
- (A)  $\sqrt{3} \text{ m/s}$  (B) 1 m/s  
(C) 2 m/s (D) 0 m/s

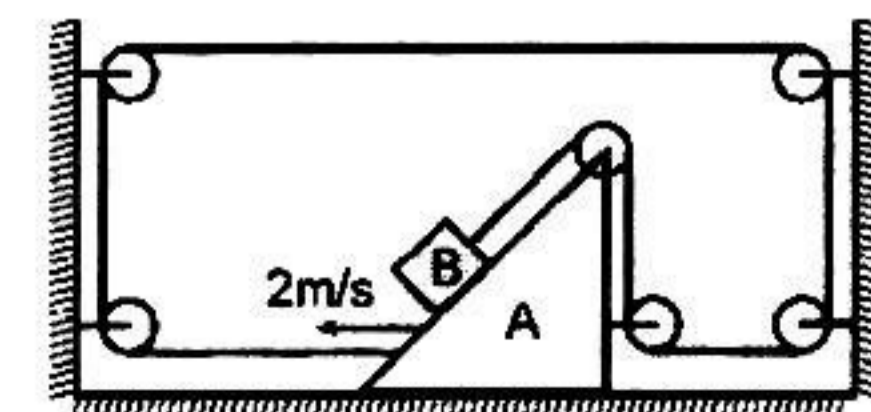

# ANSWERS

## EXERCISE-1

<b>Que.</b>	<b>1</b>	<b>2</b>	<b>3</b>	<b>4</b>	<b>5</b>	<b>6</b>	<b>7</b>	<b>8</b>	<b>9</b>	<b>10</b>	<b>11</b>	<b>12</b>	<b>13</b>	<b>14</b>	<b>15</b>
<b>Ans.</b>	B	C	D	B	B	C	A	C	C	C	D	B	C	D	A
<b>Que.</b>	<b>16</b>	<b>17</b>	<b>18</b>	<b>19</b>	<b>20</b>	<b>21</b>	<b>22</b>	<b>23</b>	<b>24</b>	<b>25</b>	<b>26</b>	<b>27</b>	<b>28</b>	<b>29</b>	<b>30</b>
<b>Ans.</b>	D	B	D	C	B	A	B	C	B	C	C	B	A	B	D
<b>Que.</b>	<b>31</b>	<b>32</b>	<b>33</b>	<b>34</b>	<b>35</b>	<b>36</b>	<b>37</b>	<b>38</b>	<b>39</b>	<b>40</b>	<b>41</b>	<b>42</b>	<b>43</b>	<b>44</b>	<b>45</b>
<b>Ans.</b>	A	C	A	B	C	C	D	C	A	A	B	C	C	A	D
<b>Que.</b>	<b>46</b>	<b>47</b>													
<b>Ans.</b>	B	C													

## EXERCISE-02

## MCQ (ONE OR MORE CHOICE CORRECT)

1. In the following arrangement the system is initially at rest. The 5 kg block is now released. Assuming the pulleys and string to be massless and smooth, the acceleration of blocks is

(A)  $a_A = \frac{g}{7}$

(B)  $a_B = 0 \text{ m/s}^2$

(C)  $a_c = \frac{g}{14}$

(D)  $2a_C = a_A$

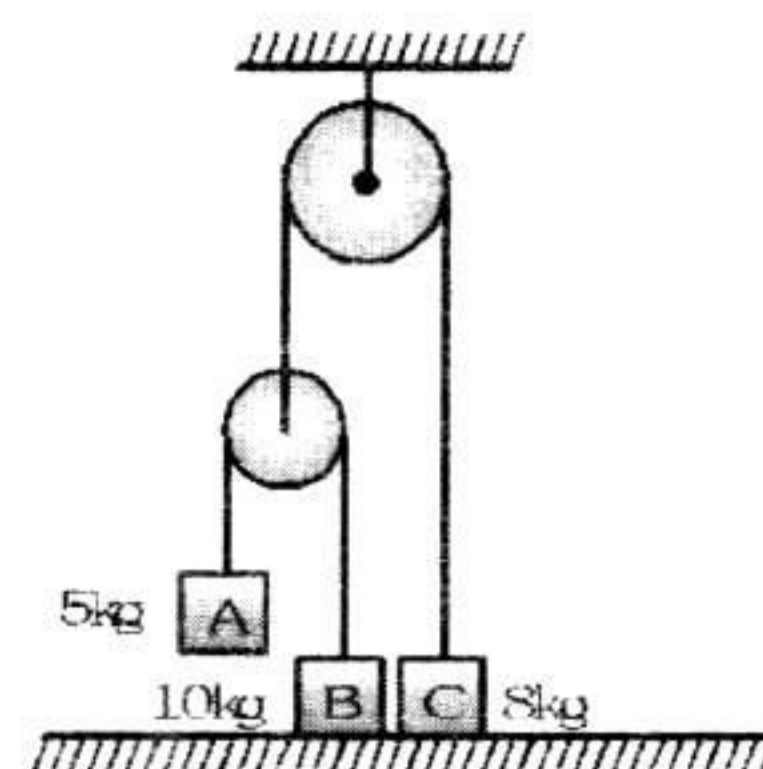

2. Two blocks A and B of equal mass  $m$  are connected through a massless string and arranged as shown in figure. Friction is absent everywhere. When the system is released from rest, then

(A) tension in string is  $\frac{mg}{2}$

(B) tension in string is  $\frac{mg}{4}$

(C) acceleration of A is  $\frac{g}{2}$

(D) acceleration of A is  $\frac{3}{4}g$

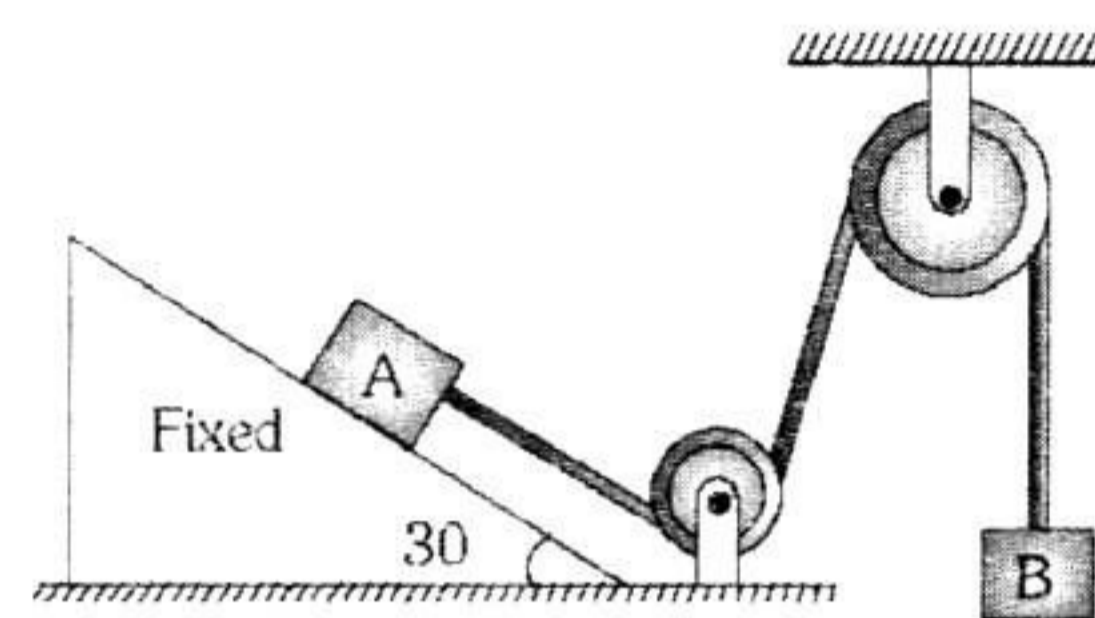

3. In the arrangement shown in figure all surfaces are smooth. Select the correct alternative/(s)

(A) for any value of  $\theta$  acceleration of A and B are equal

(B) contact force between the two blocks is zero only if  $\frac{m_A}{m_B} = \tan\theta$

(C) contact force between the two blocks is zero for any value of  $m_A$  or  $m_B$

(D) normal reactions exerted by the wedge on the blocks are equal

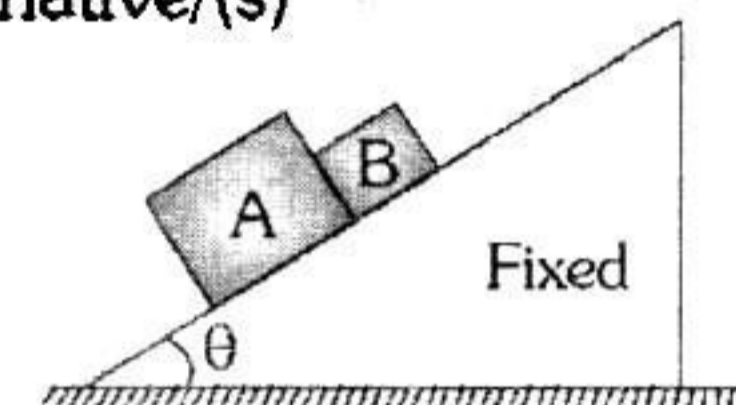

4. A cart of mass 0.5 kg is placed on a smooth surface and is connected by a string to a block of mass 0.2 kg. At the initial moment the cart moves to the left along a horizontal plane at a speed of 7 m/s. (Use  $g = 9.8 \text{ m/s}^2$ )

(A) The acceleration of the cart is  $\frac{2g}{7}$  towards right.

(B) The cart comes to momentary rest after 2.5 s.

(C) The distance travelled by the cart in the first 5s is 17.5 m.

(D) The velocity of the cart after 5s will be same as initial velocity.

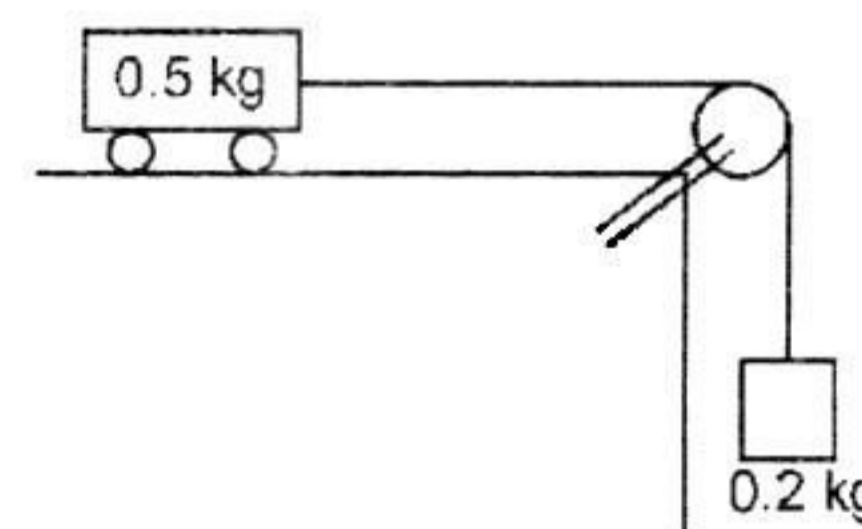

5. A trolley of mass 8 kg is standing on a frictionless surface inside which an object of mass 2 kg is suspended. A constant force  $F$  starts acting on the trolley as a result of which the string stood at an angle of  $37^\circ$  from the vertical. Then :

(A) acceleration of the trolley is  $40/3 \text{ m/sec}^2$

(B) force applied is 60 N

(C) force applied is 75 N

(D) tension in the string is 25 N

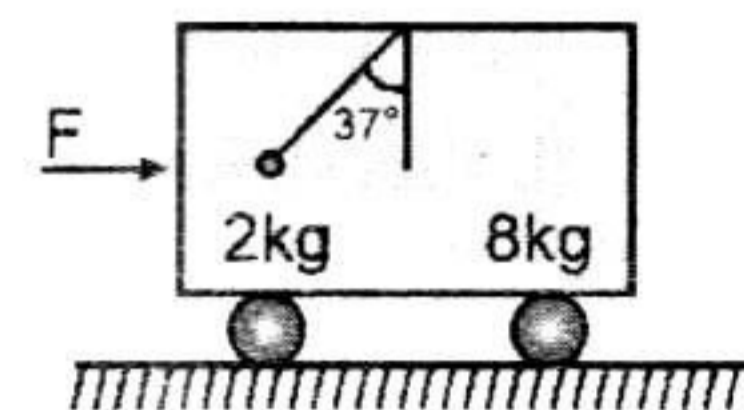

6. A painter is applying force himself to raise him and the box with an acceleration of  $5 \text{ m/s}^2$  by a massless rope and pulley arrangement as shown in figure. Mass of painter is 100 kg and that of box is 50 kg. If  $g = 10 \text{ m/s}^2$ , then:

(A) tension in the rope is 1125 N

(B) tension in the rope is 2250 N

(C) force of contact between the painter and the floor is 375 N

(D) force of contact between the painter and the floor is 750 N

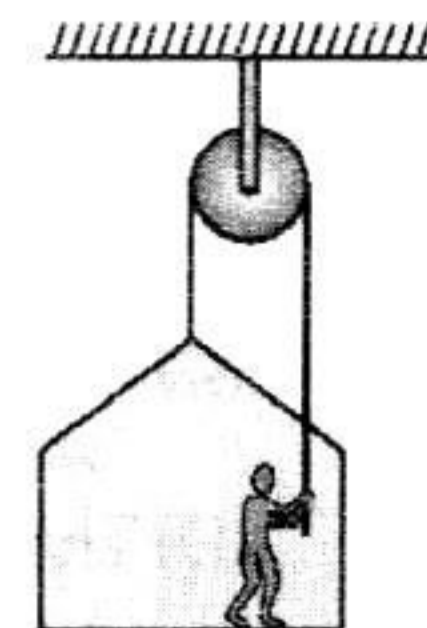

7. A trolley is accelerating down an incline of angle  $\theta$  with acceleration  $g \sin \theta$ . Which of the following is correct. ( $\alpha$  is the angle made by the string with vertical).
- (A)  $\alpha = \theta$   
 (B)  $\alpha = 0^\circ$   
 (C) Tension in the string,  $T = mg$   
 (D) Tension in the string,  $T = mg \sec \theta$

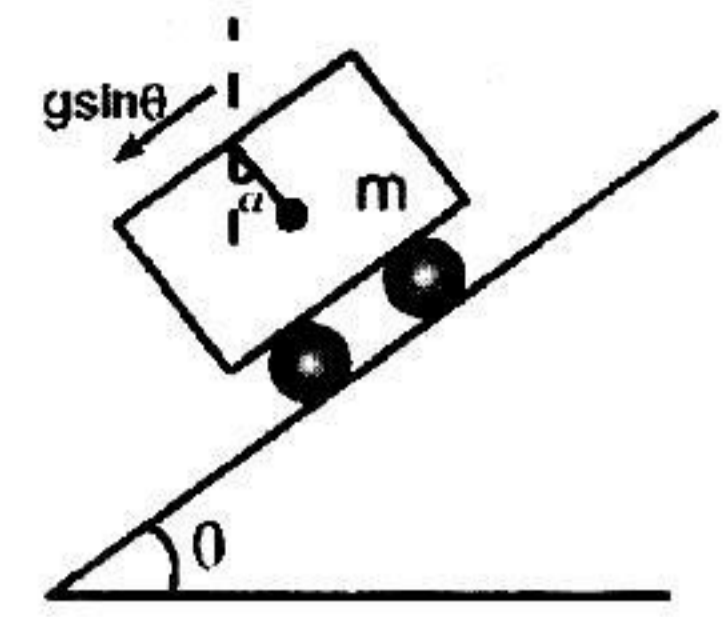

8. In the system shown in the figure  $m_1 > m_2$ . System is held at rest by thread BC. Just after the thread BC is burnt (neglect friction) :
- (A) acceleration of  $m_2$  will be upwards  
 (B) magnitude of acceleration of both blocks will be equal to  $\left(\frac{m_1 - m_2}{m_1 + m_2}\right) g$   
 (C) acceleration of  $m_1$  will be equal to zero  
 (D) magnitude of acceleration of two blocks will be non-zero and unequal.

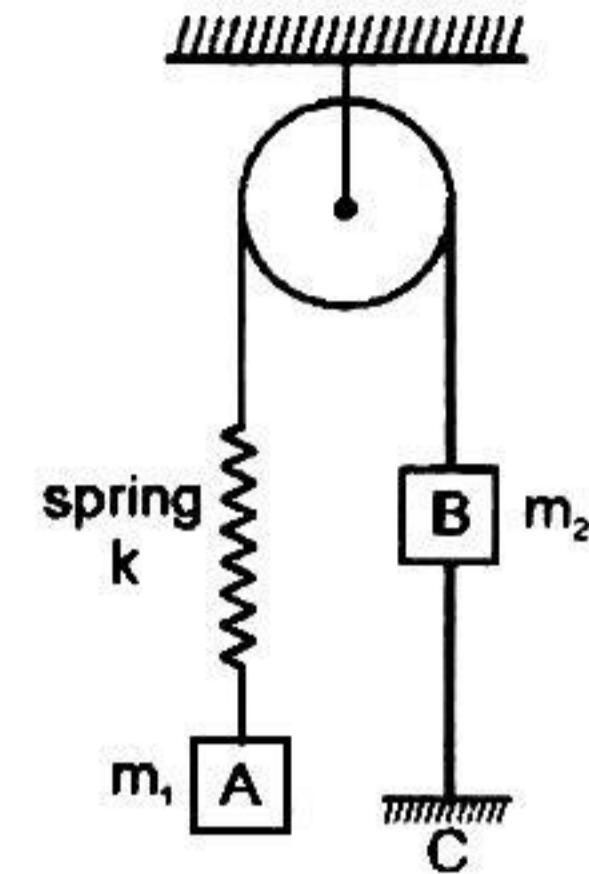

9. A string is wrapped round a log of wood and it is pulled with a force  $F$  as shown in the figure .
- (A) tension  $T$  in the string increases with increase in  $\theta$   
 (B) tension  $T$  in the string decreases with increase in  $\theta$   
 (C) tension  $T > F$  if  $\theta > \pi/3$   
 (D) tension  $T > F$  if  $\theta > \pi/4$

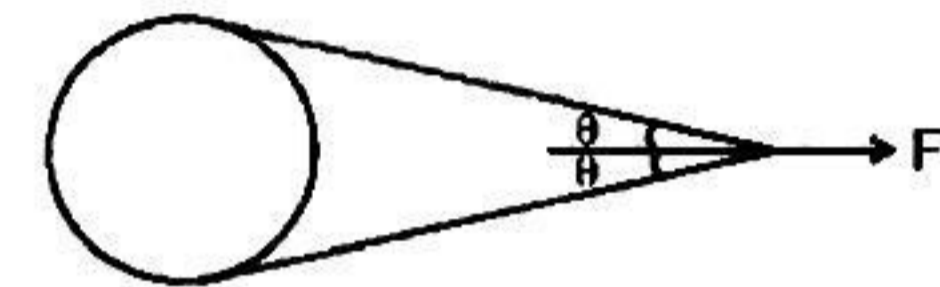

10. Two men of unequal masses hold on to the two sections of a light rope passing over a smooth light pulley. Which of the following is/are possible.
- (A) The lighter man is stationary while the heavier man slides down with some acceleration.  
 (B) The heavier man is stationary while the lighter man climbs up with some acceleration.  
 (C) The heavier man is stationary while the lighter man slips down with some acceleration.  
 (D) The lighter man is stationary while the heavier man climbs up with some acceleration.

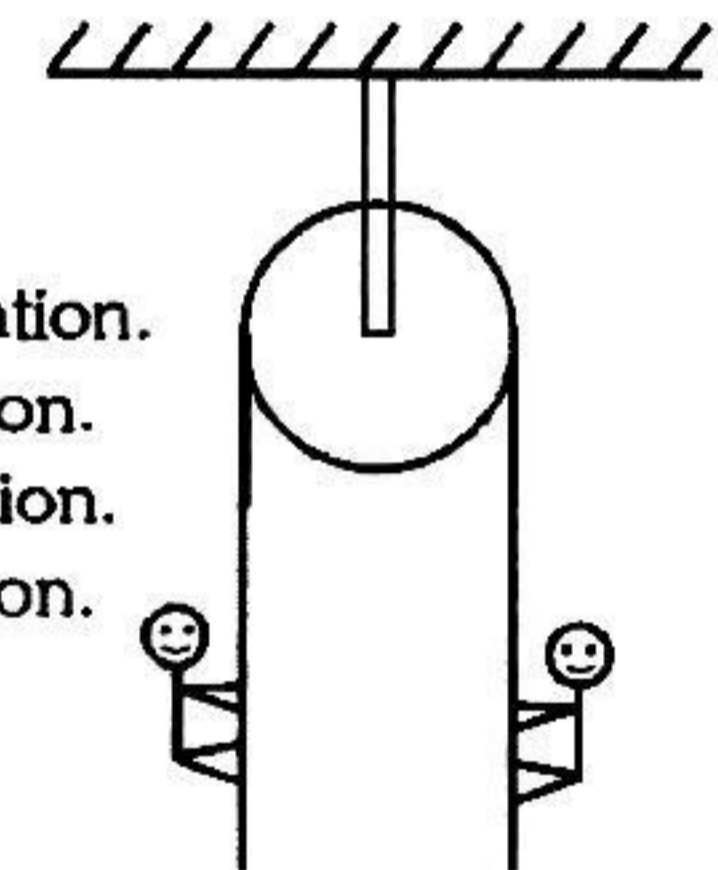

11. In the pulley system shown in figure the movable pulleys A, B and C are of mass 1 kg each. D and E are fixed pulleys. The strings are light and inextensible. Choose the correct alternative(s). All pulleys are frictionless.
- (A) tension in the string is  $20/3$  N  
 (B) acceleration of pulley A is  $g/3$  downward  
 (C) acceleration of pulley B is  $g/6$  upward  
 (D) acceleration of pulley C is  $g/3$  upward

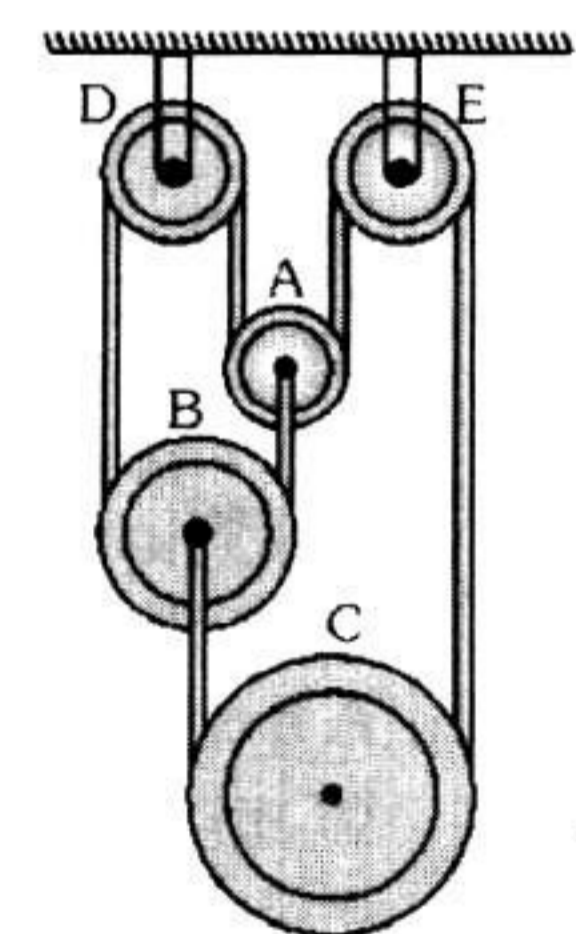

12. In the figure shown all the surface are smooth. All the blocks A, B and C are movable, x-axis is horizontal and y-axis vertical as shown. Just after the system is released from the position as shown.
- (A) Acceleration of 'A' relative to ground is in negative y-direction  
 (B) Acceleration of 'A' relative to B is in positive x-direction  
 (C) The horizontal acceleration of 'B' relative to ground is in negative x-direction.  
 (D) The acceleration of 'B' relative to ground directed along the inclined surface of 'C' is greater than  $g \sin \theta$ .

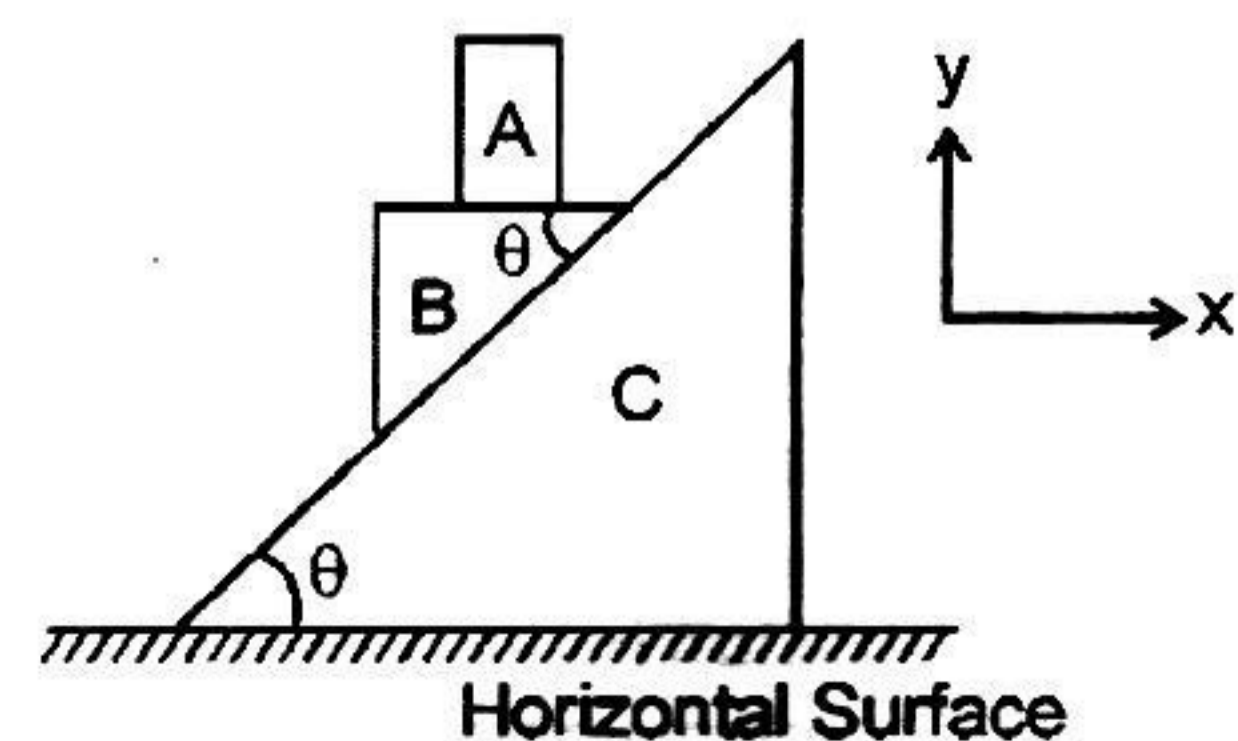

13. A block is attached with an ideal spring and string, and is in equilibrium as shown in figure. The acceleration of the block just after breaking the string is  $a_1$  and just after breaking the spring is  $a_2$ . Then

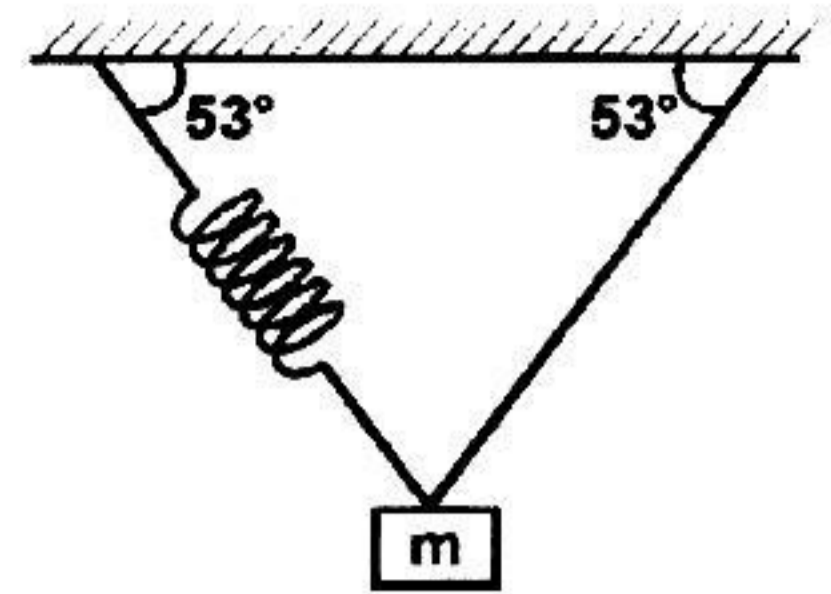

- (A)  $a_1 = \frac{5g}{8}$  (B)  $a_2 = \frac{3g}{5}$   
 (C)  $a_1 = \frac{g}{2}$  (D)  $a_2 = g$

14. A block B of mass 0.6 kg slides down the smooth face PR of a wedge A of mass 1.7 kg which can move freely on a smooth horizontal surface. The inclination of the face PR to the horizontal is  $45^\circ$ . Then :

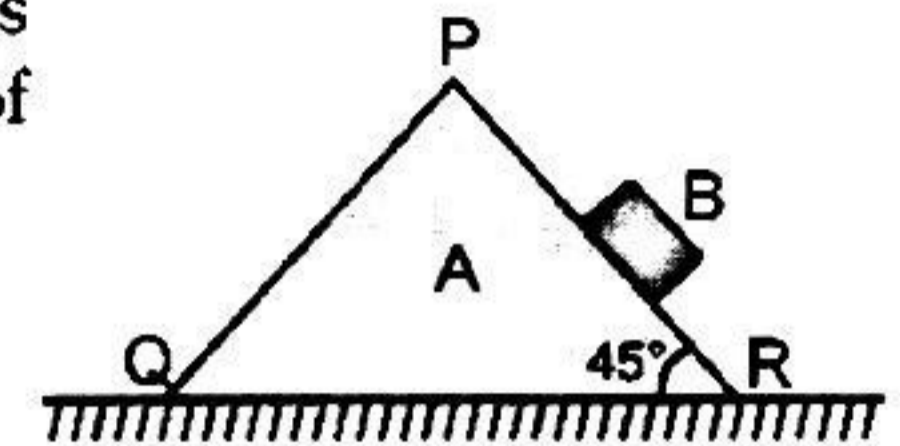

- (A) the acceleration of A is  $3g/20$   
 (B) the vertical component of the acceleration of B is  $23g/40$   
 (C) the horizontal component of the acceleration of B is  $17g/40$   
 (D) none of these

## ANSWERS

### EXERCISE-2

Que.	1	2	3	4	5	6	7	8	9	10
Ans.	A,B,C,D	B,D	A,C	A,B,C	C,D	A,C	A	A,C	A,C	A,B
Que.	11	12	13	14						
Ans.	A,B,D	A,B,C,D	A,B	A,B,C						

## EXERCISE-03

## MISCELLANEOUS TYPE QUESTIONS

### True / False

- The pulley arrangements of figure (a) and (b) are identical. The mass of the rope is negligible. In (a) the mass  $m$  is lifted up by attaching a mass  $2m$  to the other end of the rope. In (b),  $m$  is lifted up by pulling the other end of the rope with a constant downward force  $F = 2mg$ . The acceleration of  $m$  is the same in both cases.

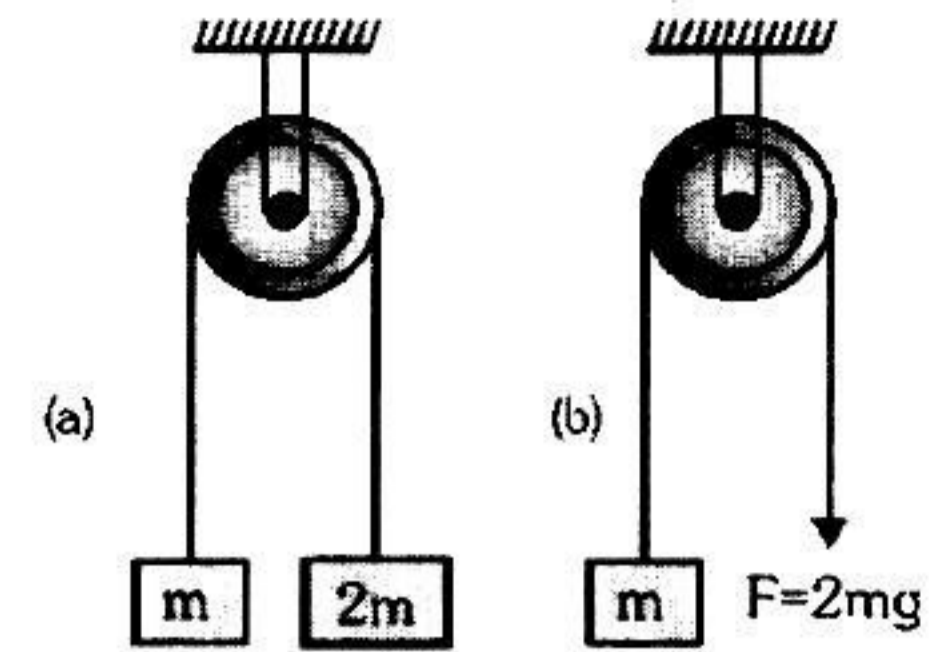

- A car with closed windows makes a left turn. A helium filled balloon in the car will be pushed to the left side.

### Fill in the blanks

- A uniform rod of length  $L$  & density  $\rho$  is being pulled along a smooth floor with a horizontal acceleration  $\alpha$  (see figure) The magnitude of the stress (force/area) at the transverse cross-section through the mid-point of the rod is .....

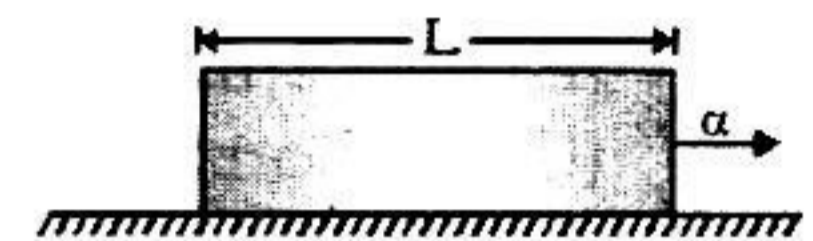

### Match the column

- In the diagram shown in figure ( $g = 10 \text{ m/s}^2$ )

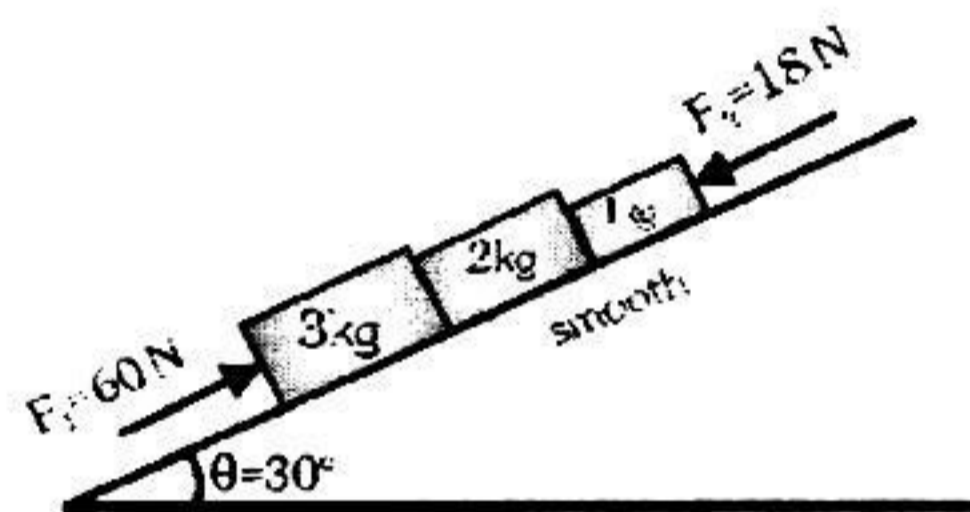

#### Column I

- (A) Acceleration of 2kg block
- (B) Net force on 3kg block
- (C) Normal reaction between 2kg and 1kg
- (D) Normal reaction between 3kg and 2kg

#### Column II

- (p) 8 SI unit
- (q) 25 SI unit
- (r) 2 SI unit
- (s) 39 N
- (t) 6 N

- Velocity of three particles A, B and C varies with time  $t$  as,  $\vec{v}_A = (2t\vec{i} + 6t\vec{j}) \text{ m/s}$ ,  $\vec{v}_B = (3\vec{i} + 4\vec{j}) \text{ m/s}$  and  $\vec{v}_C = (6\vec{i} - 4t\vec{j}) \text{ m/s}$ . Regarding the pseudo force match the following table :

#### Column I

- (A) On A as observed by B
- (B) On B as observed by C
- (C) On A as observed by C
- (D) On C as observed by A

#### Column II

- (p) Along positive  $x$ -direction
- (q) Along negative  $x$ -direction
- (r) Along positive  $y$ -direction
- (s) Along negative  $y$ -direction
- (t) Zero

### Assertion & Reason

- Statement-I** : A stationary object placed on ground may experience a pseudo force as observed by the reference frame attached to the ground.

**because**

**Statement-II** : Earth (a rotating body) is a non-inertial frame.

  - (A) Statement-I is true, Statement-II is true ; Statement-II is correct explanation for Statement-I.
  - (B) Statement-I is true, Statement-II is true ; Statement-II is NOT a correct explanation for statement-I
  - (C) Statement-I is true, Statement-II is false
  - (D) Statement-I is false, Statement-II is true

2. **Statement-I** : A man who falls from a height on a cement floor receive more injury than when he falls from the same height on a heap of sand.  
**because**  
**Statement-II** : The impulse applied by a cement floor is more than the impulse by sand floor.  
 (A) Statement-I is true, Statement-II is true ; Statement-II is correct explanation for Statement-I.  
 (B) Statement-I is true, Statement-II is true ; Statement-II is NOT a correct explanation for statement-I  
 (C) Statement-I is true, Statement-II is false  
 (D) Statement-I is false, Statement-II is true
3. **Statement-I** : In Karate a brick is broken with a bare hand.  
**because**  
**Statement-II** : In this process the impulse is sharp.  
 (A) Statement-I is true, Statement-II is true ; Statement-II is correct explanation for Statement-I.  
 (B) Statement-I is true, Statement-II is true ; Statement-II is NOT a correct explanation for statement-I  
 (C) Statement-I is true, Statement-II is false  
 (D) Statement-I is false, Statement-II is true
4. **Statement-I** : Aeroplanes always fly at low altitudes.  
**because**  
**Statement-II** : According to Newton's third law of motion, for every action there is an equal and opposite reaction.  
 (A) Statement-I is true, Statement-II is true ; Statement-II is correct explanation for Statement-I.  
 (B) Statement-I is true, Statement-II is true ; Statement-II is NOT a correct explanation for statement-I  
 (C) Statement-I is true, Statement-II is false  
 (D) Statement-I is false, Statement-II is true
5. **Statement-I** : Two teams having a tug of war always pull equally hard on one another.  
**because**  
**Statement-II** : The team that pushes harder against the ground, in a tug of war, wins.  
 (A) Statement-I is true, Statement-II is true ; Statement-II is correct explanation for Statement-I.  
 (B) Statement-I is true, Statement-II is true ; Statement-II is NOT a correct explanation for statement-I  
 (C) Statement-I is true, Statement-II is false  
 (D) Statement-I is false, Statement-II is true

### Comprehension Based Questions

#### Comprehension 1

If three concurrent forces  $\vec{F}_1$ ,  $\vec{F}_2$  and  $\vec{F}_3$  are in equilibrium then according to Lami's

theorem. 
$$\frac{F_1}{\sin \alpha} = \frac{F_2}{\sin \beta} = \frac{F_3}{\sin \gamma}$$

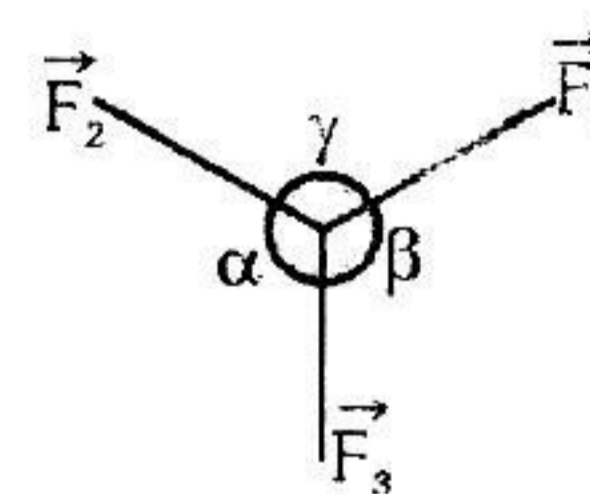

1. One end of a string 0.5 m long is fixed to a point A and other end is fastened to a small object of weight 8N. The object is pulled aside by a horizontal force F, until it is 0.3 m from the vertical through A. The magnitude of the tension T in the string and the force F will be  
 (A) 6N, 10N (B) 10N, 6N  
 (C) 8N, 10N (D) 3N, 4N

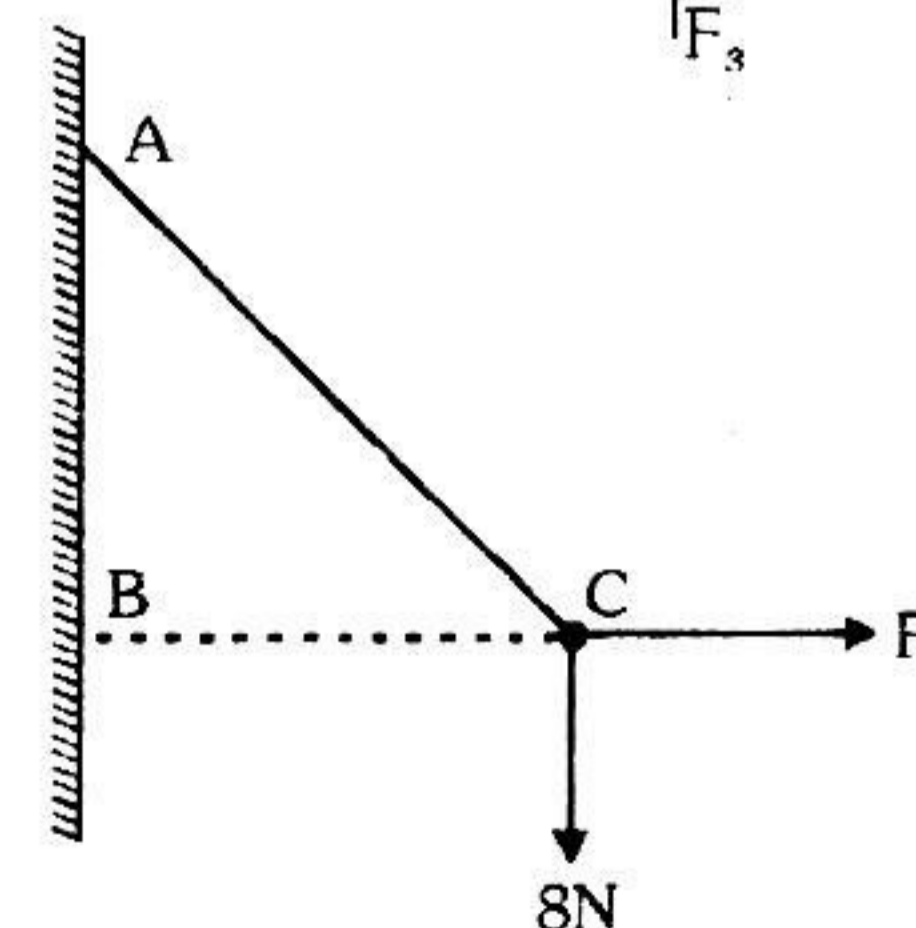

2. A solid sphere of mass 10 kg is placed over two smooth inclined planes as shown in figure. Normal reaction at 1 and 2 will be : ( $g = 10 \text{ m/s}^2$ )  
 (A)  $50\sqrt{3}\text{N}, 50\text{N}$  (B) 50N, 50N  
 (C) 50N,  $50\sqrt{3}\text{N}$  (D) 60N, 40N

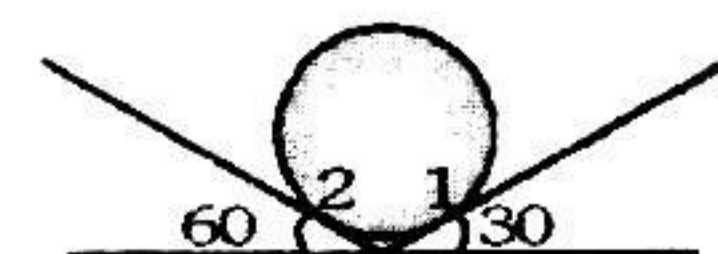

### Comprehension 2

A rod of length  $\ell (< 2R)$  is kept horizontally inside a smooth spherical shell as shown in figure. Mass of the rod is  $m$ .

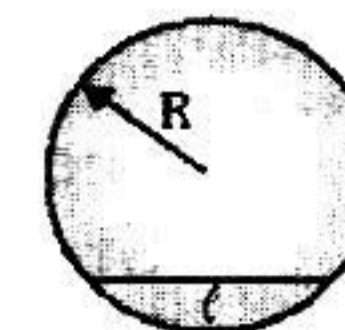

- Keeping mass to be constant if length of the rod is increased (but always  $< 2R$ ) the normal reactions at two ends of the rod.  
 (A) Will remain constant (B) Will increase (C) Will decrease (D) May increase or decrease
- The normal reaction when  $\ell = R$  is :-  
 (A)  $\frac{mg}{2}$  (B)  $\frac{mg}{4}$  (C)  $\frac{mg}{2\sqrt{3}}$  (D)  $\frac{mg}{\sqrt{3}}$

### Comprehension 3

Two smooth blocks are placed at a smooth corner as shown. Both the blocks are having mass  $m$ . We apply a force  $F$  on the block A. Block A presses the block B in the normal direction, due to which pressing force on vertical wall will increase, and pressing force on the horizontal wall decrease, as we increase  $F$ . As soon as the pressing force on the horizontal by block B becomes zero, it will loose the contact with the ground. If the value of  $F$  is further increased, the block B will accelerate in upward direction and simultaneously the block A will move toward right ( $\theta = 37^\circ$  with horizontal).

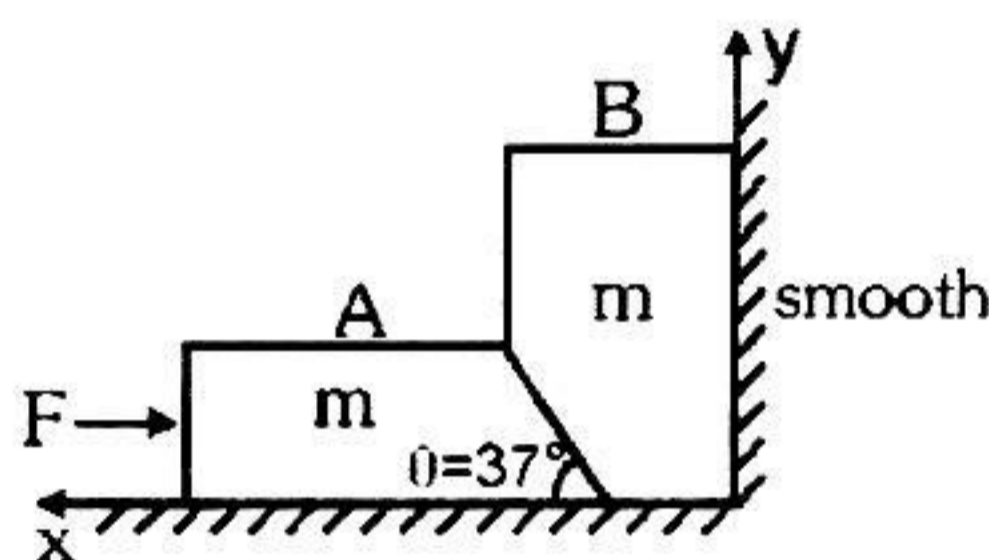

- What is minimum value of  $F$ , to lift block B from ground ?  
 (A)  $\frac{25}{12} mg$  (B)  $\frac{5}{4} mg$  (C)  $\frac{3}{4} mg$  (D)  $\frac{4}{3} mg$
- If both the blocks are stationary, the force exerted by ground on block A is :  
 (A)  $mg + \frac{3F}{4}$  (B)  $mg - \frac{3F}{4}$  (C)  $mg + \frac{4F}{3}$  (D)  $mg - \frac{4F}{3}$
- If acceleration of block A is a rightward, then acceleration of block B will be :  
 (A)  $\frac{3a}{4}$  upwards (B)  $\frac{4a}{3}$  upwards (C)  $\frac{3a}{5}$  upwards (D)  $\frac{4a}{5}$  upwards

### Comprehension 4

Figure shows a weighing machine kept in a lift. Lift is moving upwards with acceleration of  $5 \text{ m/s}^2$ . A block is kept on the weighing machine. Upper surface of block is attached with a spring balance. Reading shown by weighing machine and spring balance is  $15 \text{ kg}$  and  $45 \text{ kg}$  respectively.

Answer the following questions. Assume that the weighing machine can measure weight by having negligible deformation due to block, while the spring balance requires larger expansion : (take  $g = 10 \text{ m/s}^2$ )

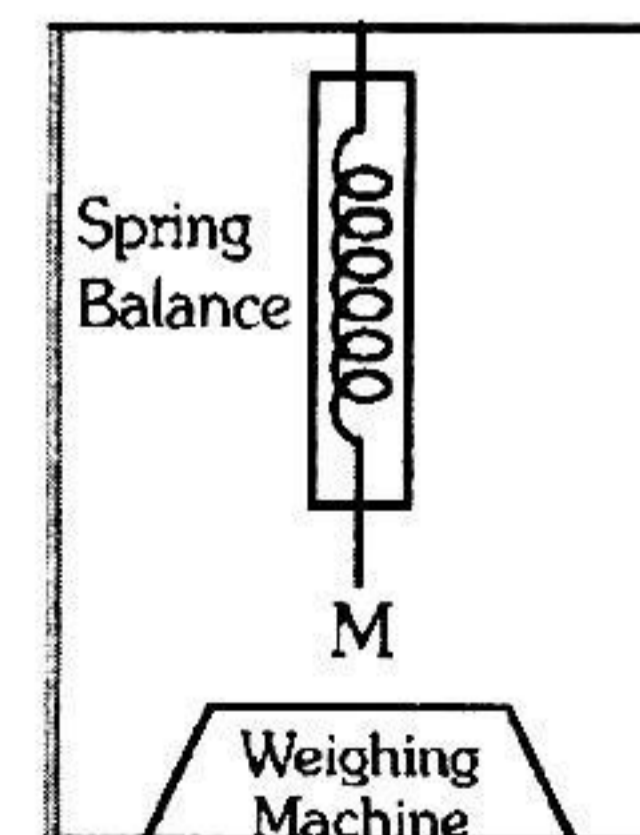

- Mass of the object in kg is :  
 (A)  $60 \text{ kg}$  (B)  $40 \text{ kg}$  (C)  $80 \text{ kg}$  (D)  $10 \text{ kg}$
- In the above situation normal acting on the block as seen by an observer in the lift.  
 (A)  $450 \text{ N}$  (B)  $150 \text{ N}$  (C)  $400 \text{ N}$  (D) zero

3. If lift is stopped and equilibrium is reached. Reading of weighing machine will be :  
 (A) 40 kg (B) 10 kg (C) 20 kg (D) zero
4. If lift is stopped and equilibrium is again reached. Reading of spring balance will be :  
 (A) zero (B) 20 kg (C) 10 kg (D) 40 kg
5. Find the acceleration of the lift such that the weighing machine shows its true weight.  
 (A)  $\frac{45}{4} \text{ m/s}^2$  (B)  $\frac{85}{4} \text{ m/s}^2$  (C)  $\frac{11}{2} \text{ m/s}^2$  (D)  $15 \text{ m/s}^2$

### Comprehension 5

Two blocks A and B of equal masses  $m$  kg each are connected by a light thread, which passes over a massless pulley as shown. Both the blocks lie on wedge of mass  $m$  kg. Assume friction to be absent everywhere and both the blocks to be always in contact with the wedge. The wedge lying over smooth horizontal surface is pulled towards right with constant acceleration  $a$  ( $\text{m/s}^2$ ). ( $g$  is acceleration due to gravity).

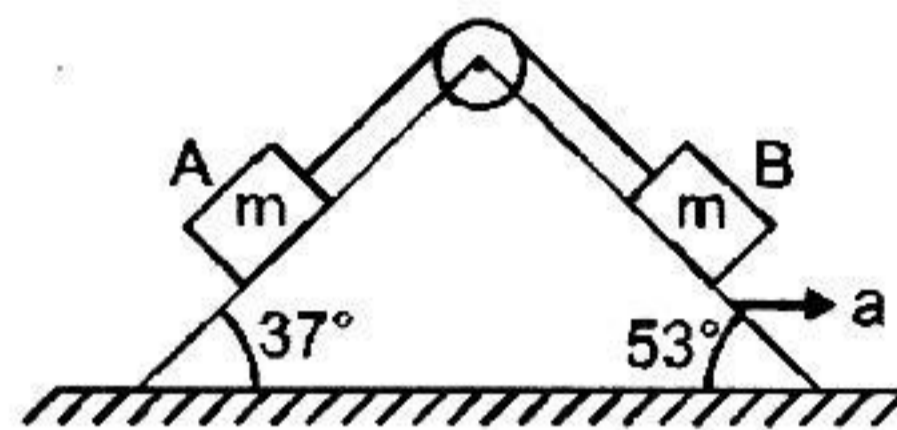

1. Normal reaction (in N) acting on block B is  
 (A)  $\frac{m}{5} (3g + 4a)$  (B)  $\frac{m}{5} (3g - 4a)$  (C)  $\frac{m}{5} (4g + 3a)$  (D)  $\frac{m}{5} (4g - 3a)$
2. Normal reaction (in N) acting on block A.  
 (A)  $\frac{m}{5} (3g + 4a)$  (B)  $\frac{m}{5} (3g - 4a)$  (C)  $\frac{m}{5} (4g + 3a)$  (D)  $\frac{m}{5} (4g - 3a)$
3. The maximum value of acceleration  $a$  (in  $\text{m/s}^2$ ) for which normal reactions acting on the block A and block B are nonzero.  
 (A)  $\frac{3}{4}g$  (B)  $\frac{4}{3}g$  (C)  $\frac{3}{5}g$  (D)  $\frac{5}{3}g$

## ANSWERS

### EXERCISE-3

- **True / False**                      1. F                      2. T
- **Fill in the blanks :**              1.  $\frac{\rho L \alpha}{2}$
- **Match the column :**            1. (A) r, (B) t, (C) q, (D) s                      2. (A) t, (B) r, (C) r, (D) q
- **Assertion & Reason :**    1. A                      2. C                      3. A                      4. A                      5. B
- **Comprehension based Questions :**
  - Comprehension-1**    1. B                      2. A
  - Comprehension-2.**    1. B                      2. D
  - Comprehension-3**    1. C                      2. C                      3. A
  - Comprehension-4**    1. B                      2. B                      3. D                      4. D                      5. A
  - Comprehension-5**    1. A                      2. D                      3. B

## EXERCISE-04 [A]

## SUBJECTIVE EXERCISE LEVEL - I

1. A solid sphere of mass 2 kg is resting inside a cube as shown in figure. The cube is moving with a velocity  $\vec{v} = (5t\hat{i} + 2t\hat{j})$  m/sec. Here  $t$  is the time in second. All surface are smooth. The sphere is at rest with respect to the cube. What is the total force exerted by the sphere on the cube? (Take  $g = 10 \text{ ms}^{-2}$ )

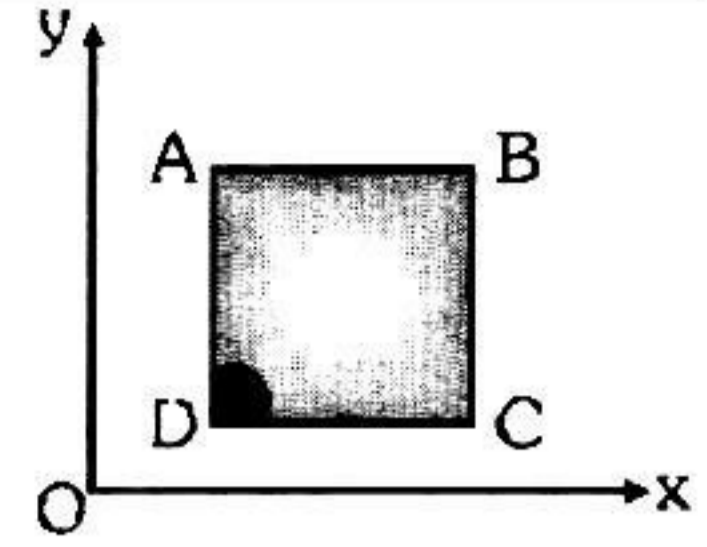

2. If contact force between 2kg and 4kg is  $f_1$  and between 4kg and 6 kg is  $f_2$ . Find out  $f_1$  and  $f_2$ .

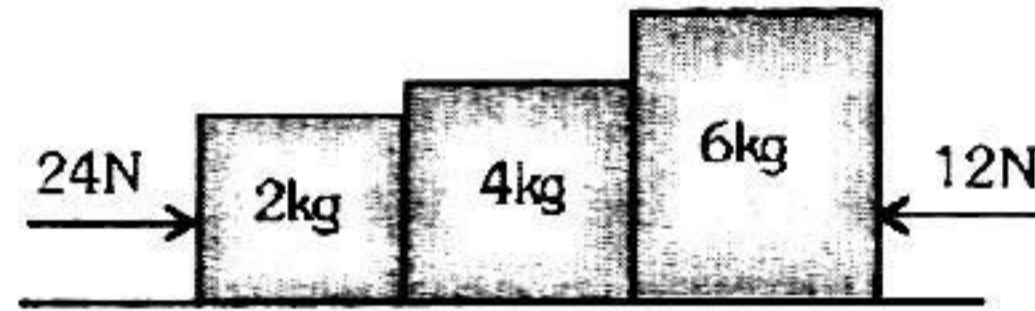

3. Fig. shows a bead of mass  $m$  moving with uniform speed  $v$  through a U-shaped smooth wire the wire has a semicircular bending between A and B. Calculate The average force exerted by the bead on the part AB of the wire.

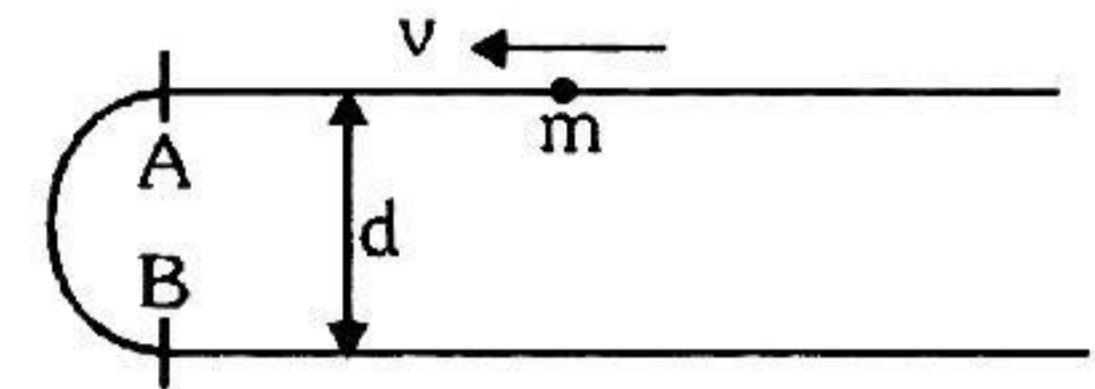

4. A monkey of mass 40 kg climbs on a rope which can stand a maximum tension of 600 N. Calculate tension in rope in following cases. In which case will the rope break :  
 (i) The monkey climbs up with an acceleration of  $6 \text{ m s}^{-2}$ .  
 (ii) The monkey climbs down with an acceleration of  $4 \text{ m s}^{-2}$ .  
 (iii) The monkey climbs up with a uniform speed of  $5 \text{ m s}^{-1}$ . Neglect the mass of string. ( $g = 9.8 \text{ ms}^{-2}$ )

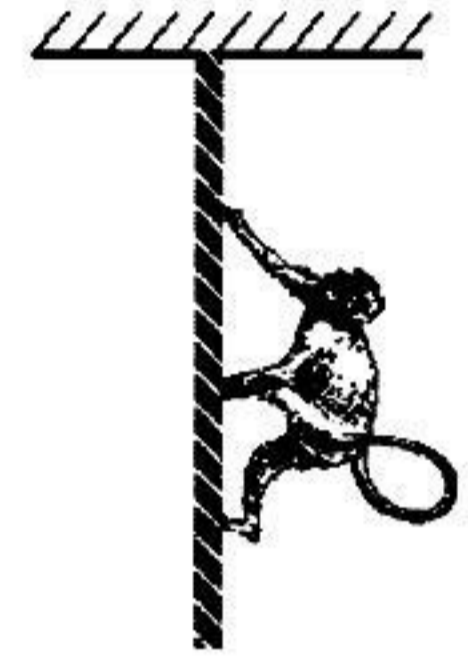

5. A dynamometer is attached to two blocks of masses 6 kg and 4 kg. Forces of 20 N and 10 N are applied on the blocks as shown in figure. Find the dynamometer reading.

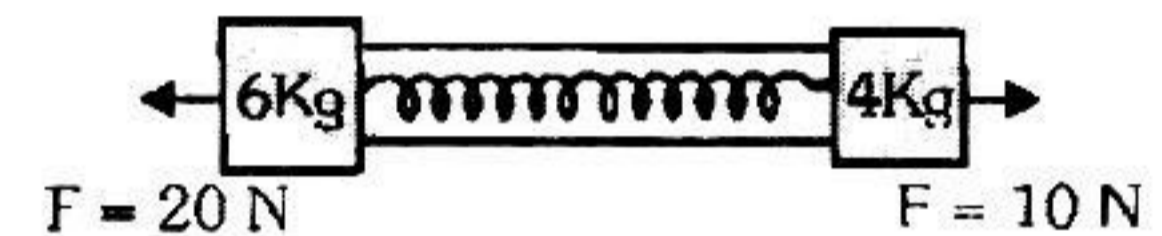

6. Two block of mass 8 kg and 4kg are connected by a string as shown. Calculate their acceleration if they are initially at rest on the floor, when a force of 100N is applied on the pulley in upward direction ( $g = 10\text{ms}^{-2}$ )

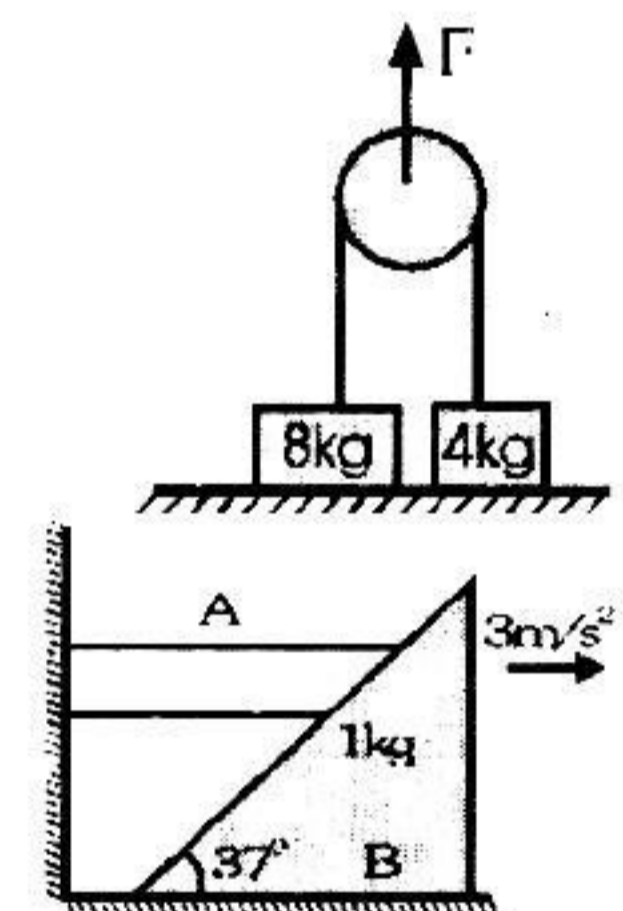

7. Find force in newton which mass A exerts on mass B if B is moving towards right with  $3 \text{ ms}^{-2}$ . All surfaces are smooth and  $g=10\text{m/s}^2$ .

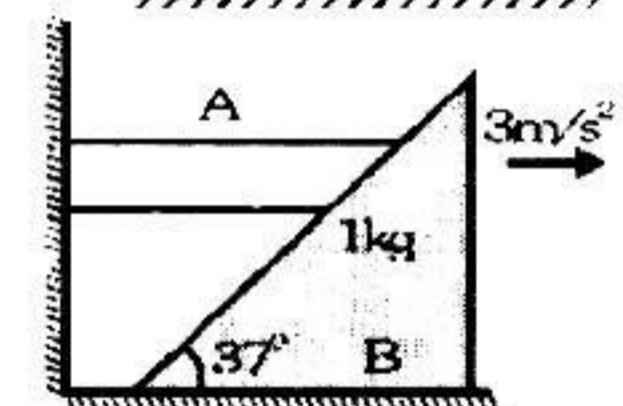

8. A painter of mass  $M$  stand on a platform of mass  $m$  and pulls himself up by two ropes which hang over pulley as shown. He pulls each rope with the force  $F$  and moves upward with uniform acceleration 'a'. Find 'a' (neglecting the fact that no one could do this for long time).

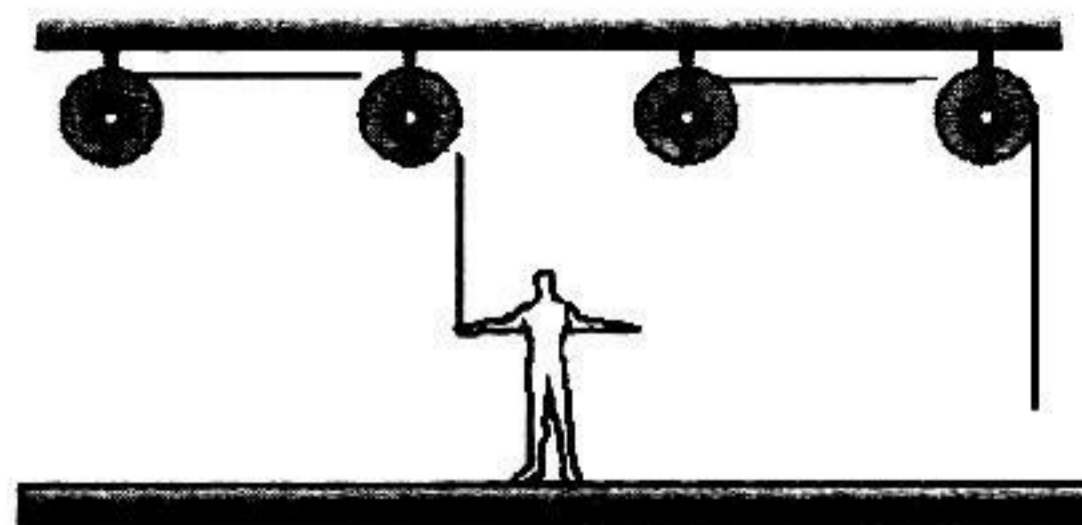

9. Three monkeys A, B and C with masses of 10 , 15 & 8 Kg respectively are climbing up & down the rope suspended from D . At the instant represented , A is descending the rope with an acceleration of  $2 \text{ m/s}^2$  & C is pulling himself up with an acceleration of  $1.5 \text{ m/s}^2$  . Monkeys B is climbing up with a constant speed of  $0.8 \text{ m/s}$  . Treat the rope and monkeys as a complete system & calculate the tension  $T$  in the rope at D . ( $g = 10 \text{ m/s}^{-2}$  )

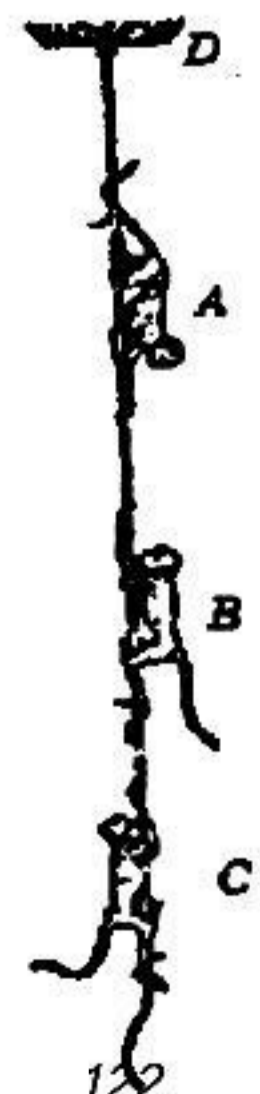

10. The masses of blocks A and B are same and equal to  $m$ . Friction is absent everywhere. Find the magnitude of normal force with which block B presses on the wall and accelerations of the blocks A and B.

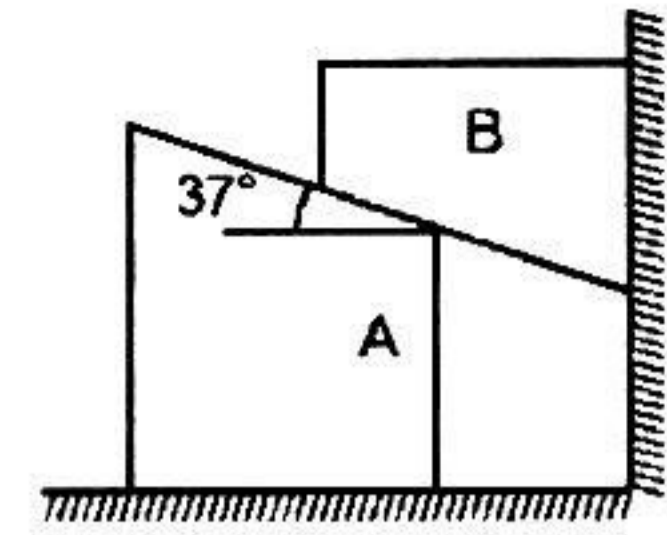

11. The block C shown in the figure is ascending with an acceleration  $a = 3 \text{ m/s}^2$  by means of some motor not shown here. Find the acceleration of the bodies A and B of masses 10 kg and 5 kg, respectively, assuming that pulleys are massless and friction is absent everywhere.

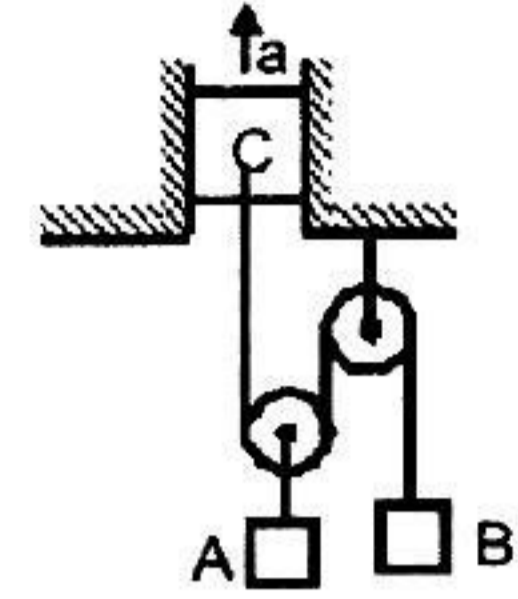

12. In arrangement shown in the figure, find the acceleration of M. The pulleys are light. The strings are massless. Neglect the dimension of pulleys and masses.

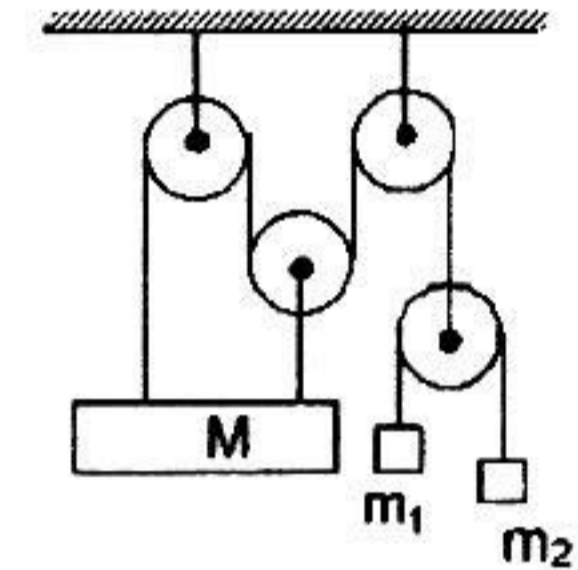

13. A force  $F$  is applied on block A of mass  $M$  so that the tension in light string also becomes  $F$  when block B of mass  $m$  acquires an equilibrium state with respect to block A. Find the force  $F$ . Give your answer in terms of  $m$ ,  $M$  and  $g$ .

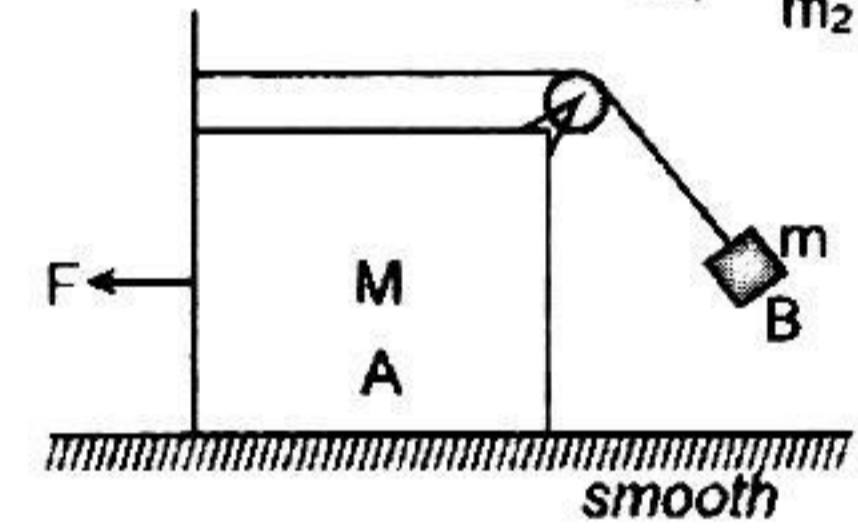

14. Three identical balls 1,2,3 are suspended on springs one below the other as shown in the figure. OA is a weightless thread.  
 (a) If the thread is cut, the system starts falling. Find the acceleration of all the balls at the initial instant  
 (b) Find the initial accelerations of all the balls if we cut the spring BC which is supporting ball 3 instead of cutting the thread.

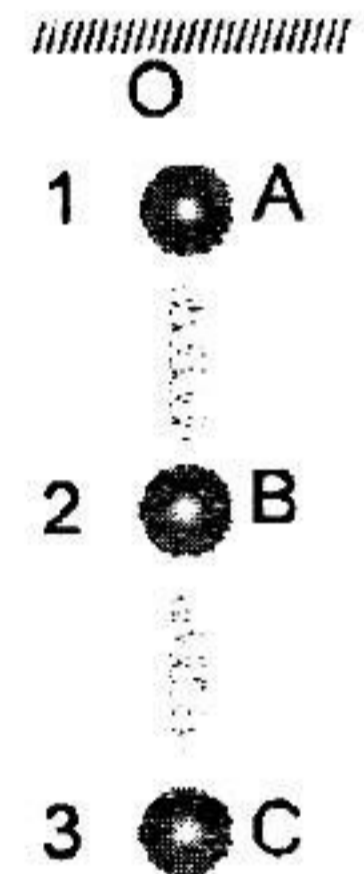

15. A block B is placed over a cart which in turn lies over a smooth horizontal floor. Block A and block C are connected to block B with light inextensible strings passing over light frictionless pulleys fixed to the cart as shown. Initially the blocks and the cart are at rest. All the three blocks have mass  $m$  and the cart has mass  $M(M = 3m)$ . Now a constant horizontal force of magnitude  $F$  is applied to block A towards right. (Assuming friction to be absent everywhere)

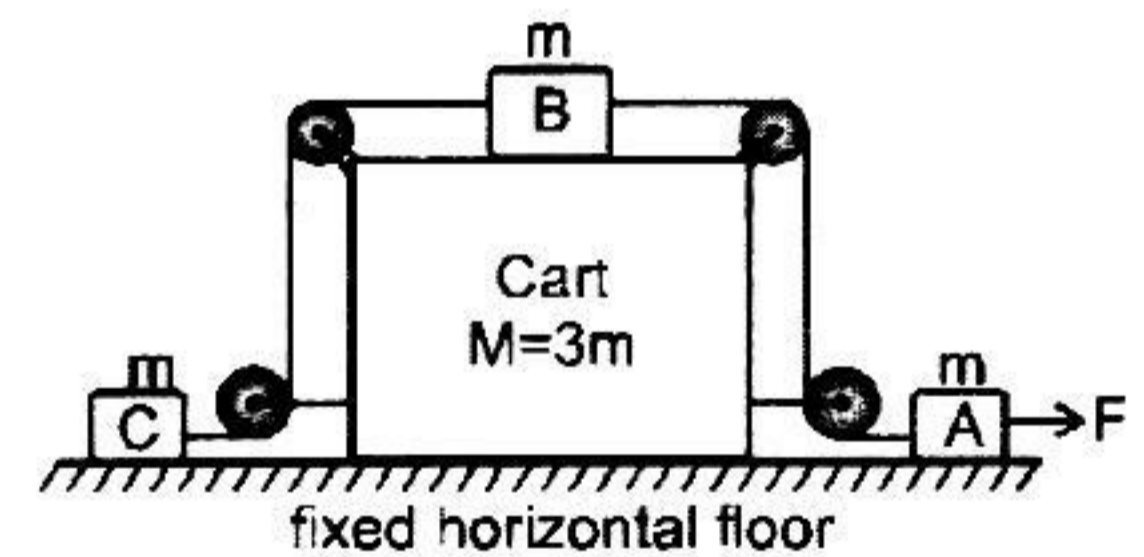

- (a) Find the magnitude of acceleration of cart at the shown instant.  
 (b) Find the magnitude of tension in the string connecting block B and block C.

16. A small block of mass 1kg starts moving with constant velocity 18 m/sec on smooth long plank of mass 10 kg which is also pulled by a horizontal force  $F = 20t^2 \text{ N}$ , where  $t$  is in seconds and  $F$  is in newtons (Initial velocity of the plank is zero)

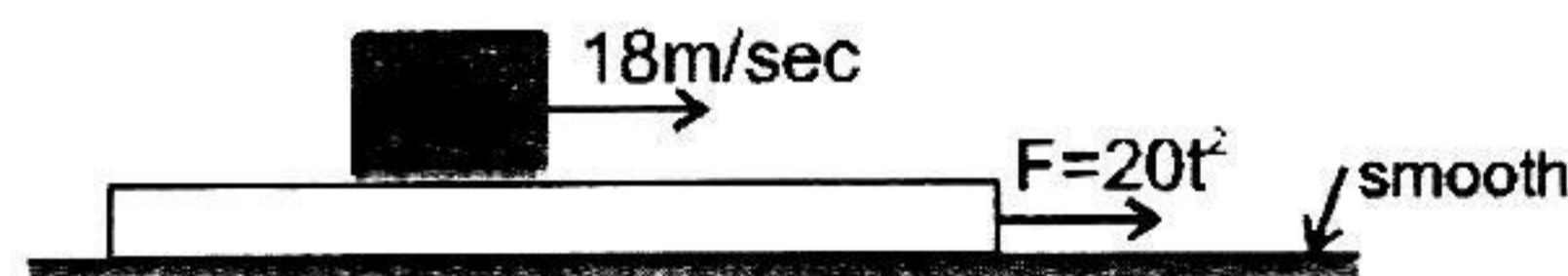

- (a) Find the displacement of 1 kg block with respect to the plank at the instant when both have the same velocity.  
 (b) Find the magnitude of displacement of block with respect to plank when acceleration of plank is  $4 \text{ m/s}^2$ .

# ANSWERS

## EXERCISE-4(A)

1.  $(-10\vec{i} - 24\vec{j}) \text{ N}$

4. (i)

7. 5N

10.  $a = \frac{12g}{25}$ ;  $b = \frac{9g}{25}$ ;  $N_{BW} = \frac{12mg}{25}$ .

12.  $g \left[ 1 - \frac{48}{\frac{M}{m_1} + \frac{M}{m_2} + 36} \right] \downarrow$

14: (a)  $3g \downarrow, 0, 0$ , (b)  $0, g \uparrow, g \downarrow$

15. (a) 0 (b)  $\frac{F}{3}$

2. 22N, 18N

5. 14 N

8.  $a = \frac{4F}{M+m} - g$ .

3.  $\frac{4mv^2}{\pi d}$

6. For 4 kg  $a = 2.5 \text{ ms}^{-2}$ . For 8 kg  $a=0$

9. 322 N

11.  $a_A = a_B = 1 \text{ m/s}^2$  upward

13.  $F = \frac{mg}{\sqrt{1 - \left(\frac{m}{m+M}\right)^2}}$

16. (a)  $\frac{81}{2} \text{ m}$  (b)  $2 \left[ 9\sqrt{2} - \frac{1}{3} \right] \text{ m}$

**EXERCISE-05 [A]****RECAP OF AIEEE/JEE (MAIN)**

1. When forces  $F_1, F_2, F_3$  are acting on a particle of mass  $m$  such that  $F_2$  and  $F_3$  are mutually perpendicular, then the particle remains stationary. If the force  $F_1$  is now removed then the acceleration of the particle is- [AIEEE - 2002]  
 (1)  $F_1/m$  (2)  $F_2F_3/mF_1$  (3)  $(F_2 - F_3)/m$  (4)  $F_2/m$

2. Three identical blocks of masses  $m = 2$  kg are drawn by a force  $F$  with an acceleration of  $0.6 \text{ ms}^{-2}$  on a frictionless surface, then what is the tension (in N) in the string between the blocks B and C [AIEEE - 2002]

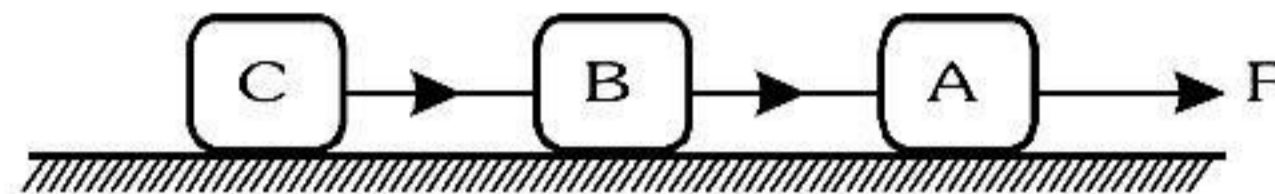

- (1) 9.2 (2) 1.2 (3) 4 (4) 9.8

3. One end of massless rope, which passes over a massless and frictionless pulley P is tied to a hook C while the other end is free. Maximum tension that the rope can bear is 840 N. With what value of maximum safe acceleration (in  $\text{ms}^{-2}$ ) can a man of 60 kg climb on the rope? [AIEEE - 2002]  
 (1) 16 (2) 6  
 (3) 4 (4) 8

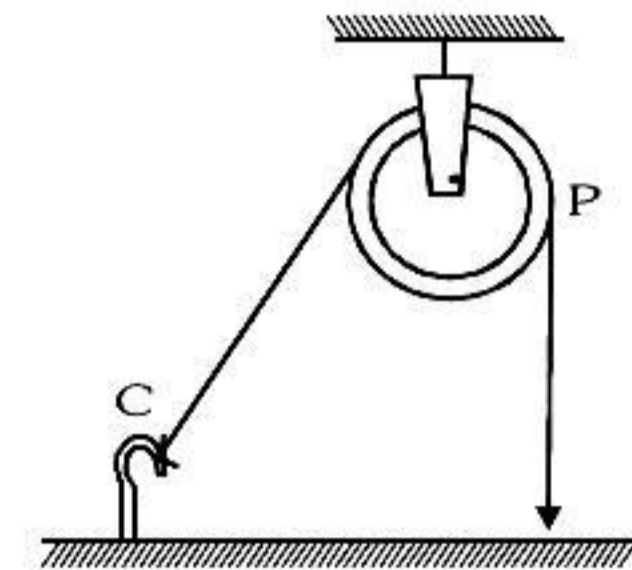

4. A light spring balance hangs from the hook of the other light spring balance and a block of mass  $M$  kg hangs from the former one. Then the true statement about the scale reading is- [AIEEE - 2003]  
 (1) both the scales read  $M$  kg each  
 (2) the scale of the lower one reads  $M$  kg and of the upper one zero  
 (3) The reading of the two scales can be anything but the sum of the readings will be  $M$  kg  
 (4) both the scales read  $M/2$  kg

5. A spring balance is attached to the ceiling of a lift. A man hangs his bag on the spring and the spring reads 49 N, when the lift is stationary. If the lift moves downward with an acceleration of  $5 \text{ m/s}^2$ , the reading of the spring balance will be- [AIEEE - 2003]  
 (1) 24 N (2) 74 N (3) 15 N (4) 49 N

6. A rocket which has a mass of  $3.5 \times 10^4$  kg is blasted upwards with an initial acceleration of  $10 \text{ m/s}^2$ . Then the initial thrust of the blast is- [AIEEE - 2003]  
 (1)  $3.5 \times 10^5$  N (2)  $7.0 \times 10^5$  N (3)  $14.0 \times 10^5$  N (4)  $1.75 \times 10^5$  N

7. Three forces start acting simultaneously on a particle moving with velocity  $\vec{v}$ . These forces are represented in magnitude and direction by the three sides of a triangle ABC (as shown). The particle will now move with velocity- [AIEEE - 2003]

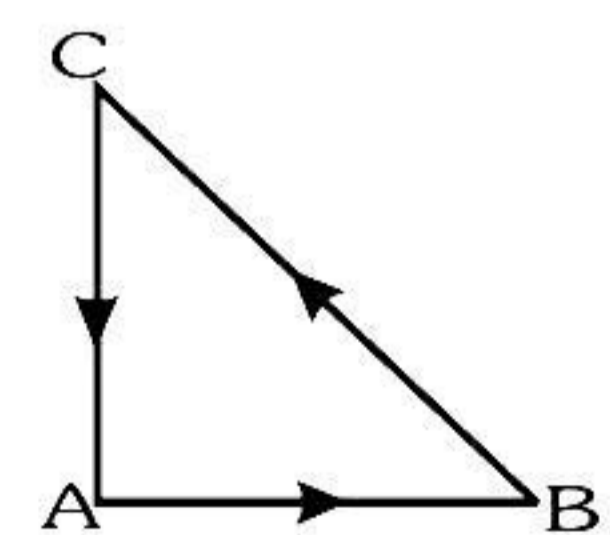

- (1) Less than  $\vec{v}$  (2) greater than  $\vec{v}$   
 (3)  $|\vec{v}|$  in the direction of largest force BC (4)  $\vec{v}$ , remaining unchanged

8. A block of mass  $M$  is pulled along a horizontal frictionless surface by a rope of mass  $m$ . If a force  $P$  is applied at the free end of the rope, the force exerted by the rope on the block is-[AIEEE - 2003]  
 (1)  $\frac{Pm}{M+m}$  (2)  $\frac{Pm}{M-m}$  (3)  $P$  (4)  $\frac{PM}{M+m}$

9. Two masses  $m_1 = 5 \text{ kg}$  and  $m_2 = 4.8 \text{ kg}$  tied to a string are hanging over a light frictionless pulley. What is the acceleration of the masses when they are free to move ? ( $g = 9.8 \text{ m/s}^2$ ) [AIEEE - 2004]

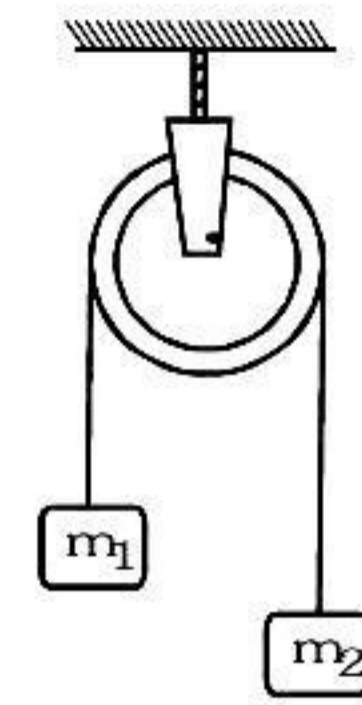

- (1)  $0.2 \text{ m/s}^2$  (2)  $9.8 \text{ m/s}^2$   
 (3)  $5 \text{ m/s}^2$  (4)  $4.8 \text{ m/s}^2$

10. A machine gun fires a bullet of mass  $40 \text{ g}$  with a velocity  $1200 \text{ ms}^{-1}$ . The man holding it, can exert maximum force of  $144 \text{ N}$  on the gun. How many bullets can he fire per second at the most? [AIEEE - 2004]
- (1) One (2) Four (3) Two (4) Three

11. A block is kept on a frictionless inclined surface with angle of inclination  $\alpha$ . The incline is given an acceleration  $a$  to keep the block stationary. Then  $a$  is equal to- [AIEEE - 2005]

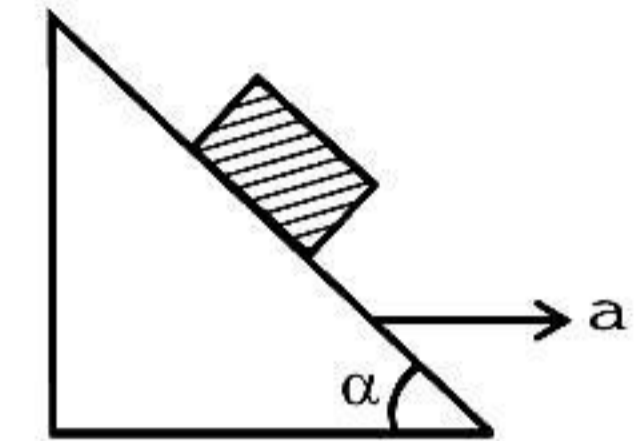

- (1)  $g/\tan\alpha$  (2)  $g \operatorname{cosec}\alpha$   
 (3)  $g$  (4)  $g \tan\alpha$

12. A player caught a cricket ball of mass  $150 \text{ g}$  moving at a rate of  $20 \text{ m/s}$ . If the catching process is completed in  $0.1 \text{ s}$ ., the force of the blow exerted by the ball on the hand of the player is equal to- [AIEEE - 2006]
- (1)  $150 \text{ N}$  (2)  $3 \text{ N}$  (3)  $30 \text{ N}$  (4)  $300 \text{ N}$

13. A block of mass  $m$  is connected to another block of mass  $M$  by a spring (massless) of spring constant  $k$ . The blocks are kept on a smooth horizontal plane. Initially the blocks are at rest and the spring is unstretched. Then a constant force  $F$  starts acting on the block of mass  $M$  to pull it. Find the force on the block of mass  $m$  :- [AIEEE - 2007]

- (1)  $\frac{mF}{M}$  (2)  $\frac{(M+m)F}{m}$  (3)  $\frac{mF}{(m+M)}$  (4)  $\frac{MF}{(m+M)}$

14. Two fixed frictionless inclined planes making an angle  $30^\circ$  and  $60^\circ$  with the vertical are shown in the figure. Two blocks A and B are placed on the two planes. What is the relative vertical acceleration of A with respect to B? [AIEEE - 2010]

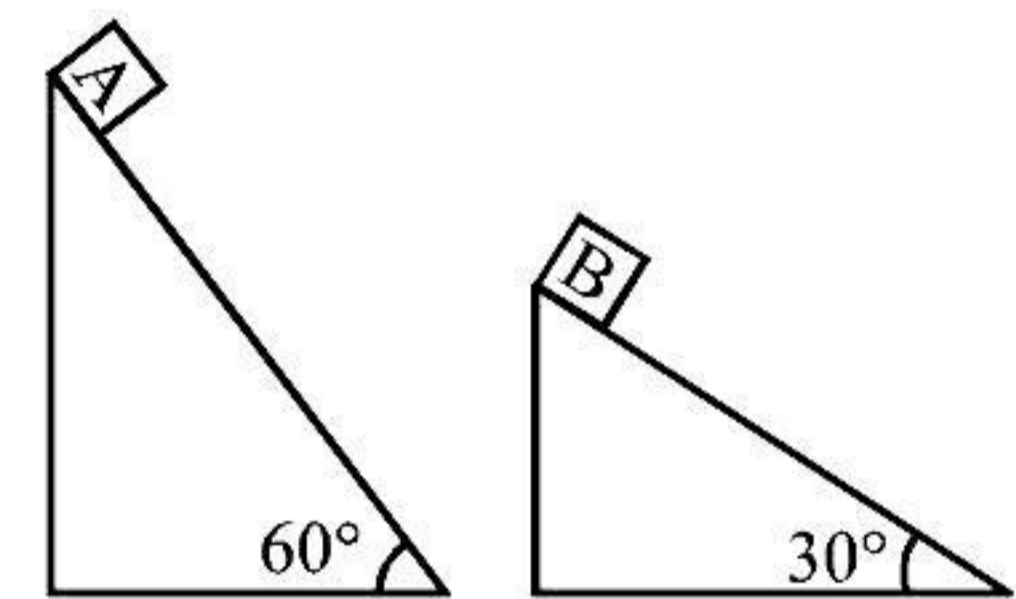

- (1)  $4.9 \text{ ms}^{-2}$  in vertical direction.  
 (2)  $4.9 \text{ ms}^{-2}$  in horizontal direction  
 (3)  $9.8 \text{ ms}^{-2}$  in vertical direction  
 (4) Zero

15. A particle of mass  $m$  is at rest at the origin at time  $t = 0$ . It is subjected to a force  $F(t) = F_0 e^{-bt}$  in the  $x$ -direction. Its speed  $v(t)$  is depicted by which of the following curves ? [AIEEE - 2012]

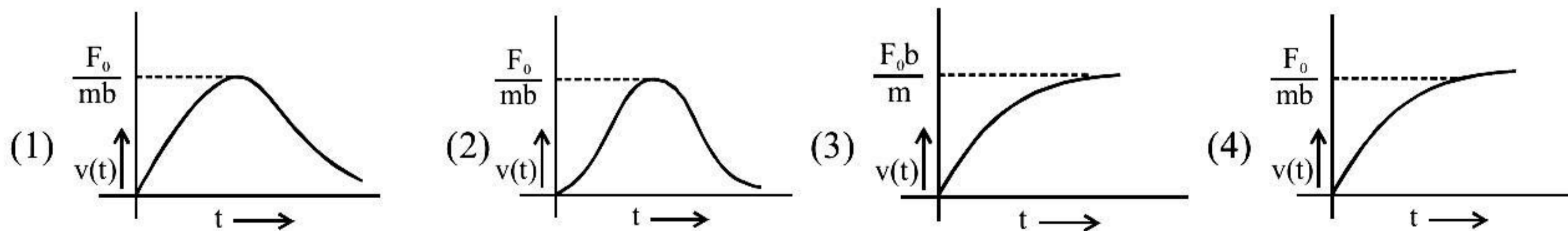

16. Two blocks of mass  $M_1 = 20 \text{ kg}$  and  $M_2 = 12 \text{ kg}$  are connected by a metal rod of mass  $8 \text{ kg}$ . The system is pulled vertically up by applying a force of  $480 \text{ N}$  as shown. The tension at the mid-point of the rod is : [JEE Main (ONLINE)- 2013]

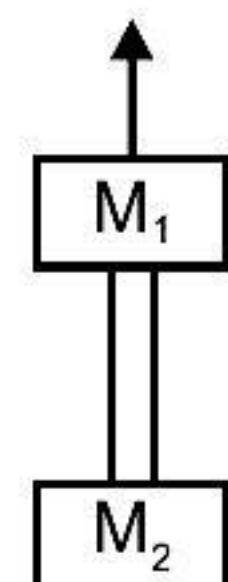

- (1)  $240 \text{ N}$  (2)  $144 \text{ N}$   
 (3)  $96 \text{ N}$  (4)  $192 \text{ N}$

17. A block of mass  $m$  is placed on a surface with a vertical cross-section given by  $y = x^3/6$ . If the coefficient of friction is 0.5, the maximum height above the ground at which the block can be placed without slipping is  
**[JEE Main - 2014]**  
 (1)  $1/6$  m                      (2)  $2/3$  m                      (3)  $1/3$  m                      (4)  $1/2$  m
18. Water is flowing at a speed of  $1.5 \text{ ms}^{-1}$  through a horizontal tube of cross-sectional area  $10^{-2} \text{ m}^2$  and you are trying to stop the flow by your palm. Assuming that the water stops immediately after hitting the palm, the minimum force that you must exert should be (density of water =  $10^3 \text{ kgm}^{-3}$ )  
**[JEE Main (ONLINE)- 2016]**  
 (1) 33.7N                      (2) 15N                      (3) 22.5N                      (4) 45N
19. A particle of mass  $m$  is acted upon by a force  $F$  given by the empirical law  $F = \frac{R}{t^2} v(t)$ . If this law is to be tested experimentally by observing the motion starting from rest, the best way is to plot :  
**[JEE Main (ONLINE)- 2016]**  
 (1)  $\log v(t)$  against  $t$                       (2)  $\log v(t)$  against  $1/t$                       (3)  $\log v(t)$  against  $1/t^2$                       (4)  $v(t)$  against  $t^2$
20. A particle of mass  $m$  is moving in a straight line with momentum  $p$ . Starting at time  $t = 0$ , a force  $F = kt$  acts in the same direction on the moving particle during time interval  $T$  so that its momentum changes from  $p$  to  $3p$ . Here  $k$  is a constant. The value of  $T$  is :-  
**[JEE Main (ONLINE)- 2019]**  
 (1)  $2\sqrt{\frac{p}{k}}$                       (2)  $\sqrt{\frac{2p}{k}}$                       (3)  $\sqrt{\frac{2k}{p}}$                       (4)  $2\sqrt{\frac{k}{p}}$
21. A mass of 10kg is suspended vertically by a rope from the roof. When a horizontal force is applied on the rope at some point, the rope deviated at an angle of  $45^\circ$  at the roof point. If the suspended mass is at equilibrium, the magnitude of the force applied is ( $g = 10 \text{ ms}^{-2}$ )  
**[JEE Main (ONLINE)- 2019]**  
 (1) 200 N                      (2) 100 N                      (3) 140 N                      (4) 70 N

- |         |         |         |         |         |         |         |
|---------|---------|---------|---------|---------|---------|---------|
| 1. (1)  | 2. (2)  | 3. (3)  | 4. (1)  | 5. (1)  | 6. (2)  | 7. (4)  |
| 8. (4)  | 9. (1)  | 10. (4) | 11. (4) | 12. (3) | 13. (3) | 14. (1) |
| 15. (4) | 16. (4) | 17. (1) | 18. (3) | 19. (2) | 20. (1) | 21. (2) |

**EXERCISE-05 [B]****RECAP OF IIT-JEE/JEE (ADVANCED)**

Select the correct alternative (single correct answer)

1. A string of negligible mass going over a clamped pulley of mass  $m$  supports a block of mass  $M$  as shown in the figure. The force on the pulley by the clamp is given by :- **[IIT-JEE 2001]**

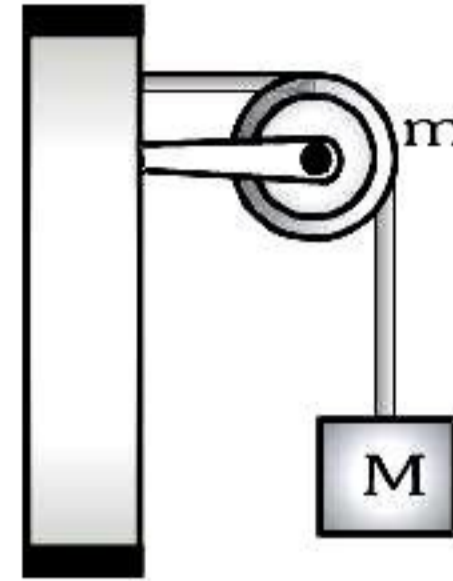

- (A)  $\sqrt{2} Mg$       (B)  $\sqrt{2} mg$       (C)  $\sqrt{(M+m)^2 + m^2}g$       (D)  $\left(\sqrt{(M+m)^2 + M^2}\right)g$
2. The pulleys and strings shown in the figure are smooth and of negligible mass. For the system to remain in equilibrium, the angle  $\theta$  should be :- **[IIT-JEE 2001]**

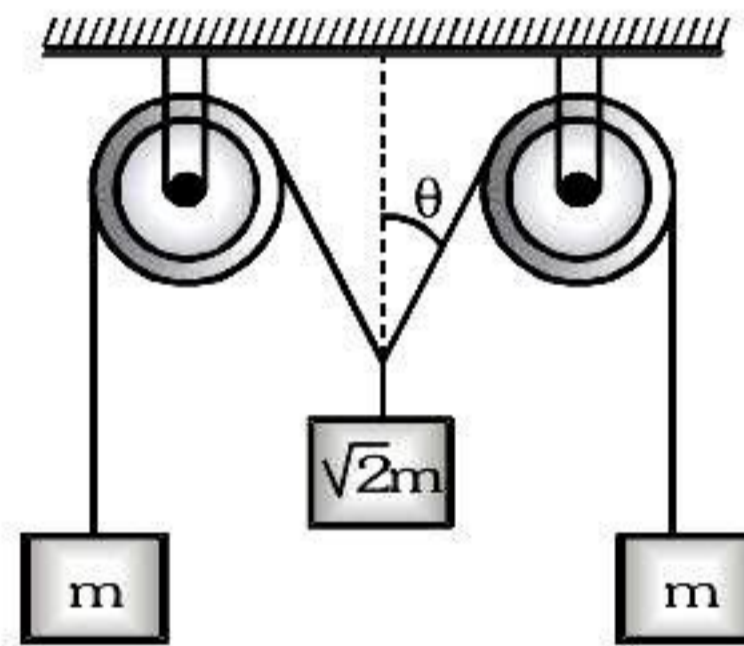

- (A)  $0^\circ$       (B)  $30^\circ$       (C)  $45^\circ$       (D)  $60^\circ$
3. System shown in figure is in equilibrium and at rest. The spring and string are massless, now the string is cut. The acceleration of mass  $2m$  and  $m$  just after the string is cut will be :- **[IIT-JEE 2006]**

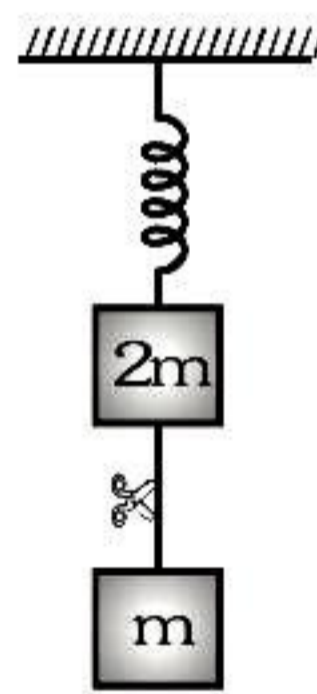

- (A)  $\frac{g}{2}$  upwards,  $g$  downwards      (B)  $g$  upwards,  $\frac{g}{2}$  downwards  
 (C)  $g$  upwards,  $2g$  downwards      (D)  $2g$  upwards,  $g$  downwards
4. Two particles of mass  $m$  each are tied at the ends of a light string of length  $2a$ . The whole system is kept on a frictionless horizontal surface with the string held tight so that each mass is at the distance  $a$  from the centre  $P$  (as shown in the figure). Now, the mid-point of the string is pulled vertically upwards with a small but constant force  $F$ . As a result, the particles move towards each other on the surface. The magnitude of acceleration, when the separation between them become  $2x$ , is :-

**[IIT-JEE 2007]**

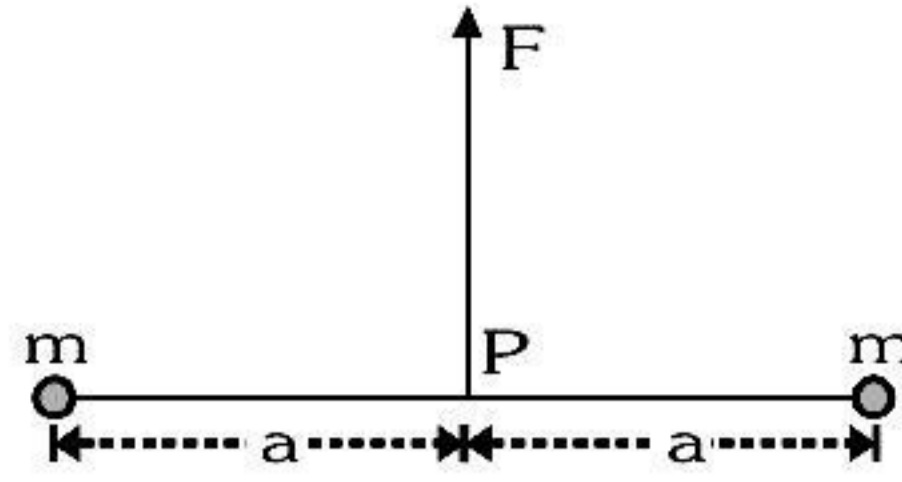

- (A)  $\frac{F}{2m} \frac{a}{\sqrt{a^2 - x^2}}$       (B)  $\frac{F}{2m} \frac{x}{\sqrt{a^2 - x^2}}$       (C)  $\frac{F}{2m} \frac{x}{a}$       (D)  $\frac{F}{2m} \frac{\sqrt{a^2 - x^2}}{x}$

5. A piece of wire is bent in the shape of a parabola  $y = kx^2$  (y-axis vertical) with a bead of mass  $m$  on it. The bead can slide on the wire without friction. It stays at the lowest point of the parabola when the wire is at rest. The wire is now accelerated parallel to the x-axis with a constant acceleration  $a$ . The distance of the new equilibrium position of the bead, where the bead can stay at rest with respect to the wire, from the y-axis is :-  
[IIT-JEE 2009]

- (A)  $\frac{a}{gk}$       (B)  $\frac{a}{2gk}$       (C)  $\frac{2a}{gk}$       (D)  $\frac{a}{4gk}$

**ASSERTION – REASON**

This question contains, statement I (assertion) and statement II (reason).

6. **Statement-I** : A cloth covers a table. Some dishes are kept on it. The cloth can be pulled out without dislodging the dishes from the table. [IIT-JEE 2007]  
**Because :**  
**Statement-II** : For every action there is an equal and opposite reaction.  
(A) statement-I is true, statement-II is true; statement-II is a correct explanation for statement-I  
(B) statement-I is true, statement-II is true, statement-II is NOT a correct explanation for statement-I  
(C) statement-I is true, statement-II is false  
(D) statement-I is false, statement-II is true