

# 31

## *Area Bounded by Curves*

Continuous curve which is bounded by under the certain condition, the space which is occupied, is called **area bounded by curves**.

### **Curve Sketching**

For the evaluation of area of bounded regions, it is very essential to know the rough sketch of the curves. The following points are very useful to draw a rough sketch of a curve.

### **Symmetry**

- (a) **Symmetry about X-axis** If all powers of  $y$  in the equation of the given curve are even, then it is symmetric about  $X$ -axis, *i. e.*, the shape of the curve above  $X$ -axis is exactly identical to its shape below  $X$ -axis.  
e.g.  $y^2 = 4ax$  is symmetric about  $X$ -axis.
- (b) **Symmetry about Y-axis** If all powers of  $x$  in the equation of the given curve are even, then it is symmetric about  $Y$ -axis.  
e.g.  $x^2 = 4ay$  is symmetric about  $Y$ -axis.
- (c) **Symmetry in opposite quadrants** If by putting  $-x$  for  $x$  and  $-y$  for  $y$ , the equation of curve remains same, then it is symmetric in opposite quadrants.  
e.g.  $xy = c^2$ ,  $x^2 + y^2 = a^2$  are symmetric in opposite quadrants.
- (d) **Symmetric about the line  $y = x$**  If the equation of a given curve remains unaltered by interchanging  $x$  and  $y$ , then it is symmetric about the line  $y = x$  which passes through the origin and makes an angle of  $45^\circ$  with positive direction of  $X$ -axis.

### IN THIS CHAPTER ...

- Curve Sketching
- Sign Convention for Finding the Areas Using Integration
- Variable Area, Greatest and Least Values

## Origin and Tangents at the Origin

See whether the curve passes through origin or not. If the point  $(0, 0)$  satisfies the equation of the curve, then it passes through the origin and in such a case to find the equations of the tangents at the origin, equate the lowest degree term to zero.

e.g.  $y^2 = 4ax$  passes through the origin. The lowest degree term in this equation is  $4ax$ . Equating  $4ax$  to zero, we get  $x = 0$ .

So,  $x = 0$ , i.e.  $Y$ -axis is tangent at the origin to  $y^2 = 4ax$ .

## Points of Intersection of the Curve with the Coordinate Axes

By putting  $y = 0$  in the equation of the given curve, find points where the curve crosses the  $X$ -axis.

Similarly, by putting  $x = 0$  in the equation of the given curve, we can find points where the curve crosses the  $Y$ -axis.

e.g. To find the points where the curve  $xy^2 = 4a^2(2a - x)$  meets  $X$ -axis, we put  $y = 0$  in the equation which gives  $4a^2(2a - x) = 0$  or  $x = 2a$ . So, the curve  $xy^2 = 4a^2(2a - x)$ , meets  $X$ -axis at  $(2a, 0)$ . This curve does not intersect  $Y$ -axis, because by putting  $x = 0$  in the equation of the given curve we get an absurd result.

## Asymptotes

- Equate coefficient of highest power of  $x$  to get asymptote parallel to  $X$ -axis.
- Similarly, equate coefficient of highest power of  $y$  to get asymptote parallel to  $Y$ -axis.

**Note** While constructing the graphs of functions, it is expedient to follow the procedure given below

- Find the domain of definition of the function.
- Determine the odd-even nature of the function.
- Find the period of the function if its periodic.
- Find the asymptotes of the function.
- Check the behaviour of the function for  $x \rightarrow 0^\pm$
- Find the value of  $x$ , if possible for which  $f(x) \rightarrow 0$ .

The interval of increase and decrease of the function in its range. Hence, determine the greatest and the least values of the function, if any.

## Regions Where the Curve does not Exist

Determine the regions in which the curve does not exist. For this, find the value of  $y$  in terms of  $x$  from the equation of the curve and find the value of  $x$  for which  $y$  is imaginary. Similarly, find the value of  $x$  in terms of  $y$  and determine the values of  $y$  for which  $x$  is imaginary. The curve does not exist for these values of  $x$  and  $y$ .

e.g. The values of  $y$  obtained from  $y^2 = 4ax$  are imaginary for negative values of  $x$ .

So, the curve does not exist on the left side of  $Y$ -axis. Similarly, the curve  $a^2y^2 = x^2(a - x)$  does not exist for  $x > a$  as the values of  $y$  are imaginary for  $x > a$ .

## Special Points

Find the points at which  $\frac{dy}{dx} = 0$ . At these points the tangent to the curve is parallel to  $X$ -axis.

Find the points at which  $\frac{dx}{dy} = 0$ . At these points the tangents to the curve is parallel to  $Y$ -axis.

## Sign of $\frac{dy}{dx}$ and Points of Maxima and Minima

Find the interval in which  $\frac{dy}{dx} > 0$ . In this interval, the function is monotonically increasing, find the interval in which  $\frac{dy}{dx} < 0$ . In this interval, the function is monotonically decreasing.

Put  $\frac{dy}{dx} = 0$  and check the sign of  $\frac{d^2y}{dx^2}$  at the points so obtained, to find the points of maxima and minima.

Keeping the above facts in mind and plotting some points on the curve one can easily have a rough sketch of the curve.

Following examples will clear the procedure.

**Example 1.** The graph of the function  $f(x) = \frac{x^2 - 1}{x^2 + 1}$  is

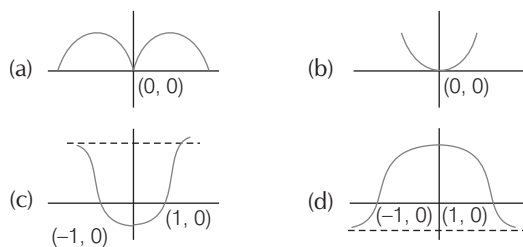

**Sol.** (c) Here,

$$f(x) = \frac{x^2 - 1}{x^2 + 1} = y \quad (\text{say})$$

**Symmetry** On putting  $x = -x$ , the graph is unaltered.

$\therefore$  Graph is symmetrical about  $Y$ -axis.

**Passes through origin** Since,  $(0, 0)$  not satisfies the given curve.

$\therefore$  Graph is not passing through origin.

**Intersection with coordinate axes** Put  $x = 0$ , then  $y = -1$  and put

$$y = 0, \text{ then } x = \pm 1$$

$\therefore$  Graph cuts the  $Y$ -axis at  $(0, -1)$  and the  $X$ -axis at  $(1, 0)$  and  $(-1, 0)$ .

**Asymptotes**

$$y = \frac{x^2 - 1}{x^2 + 1}$$

Here, no asymptotes is parallel to Y-axis.

(since,  $x^2 + 1 \neq 0$  for any value of  $x$ .)

Now,

$$x^2 = \frac{y + 1}{1 - y}$$

$$1 - y = 0 \text{ at } y = 1.$$

So,  $y = 1$  is an asymptote parallel to X-axis.

Hence, required graph is

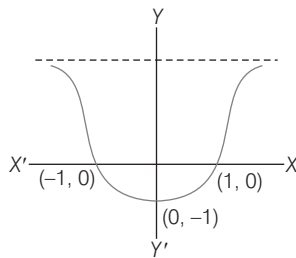

**Note**

- If function is periodic and we can find its period, then plot curve for the interval equal to one period and repeat it.
- If  $f(a)f(b) < 0$ , curve intersects X-axis atleast once. Similarly, iff  $f(a)f(b) > 0$  curve intersects X-axis even number of times.

**Example 2.** The graph of the function

$$f(x) = x + \frac{1}{x} \text{ is}$$

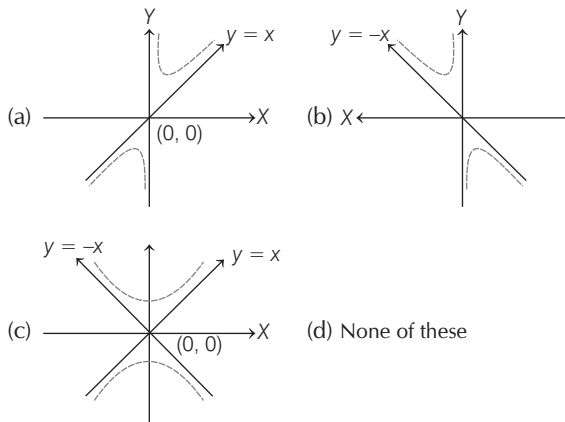

**Sol.** (a) The function is defined for all  $x$  except for  $x = 0$ .

It is an odd function for  $x \neq 0$ .

It is not a periodic function.

For  $x \rightarrow 0^+$ ,  $f(x) \rightarrow +\infty$ , for  $x \rightarrow 0^-$ ,  $f(x) \rightarrow -\infty$

For  $x \rightarrow -\infty$ ,  $f(x) \rightarrow -\infty$ , for  $x \rightarrow \infty$ ,  $f(x) \rightarrow \infty$

$$\therefore \lim_{x \rightarrow \pm \infty} \{f(x) - x\} = 0$$

$\therefore$  The straight lines  $x = 0$  and  $y = x$  are the asymptotes of the graph of the given function.

Now, consider  $f(x_2) - f(x_1)$  (for  $x_2 > x_1$ )

$$= (x_2 - x_1) + \frac{1}{x_2} - \frac{1}{x_1}$$

$$= (x_2 - x_1) \left[ 1 - \frac{1}{x_1 x_2} \right] < 0 \text{ for } x_1 x_2 \in (0, 1]$$

and it is  $> 0$  for  $x_1 x_2 \in [1, \infty)$ .

Thus,  $f(x)$  increases for  $x \in [1, \infty)$  and decreases for  $x \in (0, 1]$ .

Thus, the least value of the function is at  $x = 1$  which is  $f(1) = 2$ .

Thus, its graph can be drawn as

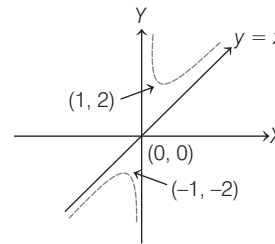

**Example 3.** The graph of the function  $f(x) = \frac{1}{1 + e^{1/x}}$  is

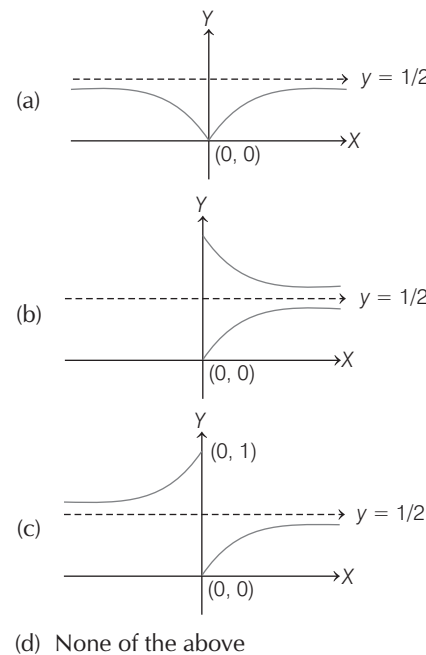

**Sol.** (c) The function is defined for all  $x$  except for  $x = 0$ . It is neither even nor an odd function. It is not a periodic function.

For  $x \rightarrow 0^+$ ,  $f(x) \rightarrow 0$  for  $x \rightarrow 0^-$ ,  $f(x) \rightarrow 1$

For  $x \rightarrow \infty$ ,  $f(x) \rightarrow \frac{1}{2}$  for  $x \rightarrow -\infty$ ,  $f(x) \rightarrow \frac{1}{2}$

$$\therefore \lim_{x \rightarrow \pm \infty} f(x) = \frac{1}{2}$$

$\therefore$  The straight line  $y = \frac{1}{2}$  is asymptote of the graph of the given function.



(iii) The area bounded by the curve  $x = F(y)$  right to the Y-axis and the lines  $y = c, y = d$  is given by

$$\int_c^d x \, dy = \int_c^d F(y) \, dy$$

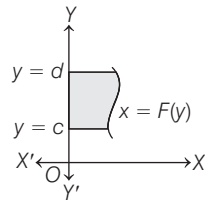

(iv) If the curve between the lines  $y = c, y = d$  left to the Y-axis, then the area is given by

$$\left| \int_c^d (-x) \, dy \right| = \left| - \int_c^d x \, dy \right| = \left| - \int_c^d F(y) \, dy \right|$$

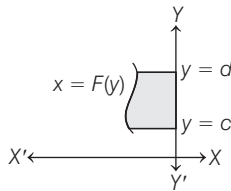

When ever we solve this type of question. Generally, we follow the steps given below.

- (i) First we sketch the given curve.
- (ii) Now, we find the intersection of curve with axis and given line.
- (iii) We select the bounded region in the figure and take interval between bounded region.
- (iv) Now, we apply the appropriate formula to calculate the area of bounded region.

**Example 5.** The area of the region bounded by the curve  $y^2 = x$  and the lines  $x = 1, x = 4$  and the X-axis in the first quadrant is

- |                             |                            |
|-----------------------------|----------------------------|
| (a) $\frac{14}{3}$ sq units | (b) $\frac{7}{3}$ sq units |
| (c) $\frac{11}{3}$ sq units | (d) None of these          |

**Sol.** (a) The area enclosed by the curve  $y = f(x)$ , the X-axis and the abscissa  $x = a, x = b$  is given by  $A = \int_a^b |y| \, dx$ .

The area of the region bounded by the curve,  $y^2 = x$ , the lines  $x = 1$  and  $x = 4$  and the X-axis is shown in the figure.

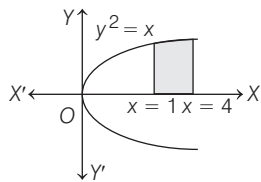

Here,  $a = 1, b = 4$

Since, the given curve  $y^2 = x$  is parabola which is symmetrical about X-axis ( $\because$  it contains even power of Y) and passes through the origin.

$\therefore$  Required area (shaded region)

$$\begin{aligned} &= \int_a^b |y| \, dx = \int_1^4 |y| \, dx = \int_1^4 \sqrt{x} \, dx \quad (\because y^2 = x, \therefore |y| = \sqrt{x}) \\ &= \left[ \frac{x^{3/2}}{\frac{3}{2}} \right]_1^4 = \frac{2}{3} [4^{3/2} - 1^{3/2}] = \frac{2}{3} [(2^2)^{3/2} - 1] \\ &= \frac{2}{3} [8 - 1] = \frac{14}{3} \text{ sq units} \end{aligned}$$

**Example 6.** The area of the region bounded by  $x^2 = 4y, y = 2, y = 4$  and the Y-axis in the first quadrant is

- |  |                               |
|--|-------------------------------|
| (a) $(4 - \sqrt{2})$ sq units            | (b) $(4 + \sqrt{2})$ sq units |
| (c) $\frac{8}{3}(4 - \sqrt{2})$ sq units | (d) None of these             |

**Sol.** (c) To determine the required area, integrate  $x$  w.r.t.  $y$  and take  $y = 2$  as lower limit and  $y = 4$  as upper limit. The given curve  $x^2 = 4y$  is a parabola, which is symmetrical about Y-axis.

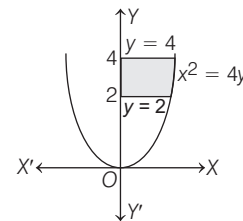

[ $\because$  it contains even power of  $x$ ) only and passes through the origin]

The area of the region bounded by the curve  $x^2 = 4y, y = 2$  and  $y = 4$  and the Y-axis is shown in the figure.

Required area (shaded region) =  $\int_{y=a}^{y=b} |x| \, dy$

$$\begin{aligned} &[\text{here, } |x| = \sqrt{4y} \text{ and } a = 2, b = 4] = \int_2^4 |x| \, dy \\ &\text{considering the elementary strip on Y-axis]} \\ &= \int_2^4 2\sqrt{y} \, dy \quad [\because x^2 = 4y, \therefore |x| = 2\sqrt{y}] \\ &= 2 \left[ \frac{y^{3/2}}{\frac{3}{2}} \right]_2^4 = \frac{4}{3} [4^{3/2} - 2^{3/2}] \\ &= \frac{4}{3} [8 - 2\sqrt{2}] \\ &= \frac{8}{3} [4 - \sqrt{2}] \text{ sq units} \end{aligned}$$

**Example 7.** Let  $S(\alpha) = \{(x, y) : y^2 \leq x, 0 \leq x \leq \alpha\}$  and  $A(\alpha)$  is area of the region  $S(\alpha)$ . If for  $\lambda, 0 < \lambda < 4, A(\lambda) : A(4) = 2 : 5$ , then  $\lambda$  equals

(JEE Main 2019)

- |  |   |
|--|---|
| (a) $2\left(\frac{4}{25}\right)^{\frac{1}{3}}$ | (b) $4\left(\frac{2}{5}\right)^{\frac{1}{3}}$ |
| (c) $4\left(\frac{4}{25}\right)^{\frac{1}{3}}$ | (d) $2\left(\frac{2}{5}\right)^{\frac{1}{3}}$ |

**Sol.** (c) Given,  $S(\alpha) = \{(x, y) : y^2 \leq x, 0 \leq x \leq \alpha\}$  and  $A(\alpha)$  is area of the region  $S(\alpha)$

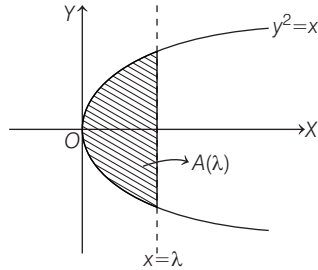

$$\text{Clearly, } A(\lambda) = 2 \int_0^\lambda \sqrt{x} \, dx = 2 \left[ \frac{x^{3/2}}{3/2} \right]_0^\lambda = \frac{4}{3} \lambda^{3/2}$$

$$\text{Since, } \frac{A(\lambda)}{A(4)} = \frac{2}{5}, \quad (0 < \lambda < 4)$$

$$\Rightarrow \frac{\lambda^{3/2}}{4^{3/2}} = \frac{2}{5} \Rightarrow \left(\frac{\lambda}{4}\right)^3 = \left(\frac{2}{5}\right)^2$$

$$\Rightarrow \frac{\lambda}{4} = \left(\frac{4}{25}\right)^{1/3} \Rightarrow \lambda = 4 \left(\frac{4}{25}\right)^{1/3}$$

## Area between the Given Curves

Area bounded by the curves  $y = f(x)$ ,  $y = g(x)$  and the lines  $x = a$  and  $x = b$ .

Let the curves  $y = f(x)$  and  $y = g(x)$  be represented by  $AB$  and  $CD$ , respectively. We assume that the two curves do not intersect each other in the interval  $[a, b]$ .

Thus, the shaded area

$$\begin{aligned} &= \text{Area of curvilinear trapezoid } APQB \\ &\quad - \text{Area of curvilinear trapezoid } CPQD \\ &= \int_a^b f(x) \, dx - \int_a^b g(x) \, dx = \int_a^b \{f(x) - g(x)\} \, dx \end{aligned}$$

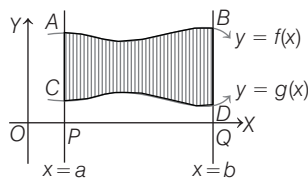

Now, consider the case when  $f(x)$  and  $g(x)$  intersect each other in the interval  $[a, b]$ .

First of all we should find the intersection point of  $y = f(x)$  and  $y = g(x)$ . For that we solve  $f(x) = g(x)$ .

Let the root is  $x = c$ .

(we consider only one intersection point to illustrate the phenomenon).

Thus, the required (shaded) area

$$= \int_a^c \{g(x) - f(x)\} \, dx + \int_c^b \{f(x) - g(x)\} \, dx$$

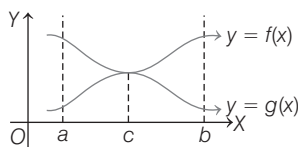

If confusion arises in such case evaluate  $\int_a^b |f(x) - g(x)| \, dx$  which gives the required area.

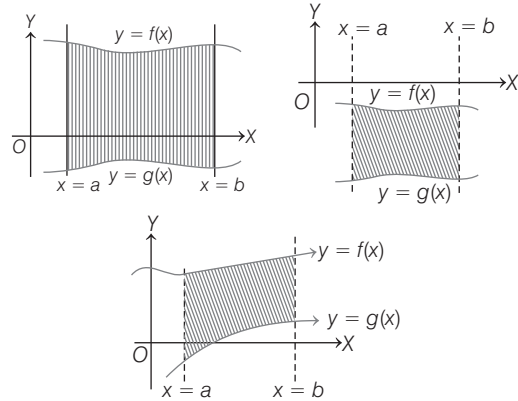

Area between two curves  $y = f(x)$ ,  $y = g(x)$  and the lines  $x = a$  and  $x = b$  is always given by  $\int_a^b \{f(x) - g(x)\} \, dx$  provided  $f(x) > g(x)$  in  $[a, b]$ ; the position of the graph is immaterial, as shown in figures.

Whenever, we solve such types of problems, generally we follow the steps given below.

- (i) First, we sketch the given curves. (if necessary)
- (ii) Now, we find the intersection points of the given curves by solving them.
- (iii) Now, we select the bounded region in the figure of curves and take the interval between bounded region.
- (iv) Now, we apply the appropriate formula to calculate the area of bounded region.

**Example 8.** The area of the region in the first quadrant enclosed by X-axis and  $x = \sqrt{3}y$  and the circle  $x^2 + y^2 = 4$  is

- (a) 0 sq unit    (b)  $\frac{3\pi}{4}$  sq units    (c)  $\frac{\pi}{3}$  sq units    (d)  $\frac{\pi}{2}$  sq units

**Sol.** (c) Firstly, find the intersection point of  $x = \sqrt{3}$  and  $x^2 + y^2 = 4$  in the first quadrant and then draw a rough diagram to indicate the required area. Now, divide the area into two parts one lying under the line joining point of intersection to  $(0, 0)$  and other lying under the circle and then integrate separately to find required area.

Given equation of circle is  $x^2 + y^2 = 4$

and  $x = \sqrt{3}y$  or  $y = \frac{1}{\sqrt{3}}x$

represents a line through the origin.

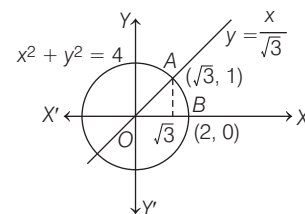

The line  $y = \frac{1}{\sqrt{3}}x$  intersect the circle, so it will satisfy the equation of circle

$$\therefore x^2 + \left(\frac{1}{\sqrt{3}}x\right)^2 = 4 \Rightarrow \frac{4}{3}x^2 = 4$$

$$\Rightarrow x^2 = \frac{4 \times 3}{4} = 3 \Rightarrow x = \pm \sqrt{3}$$

$$\text{When } x = \sqrt{3}, \text{ then } y = \frac{1}{\sqrt{3}} \sqrt{3} = 1$$

[for first quadrant we take  $x = \sqrt{3}$  and neglect  $x = -\sqrt{3}$ ]

$\therefore$  The line and the circle meet at the point  $(\sqrt{3}, 1)$ .

Required area (shaded region in first quadrant)

$$= (\text{Area under the line } y = \frac{1}{\sqrt{3}}x \text{ from } x=0 \text{ to } x=\sqrt{3})$$

$$+ (\text{Area under the circle from } x=\sqrt{3} \text{ to } x=2)$$

$$= \int_0^{\sqrt{3}} \frac{1}{\sqrt{3}}x \, dx + \int_{\sqrt{3}}^2 \sqrt{4-x^2} \, dx \quad (\because x^2 + y^2 = 4 \Rightarrow y = \sqrt{4-x^2})$$

$$= \frac{1}{\sqrt{3}} \left[ \frac{x^2}{2} \right]_0^{\sqrt{3}} + \left[ \frac{x}{2} \sqrt{4-x^2} + \frac{2^2}{2} \sin^{-1} \left( \frac{x}{2} \right) \right]_{\sqrt{3}}^2$$

$$= \frac{1}{2\sqrt{3}} [(\sqrt{3})^2 - 0^2] + \left[ 0 + 2 \sin^{-1}(1) - \frac{\sqrt{3}}{2} \sqrt{4-3} - 2 \sin^{-1} \left( \frac{\sqrt{3}}{2} \right) \right]$$

$$= \frac{\sqrt{3}}{2} + 2 \left( \frac{\pi}{2} \right) - \frac{\sqrt{3}}{2} - 2 \left( \frac{\pi}{3} \right) = \pi - \frac{2\pi}{3} = \frac{\pi}{3} \text{ sq units}$$

**Example 9.** The area of the circle  $4x^2 + 4y^2 = 9$  which is interior to the parabola  $x^2 = 4y$  is

$$(a) \frac{1}{6} + \frac{1}{4} \sin^{-1} \left( \frac{2\sqrt{2}}{3} \right) \text{ sq unit}$$

$$(b) \frac{\sqrt{2}}{6} + \frac{9}{4} \sin^{-1} \left( \frac{2\sqrt{2}}{3} \right) \text{ sq unit}$$

$$(c) \frac{1}{\sqrt{2}} + \frac{1}{\sqrt{3}} \sin^{-1} \left( 2 \cdot \frac{\sqrt{2}}{3} \right) \text{ sq unit}$$

(d) None of the above

**Sol.** (b) Given, circle is  $4x^2 + 4y^2 = 9$  and the given parabola is

$x^2 = 4y$ . The two curves meet where

$$4(4y) + 4y^2 = 9 \Rightarrow 4y^2 + 16y - 9 = 0$$

$$\Rightarrow y = \frac{-16 \pm \sqrt{256 + 144}}{2 \times 4} = \frac{-16 \pm \sqrt{400}}{8} = \frac{-16 \pm 20}{8} = \frac{1}{2}, -\frac{9}{2}$$

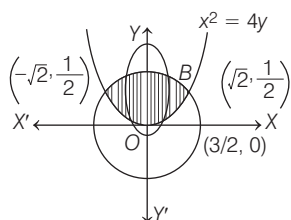

But  $y > 0$ , therefore the two curves meet when  $y = \frac{1}{2}$ .

When  $x^2 = 4 \times \frac{1}{2} = 2$ , i.e., when  $x = \pm \sqrt{2}$

$\therefore$  Required area (shown in shaded region)

$$= 2 \int_0^{\sqrt{2}} (y_2 - y_1) \, dx = 2 \left\{ \int_0^{\sqrt{2}} \sqrt{\frac{9-4x^2}{4}} \, dx - \int_0^{\sqrt{2}} \frac{x^2}{4} \, dx \right\}$$

$$= 2 \int_0^{\sqrt{2}} \left[ \left( \frac{3}{2} \right)^2 - x^2 \right]^{1/2} dx - \frac{2}{4} \left[ \frac{x^3}{3} \right]_0^{\sqrt{2}}$$

$$= 2 \left[ \frac{x}{2} \sqrt{\left( \frac{3}{2} \right)^2 - x^2} + \frac{\left( \frac{3}{2} \right)^2}{2} \sin^{-1} \left( \frac{x}{\frac{3}{2}} \right) \right]_0^{\sqrt{2}} - \frac{1}{6} [(\sqrt{2})^3 - 0]$$

$$= \left[ x \sqrt{\frac{9}{4} - x^2} + \frac{9}{4} \sin^{-1} \left( \frac{2x}{3} \right) \right]_0^{\sqrt{2}} - \frac{2\sqrt{2}}{6}$$

$$= \left[ \sqrt{2} \sqrt{\frac{9}{4} - 2} + \frac{9}{4} \sin^{-1} \left( \frac{2\sqrt{2}}{3} \right) \right] - \{0 - 0\} - \frac{2\sqrt{2}}{6}$$

$$= \frac{\sqrt{2}}{2} + \frac{9}{4} \sin^{-1} \left( \frac{2\sqrt{2}}{3} \right) - \frac{2\sqrt{2}}{6}$$

$$= \left( \frac{\sqrt{2}}{2} - \frac{\sqrt{2}}{3} \right) + \frac{9}{4} \sin^{-1} \left( \frac{2\sqrt{2}}{3} \right)$$

$$= \frac{\sqrt{2}}{6} + \frac{9}{4} \sin^{-1} \left( \frac{2\sqrt{2}}{3} \right) \text{ sq unit}$$

**Example 10.** The area bounded by the curves

$(x-1)^2 + y^2 = 1$  and  $x^2 + y^2 = 1$  is

$$(a) \left( \frac{\pi}{3} - \frac{1}{\sqrt{3}} \right) \text{ sq unit}$$

$$(b) \frac{1}{2} \left( \frac{\pi}{\sqrt{3}} - \frac{1}{2} \right) \text{ sq unit}$$

$$(c) \left( \frac{2\pi}{3} - \frac{\sqrt{3}}{2} \right) \text{ sq unit}$$

(d) None of these

**Sol.** (c) Given, curve  $(x-1)^2 + y^2 = 1$

... (i)

$$\therefore y = \sqrt{1 - (x-1)^2}$$

which represents a circle with centre  $(1, 0)$  and radius 1 and curve

$$x^2 + y^2 = 1$$

... (ii)

$$\therefore y = \sqrt{1 - x^2}$$

which represents a circle with centre  $(0, 0)$  and radius 1.

Both the curves are circle and meet where  $(x-1)^2 = x^2$

i.e. where  $2x = 1$  or  $x = \frac{1}{2}$ .

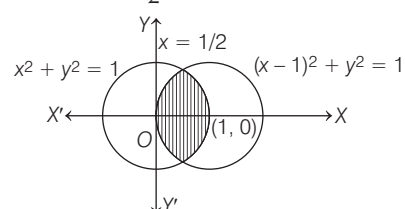

Required area (shown in shaded region)

$$\begin{aligned}
 &= 2 \left[ \int_0^{1/2} y_1 dx + \int_{1/2}^1 y_2 dx \right] \\
 &= 2 \left\{ \int_0^{1/2} \sqrt{1-(x-1)^2} dx + \int_{1/2}^1 \sqrt{1-x^2} dx \right\} \\
 &= 2 \left[ \frac{x-1}{2} \sqrt{1-(x-1)^2} + \frac{1}{2} \sin^{-1} \frac{x-1}{1} \right]_0^{1/2} \\
 &\quad + 2 \left[ \frac{x}{2} \sqrt{1-x^2} + \frac{1}{2} \sin^{-1} x \right]_{1/2}^1 \\
 &= 2 \left[ \frac{1}{2} \sin^{-1} \sqrt{1-\frac{1}{4}} + \frac{1}{2} \sin^{-1} \left( -\frac{1}{2} \right) - \left( -\frac{1}{2} \right) \cdot 0 - \frac{1}{2} \sin^{-1} (-1) \right] \\
 &\quad + 2 \left[ 0 + \frac{1}{2} \sin^{-1}(1) - \frac{1}{4} \sqrt{1-\frac{1}{4}} - \frac{1}{2} \sin^{-1} \frac{1}{2} \right] \\
 &= 2 \left[ -\frac{1}{4} \cdot \frac{\sqrt{3}}{2} - \frac{1}{2} \cdot \frac{\pi}{6} + 0 + \frac{1}{2} \cdot \frac{\pi}{2} \right] + \frac{\pi}{2} - \frac{1}{2} \cdot \frac{\sqrt{3}}{2} - \frac{\pi}{6} \\
 &= -\frac{\sqrt{3}}{4} - \frac{\pi}{6} + \frac{\pi}{2} + \frac{\pi}{2} - \frac{\sqrt{3}}{4} - \frac{\pi}{6} \\
 &= \left( \frac{2\pi}{3} - \frac{\sqrt{3}}{2} \right) \text{ sq unit}
 \end{aligned}$$

**Example 11.** Area (in sq units) of the region outside

$\frac{|x|}{2} + \frac{|y|}{3} = 1$  and inside the ellipse  $\frac{x^2}{4} + \frac{y^2}{9} = 1$  is (JEE Main 2020)

- (a)  $6(\pi - 2)$     (b)  $3(\pi - 2)$     (c)  $3(4 - \pi)$     (d)  $6(4 - \pi)$

**Sol.** (a) Equation of given curves

$$\frac{|x|}{2} + \frac{|y|}{3} = 1 \quad \dots (i)$$

and

$$\frac{x^2}{4} + \frac{y^2}{9} = 1 \quad \dots (ii)$$

On plotting the graph of given curves due to symmetry, we can say the required area (area of shaded region)

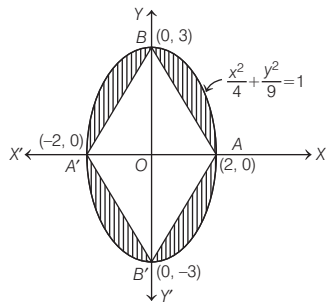

= Area enclosed by ellipse - 4 (Area of  $\Delta AOB$ )

$$= \pi(2)(3) - 4 \left( \frac{1}{2} \times 2 \times 3 \right)$$

[ $\because$  area enclosed by ellipse  $\frac{x^2}{a^2} + \frac{y^2}{b^2} = 1$  is  $\pi ab$  sq units]

$$= 6\pi - 12 = 6(\pi - 2) \text{ sq units}$$

**Example 12.** Consider region  $R = \{(x, y) \in R^2 : x^2 \leq y \leq 2x\}$ . If a line  $y = \alpha$  divides the area of region  $R$  into two equal parts, then which of the following is true? (JEE Main 2020)

- (a)  $\alpha^3 - 6\alpha^2 + 16 = 0$     (b)  $3\alpha^2 - 8\alpha^{3/2} + 8 = 0$   
 (c)  $3\alpha^2 - 8\alpha + 8 = 0$     (d)  $\alpha^3 - 6\alpha^{3/2} - 16 = 0$

**Sol.** (b) According to the question,

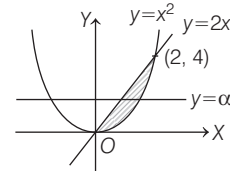

$$\int_0^\alpha \left( \sqrt{y} - \frac{y}{2} \right) dy = \int_{\alpha/2}^4 \left( \sqrt{y} - y/2 \right) dy$$

$$\Rightarrow \frac{\alpha\sqrt{\alpha}}{3/2} - \frac{\alpha^2}{4} = \frac{4(2)}{3/2} - \frac{16}{4} - \frac{\alpha\sqrt{\alpha}}{3/2} + \frac{\alpha^2}{4}$$

$$\Rightarrow \frac{4}{3} \alpha\sqrt{\alpha} = \frac{\alpha^2}{2} + \frac{64 - 48}{12} = \frac{16}{12} = \frac{4}{3}$$

$$\Rightarrow 3\alpha^2 - 8\alpha^{3/2} + 8 = 0$$

Hence, option (b) is correct.

**Example 13.** The area (in sq units) of the region

$\{(x, y) : 0 \leq y \leq x^2 + 1, 0 \leq y \leq x + 1, \frac{1}{2} \leq x \leq 2\}$  is (JEE Main 2020)

- (a)  $\frac{23}{16}$     (b)  $\frac{79}{24}$     (c)  $\frac{79}{16}$     (d)  $\frac{23}{6}$

**Sol.** (b) Given region

$$\{(x, y) : 0 \leq y \leq x^2 + 1, 0 \leq y \leq x + 1, \frac{1}{2} \leq x \leq 2\}$$

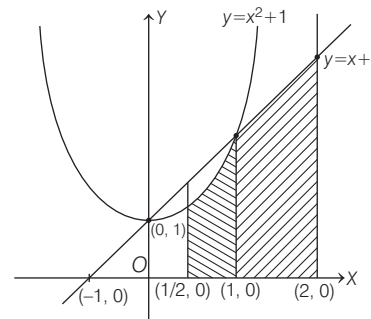

= Shaded region in the figure

$\therefore$  Area of required region is

$$= \int_{1/2}^1 (x^2 + 1) dx + \int_1^2 (x + 1) dx$$

$$= \left[ \frac{x^3}{3} + x \right]_{1/2}^1 + \left[ \frac{x^2}{2} + x \right]_1^2$$

$$= \frac{1}{3} + 1 - \frac{1}{24} - \frac{1}{2} + \frac{4}{2} + 2 - \frac{1}{2} - 1$$

$$= 3 + \frac{1}{3} - \frac{1}{24} = \frac{72 + 8 - 1}{24} = \frac{79}{24} \text{ sq unit}$$

**Example 14.** The area (in sq units) of the largest rectangle ABCD whose vertices A and B lie on the X-axis and vertices C and D lie on the parabola,  $y = x^2 - 1$  below the X-axis, is

(JEE Main 2020)

- (a)  $\frac{4}{3\sqrt{3}}$  (b)  $\frac{2}{3\sqrt{3}}$  (c)  $\frac{1}{3\sqrt{3}}$  (d)  $\frac{4}{3}$

**Sol.** (a) Equation of given parabola  $y = x^2 - 1$

According to symmetry let, the coordinate of  $A(-a, 0), B(a, 0)$

$C(a, a^2 - 1)$  and  $D(-a, a^2 - 1)$ .

$\therefore$  Area of rectangle  $P(a) = 2a(a^2 - 1)$

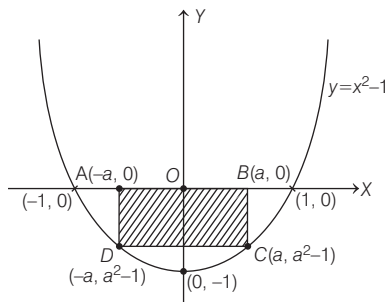

Now, for maxima  $P'(a) = 0 \Rightarrow 2(a^2 - 1) + 4a^2 = 0$

$$\Rightarrow 3a^2 = 1 \Rightarrow a = \frac{1}{\sqrt{3}} \text{ units}$$

$\therefore$  Area of largest rectangle is  $\left| \frac{2}{\sqrt{3}} \left( \frac{1}{3} - 1 \right) \right| = \frac{4}{3\sqrt{3}}$  sq units

**Example 15.** The area (in sq. units) of the region  $A = \{(x, y) : (x-1)[x] \leq y \leq 2\sqrt{x}, 0 \leq x \leq 2\}$ , where  $[x]$  denotes the greatest integer function, is

(JEE Main 2020)

- (a)  $\frac{8}{3}\sqrt{2} - \frac{1}{2}$  (b)  $\frac{4}{3}\sqrt{2} + 1$  (c)  $\frac{8}{3}\sqrt{2} - 1$  (d)  $\frac{4}{3}\sqrt{2} - \frac{1}{2}$

**Sol.** (a) As we know that,  $y = (x-1)[x] = \begin{cases} 0, & 0 \leq x < 1 \\ x-1, & 1 \leq x < 2 \\ 2(x-1), & x = 2 \end{cases}$

Now, on drawing the graph of given region with the help of equation of curves

$$y = (x-1)[x] \text{ and } y = 2\sqrt{x}$$

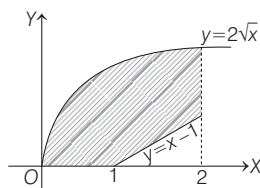

$$\begin{aligned} \therefore \text{Area of given region} &= \int_0^1 2\sqrt{x} \, dx + \int_1^2 (2\sqrt{x} - x + 1) \, dx \\ &= \left[ \frac{4}{3} x^{3/2} \right]_0^1 + \left[ \frac{4}{3} x^{3/2} - \frac{x^2}{2} + x \right]_1^2 \\ &= \frac{4}{3} + \left[ \frac{8\sqrt{2}}{3} - 2 + 2 - \frac{4}{3} + \frac{1}{2} - 1 \right] \\ &= \frac{8\sqrt{2}}{3} - \frac{1}{2} \text{ sq units.} \end{aligned}$$

**Example 16.** The area (in sq units) of the region

$A = \{(x, y) : |x| + |y| \leq 1, 2y^2 \geq |x|\}$  is

(JEE Main 2020)

- (a)  $\frac{1}{3}$  (b)  $\frac{7}{6}$  (c)  $\frac{1}{6}$  (d)  $\frac{5}{6}$

**Sol.** (d) The area of the given region

$$A = \{(x, y) : |x| + |y| \leq 1, 2y^2 \geq |x|\}$$

by the figure due to symmetry

$$A = 4 \int_0^{1/2} \left( 1 - x - \sqrt{\frac{x}{2}} \right) dx$$

$$[\because 2y^2 + y - 1 = 0 \Rightarrow (2y - 1)(y + 1) = 0 \Rightarrow y = \frac{1}{2}]$$

$$= 4 \left[ x - \frac{x^2}{2} - \frac{2x^{3/2}}{3\sqrt{2}} \right]_0^{1/2}$$

$$= 4 \left[ \frac{1}{2} - \frac{1}{8} - \frac{2}{12} \right]$$

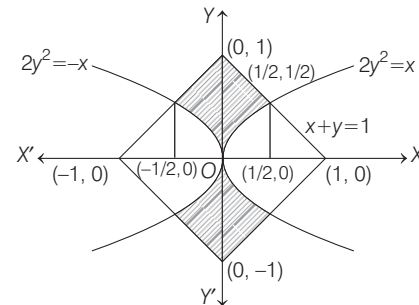

$$= 4 \left[ \frac{12 - 3 - 4}{24} \right]$$

$$= \frac{5}{6} \text{ sq units}$$

**Example 17.** The area (in sq. units) of the region enclosed by the curves  $y = x^2 - 1$  and  $y = 1 - x^2$  is equal to

(JEE Main 2020)

- (a)  $\frac{4}{3}$  (b)  $\frac{8}{3}$  (c)  $\frac{7}{2}$  (d)  $\frac{16}{3}$

**Sol.** (b) From the graph of given curves, due to symmetry the area of the region enclosed

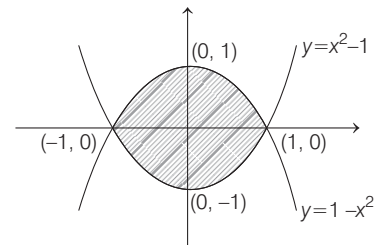

$$= 4 \int_0^1 (1 - x^2) \, dx = 4 \left[ x - \frac{x^3}{3} \right]_0^1$$

$$= 4 \left( \frac{2}{3} \right) = \frac{8}{3} \text{ sq units}$$

**Example 18.** The area of the region, enclosed by the circle  $x^2 + y^2 = 2$  which is not common to the region bounded by the parabola  $y^2 = x$  and the straight line  $y = x$ , is

(JEE Main 2020)

- (a)  $\frac{1}{3}(12\pi - 1)$  (b)  $\frac{1}{6}(12\pi - 1)$  (c)  $\frac{1}{6}(24\pi - 1)$  (d)  $\frac{1}{3}(6\pi - 1)$

**Sol.** (b) Let the area of the region, enclosed by the parabola  $y^2 = x$  and straight line  $y = x$  is

$$A = \int_0^1 (\sqrt{x} - x) dx$$

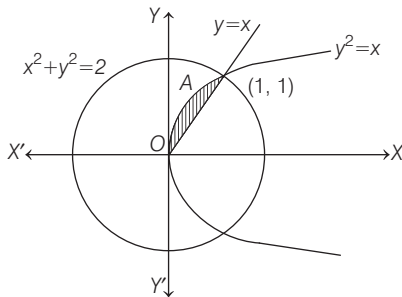

$$= \left[ \frac{x^{3/2}}{3/2} - \frac{x^2}{2} \right]_0^1 = \left( \frac{1}{3/2} - \frac{1}{2} \right) = \left( \frac{2}{3} - \frac{1}{2} \right) = \frac{4-3}{6} = \frac{1}{6}$$

$\therefore$  Area of circle having radius  $r = \sqrt{2}$  unit is  $\pi r^2 = 2\pi$   
 $\therefore$  The area of the region, enclosed by the circle  $x^2 + y^2 = 2$ , which is not common to the region bounded by the parabola  $y^2 = x$  and the straight line  $y = x$ , is  $2\pi - \frac{1}{6} = \frac{1}{6}(12\pi - 1)$ .

**Example 19.** The area (in sq units) of the region

$\{(x, y) \in R^2 \mid 4x^2 \leq y \leq 8x + 12\}$  is

(JEE Main 2020)

- (a)  $\frac{124}{3}$  (b)  $\frac{125}{3}$  (c)  $\frac{127}{3}$  (d)  $\frac{128}{3}$

**Sol.** (d) The area of region  $\{(x, y) \in R^2 \mid 4x^2 \leq y \leq 8x + 12\}$  is area of region bounded by curves  $y = 4x^2$  and  $y = 8x + 12$ .

To get the point of intersection of curves, on eliminating  $y$ , we get

$$4x^2 = 8x + 12$$

$$\Rightarrow x^2 - 2x - 3 = 0 \Rightarrow x = -1, 3$$

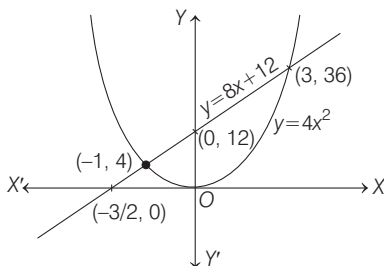

$$\text{So, required area} = \int_{-1}^3 (8x + 12 - 4x^2) dx$$

$$= \left[ \frac{8x^2}{2} + 12x - 4 \frac{x^3}{3} \right]_{-1}^3 = \{(4 \times 9) + (12 \times 3) - (4 \times 9)\} - \left\{ 4 - 12 + \frac{4}{3} \right\} = 36 + \frac{20}{3} = \frac{128}{3} \text{ sq units}$$

## Variable Area, Greatest and Least Values

If  $y = f(x)$  is a monotonic function in  $(a, b)$ , then the area bounded by the abscissa at  $x = a, x = b, y = f(x)$  and  $y = f(c)$ , [where  $c \in (a, b)$ ] is minimum, when  $c = \frac{a+b}{2}$ .

**Example 20.** If the area bounded by  $f(x) = \frac{x^3}{3} - x^2 + a$  and the straight lines  $x = 0; x = 2$  and the X-axis is minimum, then the value of  $a$  is

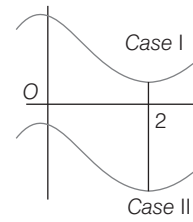

- (a)  $\frac{1}{3}$  (b)  $\frac{2}{3}$  (c)  $\frac{5}{3}$  (d) None of these

**Sol.** (b)  $f'(x) = x^2 - 2x = x(x - 2) = 0$

[note that  $f(x)$  is monotonic in  $(0, 2)$ ]

Thus, for the minimum  $f(x)$  must cross the X-axis at  $\frac{0+2}{2} = 1$ .

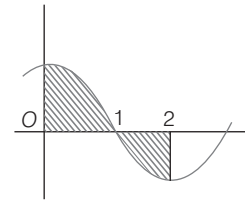

$$\text{Hence, } f(1) = \frac{1}{3} - 1 + a = 0 \Rightarrow a = \frac{2}{3}$$

**Example 21.** The value of the parameter  $a$  for which the area of the figure bounded by the abscissa axis, the graph of the function  $y = x^3 + 3x^2 + x + a$  and the straight lines, which are parallel to the axis of ordinates and cut the abscissa axis at the point of extremum of the function, is the least is

- (a) 1 (b) -1 (c) 0 (d) None of these

**Sol.** (b)  $f(x) = x^3 + 3x^2 + x + a; f'(x) = 3x^2 + 6x + 1 = 0$

$$\Rightarrow x = -1 \pm \frac{\sqrt{6}}{3}$$

$$\text{Hence, } f(x) \text{ cuts the X-axis at } \frac{1}{2} \left[ \left( -1 + \frac{\sqrt{6}}{3} \right) + \left( -1 - \frac{\sqrt{6}}{3} \right) \right] = -1$$

$$f(-1) = -1 + 3 - 1 + a = 0 \Rightarrow a = -1$$

### Area of Important Curves

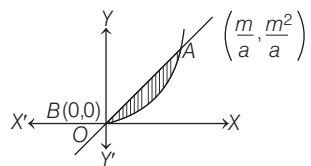
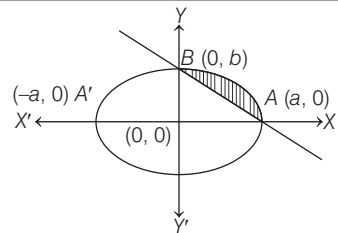
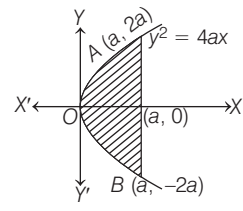
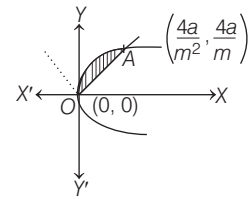
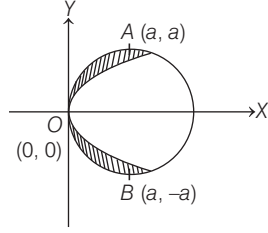
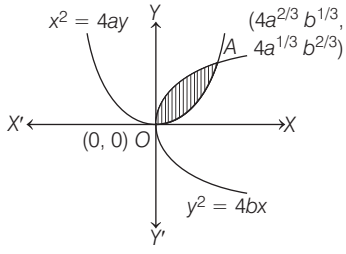
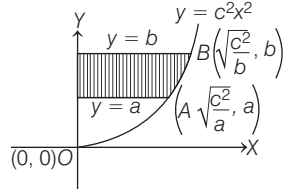
Curves	Point of intersection	Area of shaded region
(i) $f(x, y) : ax^2 \leq y \leq mx$ $\therefore y = ax^2, y = mx$	$B(0, 0), A\left(\frac{m}{a}, \frac{m^2}{a}\right)$	Area = $\frac{1}{6} \frac{m^3}{a^2}$ sq unit
		
(ii) $f(x, y) : \frac{x^2}{a^2} + \frac{y^2}{b^2} \leq 1,$ $\frac{x}{a} + \frac{y}{b} \geq 1$ $\Rightarrow \frac{x^2}{a^2} + \frac{y^2}{b^2} \leq 1 \leq \frac{x}{a} + \frac{y}{b}$	$A(a, 0), B(0, b)$	Area = $ab \frac{(\pi - 2)}{4}$ sq unit
		
(iii) Area of parabola $y^2 = 4ax$ and its latusrectum $x = a$	$A(a, 2a), B(a, -2a)$	Area = $\frac{8}{3} a^2$ sq units
		
(iv) $f(x, y) : y^2 = 4ax$ and $y =  mx $	$O(0, 0), A\left(\frac{4a}{m^2}, \frac{4a}{m}\right)$	Area = $\frac{8a^2}{3m^3}$ sq unit
		
(v) $f(x, y) : x^2 + y^2 \leq 2ax$ and $y^2 \geq ax$	$O(0, 0), A(a, a), B(a, -a)$	(i) For $x \geq 0, y \geq 0$ (area of 1st quadrant) Area = $a^2 \left(\frac{\pi}{4} - \frac{2}{3}\right)$ sq unit  (ii) For $x \geq 0$ (for 1st and IVth quadrant) Area = $2a^2 \left(\frac{\pi}{4} - \frac{2}{3}\right) = a^2 \left(\frac{\pi}{2} - \frac{4}{3}\right)$
		
(vi) $f(x, y) : x^2 = 4ay$ $y^2 = 4bx$	$O(0, 0),$ $A(4a^{2/3}b^{1/3}, 4a^{1/3}b^{2/3})$	Area = $\frac{16}{3} (ab)$ sq units
		
(vii) Area bounded by $y = c^2x^2, X$ -axis and the lines $y = a, y = b$	$O(0, 0), A\left(\frac{\sqrt{a}}{c}, a\right),$ $B\left(\frac{\sqrt{b}}{c}, b\right)$	Area = $\frac{2(b^{3/2} - a^{3/2})}{3c}$ sq unit
		

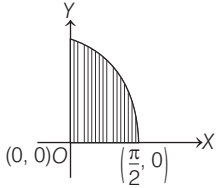
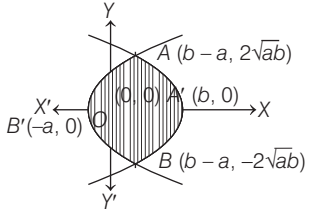
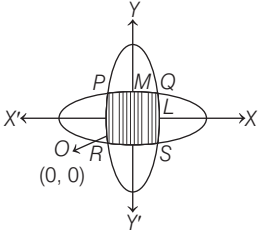
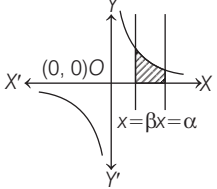
Curves	Point of intersection	Area of shaded region	
(viii) $y = k \cos 3x \forall 0 \leq x \leq \frac{\pi}{6}$	As $0 \leq x \leq \frac{\pi}{6}$ $\therefore 0 \leq 3x \leq \frac{\pi}{2}$	Area = $\frac{k}{3}$ sq unit	
(ix) Area bounded by $y^2 = 4a(x+a)$ $y^2 = 4b(b-x)$	$A(b-a, 2\sqrt{ab})$ $B(b-a, -2\sqrt{ab})$	Area = $\frac{8}{3}\sqrt{ab}(a+b)$ sq units	
(x) Common area bounded by the ellipses $\frac{x^2}{b^2} + \frac{y^2}{a^2} = \frac{1}{a^2b^2}$ and $\frac{x^2}{a^2} + \frac{y^2}{b^2} = \frac{1}{a^2b^2}$ , $0 < a < b$	$\left( \pm \frac{1}{\sqrt{a^2 + b^2}}, \pm \frac{1}{\sqrt{a^2 + b^2}} \right)$	Area = Area of PQRS = 4 × Area of OLQM = $\frac{4}{ab} \tan^{-1} \left( \frac{a}{b} \right)$ sq unit	
(xi) If $\alpha, \beta > 0, \alpha > \beta$ , the area between the hyperbola $xy = p^2$ , the X-axis and the abscissa $x = \alpha, x = \beta$		Area = $p^2 \log \left( \frac{\alpha}{\beta} \right)$	

# Practice Exercise

## ROUND I Topically Divided Problems

### Area between a Curve and Axis

1. The area of the region bounded by  $y^2 = 9x$ ,  $x = 2$ ,  $x = 4$  and the  $X$ -axis in the first quadrant is

- (a) 16 sq units (b)  $4\sqrt{2}$  sq units  
(c)  $4(4 - \sqrt{2})$  sq units (d)  $4(4 + \sqrt{2})$  sq units

2. The area between  $x = y^2$  and  $x = 4$  is divided into two equal parts by the line  $x = a$ , the value of  $a$  is

- (a)  $(2)^{2/3}$  (b)  $\sqrt{2}$  (c)  $(4)^{4/3}$  (d)  $(4)^{2/3}$

3. The area of the region bounded by the curve  $y^2 = 4x$  and the line  $x = 3$  is

- (a)  $2\sqrt{3}$  sq units (b)  $8\sqrt{3}$  sq units  
(c)  $4\sqrt{3}$  sq units (d)  $3\sqrt{3}$  sq units

4. Area lying in the first quadrant and bounded by the circle  $x^2 + y^2 = 4$  and the lines  $x = 0$  and  $x = 2$  is

- (a)  $\pi$  sq units (b)  $\frac{\pi}{2}$  sq units  
(c)  $\frac{\pi}{3}$  sq units (d)  $\frac{\pi}{4}$  sq units

5. The area (in sq units) of the region

$$A = \{(x, y) \in R \times R \mid 0 \leq x \leq 3, 0 \leq y \leq 4, y \leq x^2 + 3x\}$$

(JEE Main 2019)

- (a)  $\frac{53}{6}$  (b) 8 (c)  $\frac{59}{6}$  (d)  $\frac{26}{3}$

6. The area bounded by the curve  $y = x|x|$ ,  $X$ -axis and the coordinates  $x = -1$  and  $x = 1$  is given by

- (a) 0 (b)  $\frac{1}{3}$  (c)  $\frac{2}{3}$  (d)  $\frac{4}{3}$

7. The region represented by  $|x - y| \leq 2$  and  $|x + y| \leq 2$  is bounded by a

(JEE Main 2019)

- (a) rhombus of side length 2 units  
(b) rhombus of area  $8\sqrt{2}$  sq units  
(c) square of side length  $2\sqrt{2}$  units  
(d) square of area 16 sq units

8. Draw a rough sketch of the curve  $y = \sqrt{x-1}$  in the interval  $[1, 5]$ . The area under the curve and between the lines  $x = 1$  and  $x = 5$  is

- (a)  $\frac{4}{3}$  sq units (b)  $\frac{8}{3}$  sq units  
(c)  $\frac{16}{3}$  sq units (d) None of these

9. The area of the region bounded by the curve  $ay^2 = x^3$ , the  $Y$ -axis and the lines  $y = a$  and  $y = 2a$  is

- (a)  $\frac{3}{5} a^2 |2 \cdot 2^{2/3} - 1|$  sq unit  
(b)  $\frac{2}{5} a |2^{2/3} - 1|$  sq unit  
(c)  $\frac{3}{5} a^2 |2^{2/3} + 1|$  sq unit  
(d) None of the above

10. The area bounded by the curve  $x = 2 - y - y^2$  and  $Y$ -axis is

- (a)  $\frac{3}{2}$  sq units (b)  $\frac{5}{2}$  sq units  
(c)  $\frac{9}{2}$  sq units (d) None of these

11. The area bounded by the curve  $|x| + y = 1$  and axis of  $X$  is

- (a) 1 sq unit (b) 2 sq units  
(c) 8 sq units (d) None of these

12. The area of the region bounded by the curve  $xy - 3x - 2y - 10 = 0$ ,  $X$ -axis and the lines  $x = 3$ ,  $x = 4$ , is

- (a) 3 sq units  
(b)  $3 + 16 \log 2$  sq units  
(c)  $16 \log 2$  sq units  
(d) None of the above

13. The area included between the curves  $y = \frac{1}{x^2 + 1}$  and  $X$ -axis is

- (a)  $\frac{\pi}{2}$  sq units (b)  $\pi$  sq units  
(c)  $2\pi$  sq units (d) None of these

14. The area bounded by  $x = 1$ ,  $x = 2$ ,  $xy = 1$  and  $X$ -axis is

- (a)  $(\log 2)$  sq unit (b) 2 sq units  
(c) 1 sq unit (d) None of these

15. The area between the curve  $y = 4 + 3x - x^2$  and  $X$ -axis is

- (a)  $125/6$  sq units (b)  $125/3$  sq units  
(c)  $125/2$  sq units (d) None of these

16. The area bounded by the curves  $f(x) = ce^x$  ( $c > 0$ ), the  $X$ -axis and the two abscissa  $x = p$  and  $x = q$ , is proportional to

- (a)  $f(p)f(q)$  (b)  $|f(p) - f(q)|$   
(c)  $f(p) + f(q)$  (d)  $\sqrt{f(p)f(q)}$

17. If the area above  $X$ -axis, bounded by the curves  $y = 2^{kx}$  and  $x = 0$  and  $x = 2$  is  $\frac{3}{\log 2}$ , then the value

- of  $k$  is  
(a)  $1/2$  (b)  $1$  (c)  $-1$  (d)  $2$

18. The area bounded by  $y = \sin^{-1} x$ ,  $x = \frac{1}{\sqrt{2}}$  and  $X$ -axis is

- (a)  $\left(\frac{1}{\sqrt{2}} + 1\right)$  sq unit (b)  $\left(1 - \frac{1}{\sqrt{2}}\right)$  sq unit  
(c)  $\frac{\pi}{4\sqrt{2}}$  sq unit (d)  $\left(\frac{\pi}{4\sqrt{2}} + \frac{1}{\sqrt{2}} - 1\right)$  sq unit

19. The area bounded by  $y = \tan^{-1} x$ ,  $x = 1$  and  $X$ -axis is

- (a)  $\left(\frac{\pi}{4} + \log \sqrt{2}\right)$  sq unit  
(b)  $\left(\frac{\pi}{4} - \log \sqrt{2}\right)$  sq unit  
(c)  $\left(\frac{\pi}{4} - \log \sqrt{2} + 1\right)$  sq unit  
(d) None of the above

20. The area bounded by the curve  $y = \sin^2 x$  and lines  $x = \frac{\pi}{2}$ ,  $x = \pi$  and  $X$ -axis is

- (a)  $\frac{\pi}{2}$  sq unit (b)  $\frac{\pi}{4}$  sq unit  
(c)  $\frac{\pi}{8}$  sq unit (d) None of these

21. The area bounded by the curve  $y = \sec^2 x$ ,  $y = 0$  and  $|x| = \frac{\pi}{3}$  is

- (a)  $\sqrt{3}$  sq units (b)  $\sqrt{2}$  sq units  
(c)  $2\sqrt{3}$  sq units (d) None of these

22. Area enclosed between the curve  $y^2(2a - x) = x^3$  and line  $x = 2a$  above  $X$ -axis is

- (a)  $\pi a^2$  sq units (b)  $\frac{3\pi a^2}{2}$  sq units  
(c)  $2\pi a^2$  sq units (d)  $3\pi a^2$  sq units

23. The area bounded by the curve

$4y^2 = x^2(4 - x)(x - 2)$  is equal to (JEE Main 2021)

- (a)  $\frac{\pi}{8}$  (b)  $\frac{3\pi}{8}$  (c)  $\frac{3\pi}{2}$  (d)  $\frac{\pi}{16}$

24. The area bounded by  $y = x^3 - 4x$  and  $X$ -axis is

- (a) 5 sq units (b) 9 sq units  
(c) 8 sq units (d) 12 sq units

25. The area bounded by the curve  $y = \log_e x$ , the  $X$ -axis and the straight line  $x = e$  is

- (a)  $e$  sq unit (b) 1 sq unit  
(c)  $1 - \frac{1}{e}$  sq unit (d)  $1 + \frac{1}{e}$  sq unit

26. The ratio of the areas between the curves  $y = \cos 2x$  and  $y = \cos x$  and  $X$ -axis from  $x = 0$  to  $x = \frac{\pi}{3}$  is

- (a) 1 : 2 (b) 2 : 1  
(c)  $\sqrt{3} : 1$  (d) None of these

## Area between the Given Curves

27. For  $a > 0$ , let the curves  $C_1 : y^2 = ax$  and  $C_2 : x^2 = ay$  intersect at origin  $O$  and a point  $P$ . Let the line  $X = b$  ( $0 < b < a$ ) intersect the chord  $OP$  and the  $X$ -axis at points  $Q$  and  $R$ , respectively. If the line  $x = b$  bisects the area bounded by the curves,  $C_1$  and  $C_2$ , and the area of  $\Delta OQR = \frac{1}{2}$ , then 'a' satisfies the

equation (JEE Main 2020)

- (a)  $x^6 + 6x^3 - 4 = 0$  (b)  $x^6 - 12x^3 + 4 = 0$   
(c)  $x^6 - 6x^3 + 4 = 0$  (d)  $x^6 - 12x^3 - 4 = 0$

28. The area (in sq units) of the region

$\{(x, y) \in R^2 : x^2 \leq y \leq 3 - 2x\}$ , is (JEE Main 2020)

- (a)  $\frac{31}{3}$  (b)  $\frac{32}{3}$  (c)  $\frac{29}{3}$  (d)  $\frac{34}{3}$

29. Given,  $f(x) = \begin{cases} x & , 0 \leq x < \frac{1}{2} \\ \frac{1}{2} & , x = \frac{1}{2} \\ 1 - x & , \frac{1}{2} < x \leq 1 \end{cases}$

$g(x) = \left(x - \frac{1}{2}\right)^2$ ,  $x \in R$ . Then, the area in sq units of

the region bounded by the curves  $y = f(x)$  and  $y = g(x)$  between the lines,  $2x = 1$  and  $2x = \sqrt{3}$  is (JEE Main 2020)

- (a)  $\frac{1}{2} + \frac{\sqrt{3}}{4}$  (b)  $\frac{1}{3} + \frac{\sqrt{3}}{4}$  (c)  $\frac{1}{2} - \frac{\sqrt{3}}{4}$  (d)  $\frac{\sqrt{3}}{4} - \frac{1}{3}$

30. The area (in sq units) of the region

$A = \{(x, y) : x^2 \leq y \leq x + 2\}$  is (JEE Main 2019)

- (a)  $\frac{13}{6}$  (b)  $\frac{9}{2}$  (c)  $\frac{31}{6}$  (d)  $\frac{10}{3}$

31. The area (in sq units) of the region

$$A = \left\{ (x, y) : \frac{y^2}{2} \leq x \leq y + 4 \right\} \text{ is} \quad (\text{JEE Main 2019})$$

- (a) 30      (b)  $\frac{53}{3}$       (c) 16      (d) 18

32. The area (in sq units) of the region bounded by the curves  $y = 2^x$  and  $y = |x + 1|$ , in the first quadrant is

(JEE Main 2019)

- (a)  $\frac{3}{2}$       (b)  $\log_e 2 + \frac{3}{2}$       (c)  $\frac{1}{2}$       (d)  $\frac{3}{2} - \frac{1}{\log_e 2}$

33. If the area (in sq units) of the region

$$\{(x, y) : y^2 \leq 4x, x + y \leq 1, x \geq 0, y \geq 0\} \text{ is } a\sqrt{2} + b,$$

then  $a - b$  is equal to (JEE Main 2019)

- (a)  $\frac{10}{3}$       (b) 6      (c)  $\frac{8}{3}$       (d)  $-\frac{2}{3}$

34. If the area (in sq units) bounded by the parabola  $y^2 = 4\lambda x$  and the line  $y = \lambda x$ ,  $\lambda > 0$ , is  $\frac{1}{9}$ , then  $\lambda$  is

equal to (JEE Main 2019)

- (a)  $2\sqrt{6}$       (b) 48      (c) 24      (d)  $4\sqrt{3}$

35. The area (in sq units) bounded by the parabola  $y = x^2 - 1$ , the tangent at the point (2, 3) to it and the Y-axis is

(JEE Main 2019)

- (a)  $\frac{8}{3}$       (b)  $\frac{56}{3}$       (c)  $\frac{32}{3}$       (d)  $\frac{14}{3}$

36. The area of the region  $A = \{(x, y) : 0 \leq y \leq x|x + 1| \text{ and } -1 \leq x \leq 1\}$  in sq units, is

(JEE Main 2019)

- (a) 2      (b)  $\frac{4}{3}$       (c)  $\frac{1}{3}$       (d)  $\frac{2}{3}$

37. If the area enclosed between the curves  $y = kx^2$  and  $x = ky^2$ , ( $k > 0$ ), is 1 sq unit. Then,  $k$  is (JEE Main 2019)

- (a)  $\sqrt{3}$       (b)  $\frac{1}{\sqrt{3}}$       (c)  $\frac{2}{\sqrt{3}}$       (d)  $\frac{\sqrt{3}}{2}$

38. The area (in sq units) of the region bounded by the curve  $x^2 = 4y$  and the straight line  $x = 4y - 2$  is

(JEE Main 2019)

- (a)  $\frac{7}{8}$       (b)  $\frac{9}{8}$       (c)  $\frac{5}{4}$       (d)  $\frac{3}{4}$

39. The area (in sq units) in the first quadrant bounded by the parabola,  $y = x^2 + 1$ , the tangent to it at the point (2, 5) and the coordinate axes is (JEE Main 2019)

- (a)  $\frac{14}{3}$       (b)  $\frac{187}{24}$       (c)  $\frac{8}{3}$       (d)  $\frac{37}{24}$

40. The area (in sq units) of the region bounded by the parabola,  $y = x^2 + 2$  and the lines,  $y = x + 1$ ,  $x = 0$  and  $x = 3$ , is (JEE Main 2019)

- (a)  $\frac{15}{2}$       (b)  $\frac{17}{4}$       (c)  $\frac{21}{2}$       (d)  $\frac{15}{4}$

41. Let  $g(x) = \cos x^2$ ,  $f(x) = \sqrt{x}$  and  $\alpha, \beta$  ( $\alpha < \beta$ ) be the roots of the quadratic equation  $18x^2 - 9\pi x + \pi^2 = 0$ . Then, the area (in sq units) bounded by the curve  $y = (g \circ f)(x)$  and the lines  $x = \alpha$ ,  $x = \beta$  and  $y = 0$ , is (JEE Main 2018)

- (a)  $\frac{1}{2}(\sqrt{3} - 1)$       (b)  $\frac{1}{2}(\sqrt{3} + 1)$   
(c)  $\frac{1}{2}(\sqrt{3} - \sqrt{2})$       (d)  $\frac{1}{2}(\sqrt{2} - 1)$

42. The area (in sq units) of the region  $\{(x, y) : x \geq 0, x + y \leq 3, x^2 \leq 4y \text{ and } y \leq 1 + \sqrt{x}\}$  is

(JEE Main 2017)

- (a)  $\frac{59}{12}$       (b)  $\frac{3}{2}$       (c)  $\frac{7}{3}$       (d)  $\frac{5}{2}$

43. The area (in sq units) of the region  $\{(x, y) : y^2 \geq 2x \text{ and } x^2 + y^2 \leq 4x, x \geq 0, y \geq 0\}$  is (JEE Main 2016)

- (a)  $\pi - \frac{4}{3}$       (b)  $\pi - \frac{8}{3}$   
(c)  $\pi - \frac{4\sqrt{2}}{3}$       (d)  $\frac{\pi}{2} - \frac{2\sqrt{2}}{3}$

44. The area (in sq units) of the region described by  $\{(x, y) : y^2 \leq 2x \text{ and } y \geq 4x - 1\}$  is (JEE Main 2015)

- (a)  $\frac{7}{32}$       (b)  $\frac{5}{64}$       (c)  $\frac{15}{64}$       (d)  $\frac{9}{32}$

45. The area (in sq units) bounded by the curves  $y = \sqrt{x}$ ,  $2y - x + 3 = 0$ , X-axis and lying in the first quadrant is (JEE Main 2013)

- (a) 9      (b) 36      (c) 18      (d)  $\frac{27}{4}$

## ROUND II Mixed Bag

### Only One Correct Option

1. The larger of the area bounded by

$$y = \cos x, y = x + 1 \text{ and } y = 0 \text{ is}$$

- (a)  $\frac{1}{2}$  sq unit      (b)  $\frac{3}{2}$  sq units  
(c) 1 sq unit      (d) 2 sq units

2. The area of the closed figure bounded by

$$y = 3 - |3 - x| \text{ and } y = \frac{6}{|x + 1|} \text{ is}$$

- (a)  $\frac{13}{2} + 6 \log 2$  sq units      (b)  $\frac{9}{2} + 6 \log 2$  sq units  
(c)  $\frac{13}{2} - 6 \log 2$  sq units      (d)  $\frac{9}{2} - 6 \log 2$  sq units

3. The region bounded by the curves

$x = \frac{1}{2}$ ,  $x = 2$ ,  $y = \log x$  and  $y = 2^x$ , then the area of this region, is

- (a)  $\frac{4}{3}$  sq units (b)  $\frac{5}{3}$  sq units  
(c)  $\frac{3}{2}$  sq units (d) None of these

4. The area of the region  $R = \{(x, y) : |x| \leq |y| \text{ and } x^2 + y^2 \leq 1\}$  is

- (a)  $\frac{3\pi}{8}$  sq units (b)  $\frac{5\pi}{8}$  sq units  
(c)  $\frac{\pi}{2}$  sq units (d)  $\frac{\pi}{8}$  sq unit

5. If  $y = f(x)$  makes positive intercepts of 2 and 1 unit on  $x$  and  $y$ -coordinates axes and encloses an area of  $\frac{3}{4}$  sq unit with the axes, then  $\int_0^2 xf'(x)dx$  is

- (a)  $\frac{3}{2}$  sq units (b) 1 sq unit  
(c)  $\frac{5}{4}$  sq units (d)  $-\frac{3}{4}$  sq unit

6. The parabola  $y^2 = 2x$  divides the circle  $x^2 + y^2 = 8$  in two parts. Then, the ratio of the areas of these parts is

- (a)  $\frac{3\pi - 2}{10\pi + 2}$  (b)  $\frac{3\pi + 2}{9\pi - 2}$   
(c)  $\frac{6\pi - 3}{11\pi - 5}$  (d)  $\frac{2\pi - 9}{9\pi + 2}$

7. The area bounded by the curve  $xy^2 = 4(2 - x)$  and  $Y$ -axis is

- (a)  $2\pi$  sq units (b)  $4\pi$  sq units  
(c)  $12\pi$  sq units (d)  $6\pi$  sq units

8. A curve  $y = f(x)$  passes through the origin and lies entirely in the first quadrant. Through any point  $P(x, y)$  on the curve, lines are drawn parallel to the coordinate axes. If the curve divides the area formed by these lines and coordinates area in  $m : n$ , then the value of  $f(x)$  is equal to

- (a)  $Cx^{m+n}$  (b)  $Cx^{m-n}$  (c)  $x^{m/n}$  (d)  $Cx^{m/n}$

9. The area bounded by parabola  $y^2 = x$  and straight line  $2y = x$  is

- (a)  $\frac{4}{3}$  sq units (b) 1 sq unit  
(c)  $\frac{2}{3}$  sq unit (d)  $\frac{1}{3}$  sq unit

10. The area of bounded region by the curve  $y = \log_e x$  and  $y = (\log_e x)^2$  is

- (a)  $3 - e$  (b)  $e - 3$   
(c)  $\frac{1}{2}(3 - e)$  (d)  $\frac{1}{2}(e - 3)$

11. The area of the region :

$R = \{(x, y) : 5x^2 \leq y \leq 2x^2 + 9\}$  is (JEE Main 2021)

- (a)  $9\sqrt{3}$  sq units (b)  $12\sqrt{3}$  sq units  
(c)  $11\sqrt{3}$  sq units (d)  $6\sqrt{3}$  sq units

12. The area enclosed between the curve  $y = \log_e(x + e)$  and the coordinate axes is

- (a) 9 sq units (b)  $27/4$  sq units  
(c) 1 sq unit (d) 18 sq units

13. The area bounded by the curve  $y = \log x$ ,  $y = \log |x|$ ,  $y = |\log x|$  and  $y = |\log |x||$  is

- (a) 4 sq units (b) 6 sq units  
(c) 10 sq units (d) None of these

14. The sine and cosine curves intersect infinitely many times giving bounded regions of equal areas. The area of one of such region is

- (a)  $\sqrt{2}$  sq units (b)  $2\sqrt{2}$  sq units  
(c)  $3\sqrt{2}$  sq units (d)  $4\sqrt{2}$  sq units

15. If a curve  $y = a\sqrt{x} + bx$  passes through the point (1, 2) and the area bounded by the curve, line  $x = 4$  and  $X$ -axis is 8 sq units, then

- (a)  $a = 3, b = -1$  (b)  $a = 3, b = 1$   
(c)  $a = -3, b = 1$  (d)  $a = -3, b = -1$

16. Let  $y$  be the function which passes through (1, 2) having slope  $(2x + 1)$ . The area bounded between the curve and  $X$ -axis is

- (a) 6 sq units (b)  $\frac{5}{6}$  sq unit  
(c)  $\frac{1}{6}$  sq unit (d) None of these

17. The area between the curve  $y = 2x^4 - x^2$ , the  $X$ -axis and the ordinates of two minima of the curve is

- (a)  $\frac{7}{120}$  sq unit (b)  $\frac{9}{120}$  sq unit  
(c)  $\frac{11}{120}$  sq unit (d)  $\frac{13}{120}$  sq unit

18. The area of the region bounded by  $1 - y^2 = |x|$  and  $|x| + |y| = 1$  is

- (a)  $1/3$  sq unit (b)  $2/3$  sq unit  
(c)  $4/3$  sq unit (d) 1 sq unit

19. Area bounded by the curve  $y = (x - 1)(x - 2)(x - 3)$  and  $X$ -axis lying between the ordinates  $x = 0$  and  $x = 3$  is equal to
- (a)  $\frac{9}{4}$  sq units                      (b)  $\frac{11}{4}$  sq units  
(c)  $\frac{13}{4}$  sq units                      (d)  $\frac{15}{4}$  sq units
20. If the abscissa  $x = a$  divides the area bounded by  $X$ -axis part of the curve  $y = 1 + \frac{8}{x^2}$  and the abscissa  $x = 2$ ,  $x = 4$  into two equal parts, then  $a$  is equal to
- (a)  $\sqrt{2}$  sq units  
(b)  $2\sqrt{2}$  sq units  
(c)  $3\sqrt{2}$  sq units  
(d) None of the above
21. Area bounded by the curve  $y = x \sin x$  and  $X$ -axis between  $x = 0$  and  $x = 2\pi$  is
- (a)  $2\pi$  sq units                      (b)  $3\pi$  sq units  
(c)  $4\pi$  sq units                      (d)  $5\pi$  sq units
22. Let  $f(x) = \min\{x + 1, \sqrt{1 - x}\}$ , then area bounded by  $f(x)$  and  $X$ -axis is
- (a)  $\frac{1}{6}$  sq unit                      (b)  $\frac{5}{6}$  sq unit  
(c)  $\frac{7}{6}$  sq units                      (d)  $\frac{11}{6}$  sq units
23. The area bounded by the graph  $y = |[x - 3]|$ , the  $X$ -axis and the lines  $x = -2$  and  $x = 3$  is ( $[\cdot]$  denotes the greatest integer function)
- (a) 7 sq units                      (b) 15 sq units  
(c) 21 sq units                      (d) 28 sq units
24. The value of  $c$  for which the area of the figure bounded by the curve  $y = 8x^2 - x^5$ , the straight lines  $x = 1$  and  $x = c$  and the  $X$ -axis is equal to  $\frac{16}{3}$  is
- (a) 2                      (b)  $\sqrt{8 - \sqrt{17}}$   
(c) 3                      (d) -1
25. The slope of the tangent to a curve  $y = f(x)$  at  $\{x, f(x)\}$  is  $2x + 1$ . If the curve passes through the point  $(1, 2)$ , then the area of the region bounded by the curve, the  $X$ -axis and the line  $x = 1$  is
- (a)  $\frac{5}{6}$  sq unit                      (b)  $\frac{6}{5}$  sq units  
(c)  $\frac{1}{6}$  sq unit                      (d) 6 sq units
26. The area of the region bounded by the curve  $\alpha^4 y^2 = (2a - x)x^5$  is to that of the circle whose radius is  $a$ , is given by the ratio
- (a) 4 : 5                      (b) 5 : 8                      (c) 2 : 3                      (d) 3 : 2
27. The area bounded by  $y = xe^{|x|}$  and lines  $|x| = 1$ ,  $y = 0$  is
- (a) 4 sq units                      (b) 6 sq units  
(c) 1 sq unit                      (d) 2 sq units
28. The area enclosed by the curves  $|y + x| \leq 1$ ,  $|y - x| \leq 1$  and  $2x^2 + 2y^2 = 1$  is
- (a)  $\left(2 + \frac{\pi}{2}\right)$  sq units                      (b)  $\left(2 - \frac{\pi}{2}\right)$  sq unit  
(c)  $\left(3 + \frac{\pi}{4}\right)$  sq units                      (d)  $\left(3 - \frac{\pi}{4}\right)$  sq unit
29. The area bounded by the curve  $[x] + [y] = 4$  in first quadrant is (where  $[\cdot]$  denotes the greatest integer function)
- (a) 3 sq units                      (b) 4 sq units  
(c) 5 sq units                      (d) 6 sq units
30. Let  $A_1$  be the area of the region bounded by the curves  $y = \sin x$ ,  $y = \cos x$  and  $Y$ -axis in the first quadrant. Also, let  $A_2$  be the area of the region bounded by the curves  $y = \sin x$ ,  $y = \cos x$ ,  $X$ -axis and  $x = \frac{\pi}{2}$  in the first quadrant. Then, (JEE Main 2021)
- (a)  $A_1 = A_2$  and  $A_1 + A_2 = \sqrt{2}$   
(b)  $A_1 : A_2 = 1 : 2$  and  $A_1 + A_2 = 1$   
(c)  $2A_1 = A_2$  and  $A_1 + A_2 = 1 + \sqrt{2}$   
(d)  $A_1 : A_2 = 1 : \sqrt{2}$  and  $A_1 + A_2 = 1$
31. The area of the curve enclosed by the curve  $|x + y| + |x - y| \leq 4$ ,  $|x| \leq 1$ ,  $y \geq \sqrt{x^2 - 2x + 1}$  is
- (a) 1 sq unit                      (b) 4 sq units  
(c) 2 sq units                      (d) 6 sq units
32. Area of the region bounded by the curve  $y = 25^x + 1.6$  and curve  $y = b \cdot 5^x + 4$  whose tangent at the point  $x = 1$ , makes an angle  $\tan^{-1}(40 \log 5)$  with the  $X$ -axis is
- (a)  $2 \log_5 \left(\frac{e^4}{27}\right)$                       (b)  $4 \log_5 \left(\frac{e^4}{27}\right)$   
(c)  $3 \log_5 \left(\frac{e^4}{27}\right)$                       (d) None of these
33. The area of the region bounded by the curves  $y = ex \log x$  and  $y = \frac{\log x}{ex}$  is
- (a)  $\frac{e^2 - 5}{4e}$   
(b)  $\frac{e^2 + 1}{2e}$   
(c)  $\frac{e^2}{2}$   
(d) None of the above

- 34.** The area enclosed by circle  $x^2 + y^2 = 4$ , parabola  $y = x^2 + x + 1$ , the curve  $y = \left[ \sin^2 \frac{x}{4} + \cos \frac{x}{4} \right]$  and X-axis (where  $[\cdot]$  is the greatest integer function) is
- (a)  $\left( \frac{2\pi}{3} - \frac{1}{\sqrt{3}} + \frac{1}{3} \right)$  sq unit  
 (b)  $\left( \frac{2\pi}{3} + \sqrt{3} - \frac{1}{6} \right)$  sq unit  
 (c)  $\left( \frac{\pi}{3} + \frac{1}{\sqrt{3}} - \frac{1}{6} \right)$  sq unit  
 (d) None of the above

- 35.** The area of the region satisfying and  $\max\{|x|, |y|\} \leq 2$  is
- (a)  $(14 + 2 \log 2)$  sq units  
 (b)  $2 \log 3$  sq units  
 (c)  $\left( \frac{1}{4} + \log 3 \right)$  sq unit  
 (d) None of the above

- 36.** The area bounded by the curve  $y = \int_{1/8}^{\sin^2 x} (\sin^{-1} \sqrt{t}) dt + \int_{1/8}^{\cos^2 x} (\cos^{-1} \sqrt{t}) dt$  ( $0 \leq x \leq \pi/2$ ) and the curve satisfying the differential equation  $y(x + y^3)dx = x(y^3 - x)dy$  passing through,  $(4, -2)$
- (a)  $\frac{1}{2} \left( \frac{3\pi}{16} \right)^2$  sq unit

- (b)  $\frac{3}{8} \left( \frac{3\pi}{16} \right)^4$  sq unit  
 (c)  $\frac{1}{8} \left( \frac{3\pi}{16} \right)^4$  sq unit  
 (d) None of the above

## Numerical Value Type Questions

- 37.** The parabolas  $y^2 = 4x$  and  $x^2 = 4y$  divide the square region bounded the lines  $x = 4$ ,  $y = 4$  and the coordinates axes. If  $S_1, S_2$  and  $S_3$  are respectively the areas of these parts numbered from top to bottom, then  $S_1 + S_2 + S_3 = \dots\dots\dots$
- 38.** The line  $y = mx$  bisects the area enclosed by the lines  $x = 0$ ,  $y = 0$  and  $x = \frac{3}{2}$  and the curve  $y = -x^2 + 4x + 1$ . Then, the value  $6m$  is equal to
- 39.** Area bounded by the line  $y = x$ , curve  $y = f(x)$ ,  $\{f(x) > x, \forall x > 1\}$  and the lines  $x = 1$ ,  $x = t$  is  $(t + \sqrt{1+t^2}) - (1 + \sqrt{2})$  for all  $t > 1$ . Then,  $f(0)$  is equal to
- 40.** The graphs of sine and cosine functions, intersect each other at a number of points and between two consecutive points of intersection, the two graphs enclose the same area A. Then,  $A^4$  is equal to

(JEE Main 2021)

## Answers

### Round I

1. (c)	2. (d)	3. (b)	4. (a)	5. (c)	6. (c)	7. (c)	8. (c)	9. (a)	10. (c)
11. (a)	12. (b)	13. (b)	14. (a)	15. (a)	16. (b)	17. (b)	18. (d)	19. (b)	20. (b)
21. (c)	22. (b)	23. (c)	24. (c)	25. (b)	26. (b)	27. (b)	28. (b)	29. (d)	30. (b)
31. (d)	32. (d)	33. (b)	34. (c)	35. (a)	36. (a)	37. (b)	38. (b)	39. (d)	40. (a)
41. (a)	42. (d)	43. (b)	44. (d)	45. (a)					

### Round II

1. (b)	2. (c)	3. (d)	4. (c)	5. (d)	6. (b)	7. (b)	8. (d)	9. (a)	10. (a)
11. (b)	12. (c)	13. (a)	14. (b)	15. (a)	16. (c)	17. (a)	18. (b)	19. (b)	20. (b)
21. (c)	22. (c)	23. (b)	24. (d)	25. (a)	26. (b)	27. (d)	28. (b)	29. (c)	30. (d)
31. (c)	32. (b)	33. (a)	34. (b)	35. (a)	36. (c)	37. (16)	38. (13)	39. (1)	40. (64)

# Solutions

## Round I

1. Since, the given curve  $y^2 = 9x$  is a parabola which is symmetrical about X-axis ( $\because$  the power to  $y$  is even) and passes through the origin).

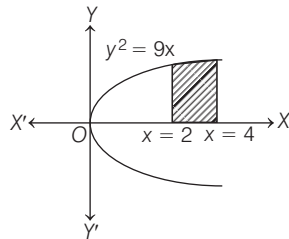

The area of the region bounded by the curve,  $y^2 = 9x$ ,  $x = 2$  and  $x = 4$  and the X-axis is the area shown in the figure.

Required area (shaded region)

$$\begin{aligned} &= \int_2^4 |y| dx = \int_2^4 3\sqrt{x} dx \quad [\because y^2 = 9x \Rightarrow |y| = 3\sqrt{x}] \\ &= 3 \left[ \frac{x^{3/2}}{3/2} \right]_2^4 = \frac{3 \times 2}{3} [4^{3/2} - 2^{3/2}] = 2 [4\sqrt{4} - 2\sqrt{2}] = 2[8 - 2\sqrt{2}] \\ &= 4[4 - \sqrt{2}] \text{ sq units} \end{aligned}$$

2. Given curve  $x = y^2$  is a parabola symmetrical about X-axis and passing through the origin.

The line  $x = a$ , divides the area bounded by the parabola and  $x = 4$  into two equal parts.

Area of  $OAD$  = Area of  $ABCD$

$\therefore$  Area of  $OED$  = Area of  $EFCD$

$$\Rightarrow \text{Area of } OED = \int_0^a y dx \text{ and area of } EFCD = \int_a^4 \sqrt{x} dx$$

$$\Rightarrow \int_0^a \sqrt{x} dx = \int_a^4 \sqrt{x} dx \Rightarrow \left[ \frac{x^{3/2}}{3/2} \right]_0^a = \left[ \frac{x^{3/2}}{3/2} \right]_a^4$$

$$\Rightarrow \frac{2}{3} [a^{3/2} - 0] = \frac{2}{3} [4^{3/2} - a^{3/2}]$$

$$\Rightarrow a^{3/2} = 4^{3/2} - a^{3/2} \Rightarrow 2a^{3/2} = 8$$

$$\Rightarrow a^{3/2} = 4 \Rightarrow a = (4)^{2/3}$$

Therefore, the value of  $a$  is  $(4)^{2/3}$ .

3. The given curve is  $y^2 = 4x$ , which represents a right hand parabola with vertex at  $(0, 0)$  and axis along X-axis and the equation of line is  $x = 3$ .

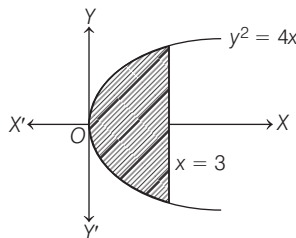

Required area

$$= 2 \times (\text{Area of shaded region in the first quadrant only})$$

$$= 2 \int_0^3 |y| dx = 2 \int_0^3 2\sqrt{x} dx \quad [\because y^2 = 4x \Rightarrow y = 2\sqrt{x}]$$

$$= 4 \left[ \frac{x^{3/2}}{3/2} \right]_0^3 = \frac{8}{3} [3^{3/2} - 0] = \frac{8}{3} (3\sqrt{3}) = 8\sqrt{3} \text{ sq units}$$

Therefore, the required area is  $8\sqrt{3}$  sq units.

4. The area bounded by the circle and the lines  $x = 0$  and  $x = 2$ , in the first quadrant is represented in the figure by shaded region.

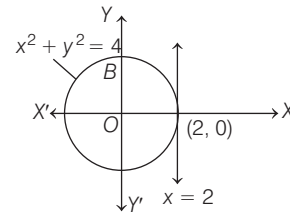

$$\text{Required area} = \int_0^2 |y| dx = \int_0^2 \sqrt{4 - x^2} dx$$

$$= \left[ \frac{x}{2} \sqrt{4 - x^2} + \frac{4}{2} \sin^{-1} \left( \frac{x}{2} \right) \right]_0^2$$

$$= 0 + 2 \sin^{-1}(1) - 0 = 2 \times \frac{\pi}{2} = \pi \text{ sq units}$$

5. (c) Given,  $y \leq x^2 + 3x$

$$\Rightarrow y \leq \left( x + \frac{3}{2} \right)^2 - \frac{9}{4} \Rightarrow \left( x + \frac{3}{2} \right)^2 \geq \left( y + \frac{9}{4} \right)$$

Since,  $0 \leq y \leq 4$

and  $0 \leq x \leq 3$

$\therefore$  The diagram for the given inequalities is

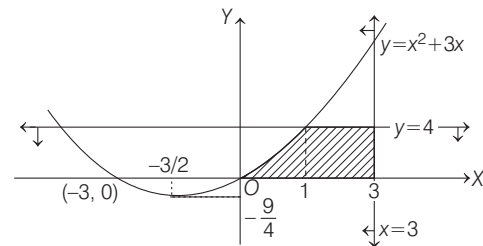

and points of intersection of curves  $y = x^2 + 3x$  and  $y = 4$  are  $(1, 4)$  and  $(-4, 4)$

$$\text{Now, required area} = \int_0^1 (x^2 + 3x) dx + \int_1^3 4 dx$$

$$= \left[ \frac{x^3}{3} + \frac{3x^2}{2} \right]_0^1 + [4x]_1^3 = \frac{1}{3} + \frac{3}{2} + 4(3 - 1)$$

$$= \frac{2}{6} + \frac{9}{6} + 8 = \frac{11}{6} + 8 = \frac{59}{6} \text{ sq units}$$

6. Given,  $y = x|x| = \begin{cases} x^2, & x \geq 0 \\ -x^2, & x < 0 \end{cases}$

Required area

= 2 [Area under the curve  $y = x^2$ , between  $x = 0, x = 1$ ]

[∵ the curve is symmetrical in opposite quadrant.]

=  $2 \int_0^1 x|x| dx = 2 \int_0^1 x^2 dx$

=  $2 \left[ \frac{x^3}{3} \right]_0^1 = \frac{2}{3} (1^3 - 0^3)$

=  $\frac{2}{3}$  sq unit

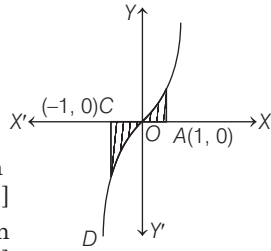

7. The given inequalities are  $|x - y| \leq 2$  and  $|x + y| \leq 2$ .

On drawing, the above inequalities, we get a square

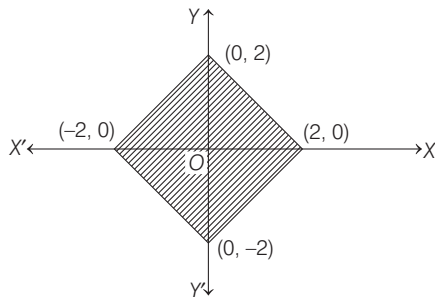

Now, the area of shaded region is equal to the area of a square having side length

$\sqrt{(2-0)^2 + (0-2)^2} = 2\sqrt{2}$  units.

8. Given equations of the curves are

$y = \sqrt{x-1}$  ... (i)

$x = 1$  ... (ii)

and

$x = 5$  ... (iii)

Eq. (i) represents the upper portion of the parabola, whose vertex is (1, 0) and axis is X-axis.

Eq. (ii) represents the line parallel to Y-axis and passes through the point (1, 0).

Eq. (iii) represents the line parallel to Y-axis and passes through the point (5, 0).

∴ Required area

=  $\int_1^5 y dx = \int_1^5 \sqrt{x-1} dx = \left[ \frac{2(x-1)^{3/2}}{3} \right]_1^5$

=  $\frac{2}{3} [(5-1)^{3/2} - (1-1)^{3/2}]$

=  $\frac{2}{3} [(4)^{3/2}] = \frac{16}{3}$  sq units

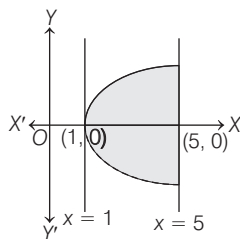

9. We have,

Area  $BMNC = \int_a^{2a} x dy$

=  $\int_a^{2a} a^{1/3} y^{2/3} dy$

=  $\frac{3a^{1/3}}{5} \left[ y^{5/3} \right]_a^{2a}$

=  $\frac{3a^{1/3}}{5} \left[ (2a)^{5/3} - a^{5/3} \right]$

=  $\frac{3}{5} a^{1/3} a^{5/3} \left[ (2)^{5/3} - 1 \right] = \frac{3}{5} a^2 \left[ 2 \cdot 2^{2/3} - 1 \right]$  sq unit

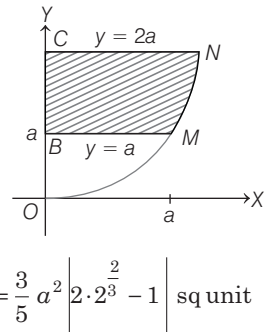

10. The required area =  $\int_{-2}^1 x dy$

=  $\int_{-2}^1 (2 - y - y^2) dy$

=  $\left[ 2y - \frac{y^2}{2} - \frac{y^3}{3} \right]_{-2}^1$

=  $\frac{9}{2}$  sq units

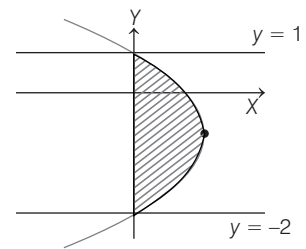

11. Given curve is  $|x| + y = 1$

∴ Curve is  $x + y = 1$ , when  $x \geq 0$

and  $-x + y = 1$ , when  $x \leq 0$

The graph of the curve is as given in the figure.

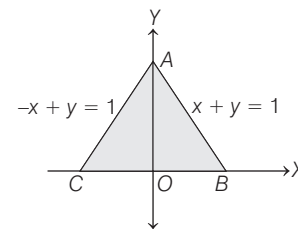

∴ Required area = Area  $CAOC$  + Area  $OABO$

=  $\int_{-1}^0 y dx + \int_0^1 y dx$

=  $\int_{-1}^0 (x+1) dx + \int_0^1 (1-x) dx$

=  $\left[ \frac{x^2}{2} + x \right]_{-1}^0 + \left[ x - \frac{x^2}{2} \right]_0^1$

=  $\left[ 0 - \left( \frac{1}{2} - 1 \right) \right] + \left[ \left( 1 - \frac{1}{2} \right) - 0 \right]$

=  $\frac{1}{2} + \frac{1}{2} = 1$  sq unit

12. The equation of the curve is

$xy - 3x - 2y - 10 = 0 \Rightarrow y = \frac{3x+10}{x-2}$

∴ Required area =  $\int_3^4 \frac{3x+10}{x-2} dx = \int_3^4 \left\{ 3 + \frac{16}{(x-2)} \right\} dx$

=  $[3x + 16 \log(x-2)]_3^4$

=  $12 + 16 \log 2 - 9 - \log 1$

=  $3 + 16 \log 2$  sq units

13. Required area =  $\int_{-\infty}^{\infty} \frac{1}{x^2 + 1} dx$

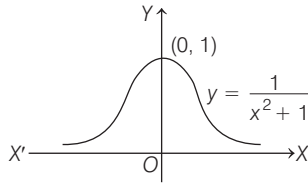

=  $2 [\tan^{-1} x]_0^{\infty} = \pi$  sq units

14. Required area =  $\int_1^2 \frac{1}{x} dx$

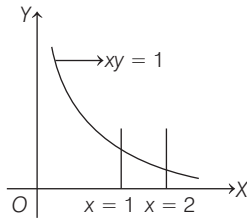

=  $[\log |x|]_1^2 = \log 2$  sq unit

15. Equation of curve are  $y = 0$  ... (i)

and  $y = 4 + 3x - x^2$  ... (ii)

On solving Eqs. (i) and (ii), we get  $x = -1, 4$

$\therefore$  Curve does not intersect X-axis between  $x = -1$  and  $x = 4$ .

$\therefore$  Required area =  $\int_{-1}^4 (4 + 3x - x^2) dx$

$$= \left[ 4x + \frac{3x^2}{2} - \frac{x^3}{3} \right]_{-1}^4$$

$$= \left[ 16 + 24 - \frac{64}{3} + 4 - \frac{3}{2} - \frac{1}{3} \right]$$

$$= 44 - \frac{65}{3} - \frac{3}{2}$$

$$= \frac{264 - 130 - 9}{6} = \frac{125}{6}$$
 sq units

16. Required area =  $\int_q^p ce^x dx$

=  $[ce^x]_q^p = c[e^p - e^q]$

=  $|f(p) - f(q)|$

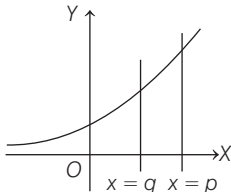

17. Area bounded by curves  $y = 2^{kx}$  and  $x = 0$  and  $x = 2$  is given by

$A = \int_0^2 2^{kx} dx = \left[ \frac{2^{kx}}{k \log 2} \right]_0^2 = \left[ \frac{2^{2k} - 1}{k \log 2} \right]$

But  $A = \frac{3}{\log 2}$

$\therefore \frac{2^{2k} - 1}{k \log 2} = \frac{3}{\log 2}$

$\Rightarrow 2^{2k} - 1 = 3k$

This relation is satisfied by only option (b).

18. Required area

= Area of rectangle  $OABC$   
- Area of curve  $OABO$

=  $\frac{\pi}{4\sqrt{2}} - \int_0^{\pi/4} \sin y dy$

=  $\frac{\pi}{4\sqrt{2}} + [\cos y]_0^{\pi/4}$

=  $\left[ \frac{\pi}{4\sqrt{2}} + \left\{ \frac{1}{\sqrt{2}} - 1 \right\} \right]$  sq units

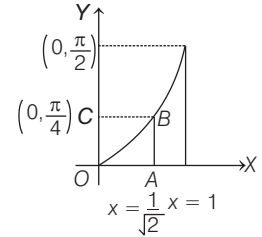

19. Required area

= Area of rectangle  $OABC$  - Area of curve  $OABO$

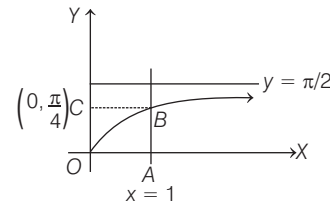

=  $\frac{\pi}{4} - \int_0^{\pi/4} \tan y dy = \frac{\pi}{4} + [\log \cos y]_0^{\pi/4}$

=  $\frac{\pi}{4} + \log \cos \frac{\pi}{4} - \log \cos(0)$

=  $\frac{\pi}{4} + \log 1 - \log \sqrt{2} - \log 1$

=  $\left( \frac{\pi}{4} - \log \sqrt{2} \right)$  sq unit

20. Required area,  $A = \int_{\pi/2}^{\pi} \sin^2 x dx$

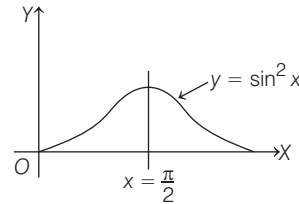

=  $\frac{1}{2} \int_{\pi/2}^{\pi} (1 - \cos 2x) dx$

=  $\frac{1}{2} \left[ x - \frac{\sin 2x}{2} \right]_{\pi/2}^{\pi}$

=  $\frac{\pi}{4}$  sq units

21. Required area =  $\int_{-\pi/3}^{\pi/3} \sec^2 x dx$

=  $[\tan x]_{-\pi/3}^{\pi/3} = 2\sqrt{3}$  sq units

22. Given equation of curve is

$$y^2(2a - x) = x^3$$

which is symmetrical about X-axis and passes through origin.

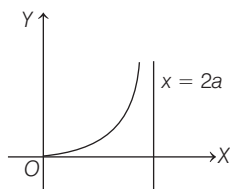

$$\text{Also, } \frac{x^3}{2a - x} < 0$$

$$\text{for } x > 2a$$

$$\text{or } x < 0$$

So, curve does not lie in  $x > 2a$  and  $x < 0$ , therefore curve lies wholly on  $0 \leq x \leq 2a$

$$\therefore \text{Required area} = \int_0^{2a} \frac{x^{3/2}}{\sqrt{2a - x}} dx$$

$$\text{Put } x = 2a \sin^2 \theta$$

$$\Rightarrow dx = 2a \cdot 2 \sin \theta \cos \theta d\theta$$

$$\therefore \text{Required area} = \int_0^{\pi/2} 8a^2 \sin^4 \theta d\theta = 8a^2 \left[ \frac{3}{4} \cdot \frac{1}{2} \cdot \frac{\pi}{2} \right]$$

[using gamma function]

$$= \frac{3\pi a^2}{2} \text{ sq units}$$

23. We have,  $4y^2 = x^2(4 - x)(x - 2)$

$$|y| = \frac{|x|}{2} \sqrt{(4 - x)(x - 2)}$$

$$\Rightarrow y_1 = \frac{x}{2} \sqrt{(4 - x)(x - 2)}$$

$$\text{and } y_2 = \frac{-x}{2} \sqrt{(4 - x)(x - 2)}$$

$$D: x \in [2, 4]$$

$$\text{Req. area} = \int_2^4 (y_1 - y_2) dx = \int_2^4 x \sqrt{(4 - x)(x - 2)} dx \dots(i)$$

$$\text{Applying } \int_a^b f(x) dx = \int_a^b (a + b - x) dx$$

$$\text{Area} = \int_2^4 (6 - x) \sqrt{(4 - x)(x - 2)} dx \dots(ii)$$

From Eqs. (i) and (ii), we get

$$2A = 6 \int_2^4 \sqrt{(4 - x)(x - 2)} dx$$

$$A = 3 \int_2^4 \sqrt{1 - (x - 3)^2} dx$$

$$A = 3 \cdot \frac{\pi}{2} \cdot 1^2 = \frac{3\pi}{2}$$

24.  $y = x(x^2 - 2^2)$

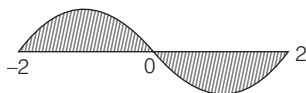

$$\Rightarrow y = x(x - 2)(x + 2)$$

$$\therefore \text{Required area} = \int_{-2}^0 (x^3 - 4x) dx + \int_0^2 |x^3 - 4x| dx$$

$$= \left[ \frac{x^4}{4} - 2x^2 \right]_{-2}^0 - \left[ \frac{x^4}{4} - 2x^2 \right]_0^2$$

$$= 8 \text{ sq units}$$

25. Required area

$$= \int_1^e \log_e x \cdot dx$$

$$= [x \log_e x - x]_1^e$$

$$= [e \log_e e - e - \log 1 + 1]$$

$$= [e - e + 1] = 1 \text{ sq unit}$$

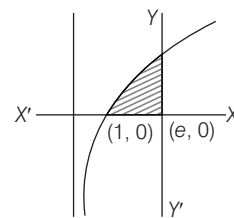

$$26. \frac{\int_0^{\pi/3} \cos x dx}{\int_0^{\pi/3} \cos 2x dx} = \frac{[\sin x]_0^{\pi/3}}{\left[ \frac{\sin 2x}{2} \right]_0^{\pi/3}} = \frac{2}{1}$$

27. Given curves  $C_1: y^2 = ax$ , and  $C_2: x^2 = ay$ , ( $a > 0$ ), intersect each other at origin  $O$  and a point  $P(a, a)$ .  
 $\therefore O(0, 0)$ ,  $Q$  and  $P(a, a)$  are collinear. So,  $Q(b, b)$ .

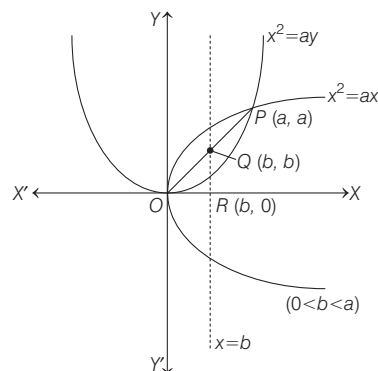

Now, as it is given area of  $\Delta OQR = \frac{1}{2}$

$$\Rightarrow \frac{1}{2} b^2 = \frac{1}{2} \Rightarrow b = 1 \quad (\because b > 0)$$

$\therefore$  The line  $x = b$  bisects the area bounded by the curves,  $C_1$  and  $C_2$ , so

$$\int_0^1 \left( \sqrt{a} \sqrt{x} - \frac{x^2}{a} \right) dx = \int_1^a \left( \sqrt{a} \sqrt{x} - \frac{x^2}{a} \right) dx$$

$$\Rightarrow \left[ \sqrt{a} \frac{x^{3/2}}{3/2} - \frac{1}{a} \frac{x^3}{3} \right]_0^1 = \left[ \sqrt{a} \frac{x^{3/2}}{3/2} - \frac{1}{a} \frac{x^3}{3} \right]_1^a$$

$$\Rightarrow \frac{2\sqrt{a}}{3} - \frac{1}{3a} = \frac{2a^2}{3} - \frac{a^2}{3} - \frac{2\sqrt{a}}{3} + \frac{1}{3a}$$

$$\Rightarrow \frac{4\sqrt{a}}{3} = \frac{a^2}{3} + \frac{2}{3a} \Rightarrow 4a\sqrt{a} = a^3 + 2$$

$$\Rightarrow 16a^3 = a^6 + 4 + 4a^3 \Rightarrow a^6 - 12a^3 + 4 = 0$$

$\therefore a$  satisfies the equation  $x^6 - 12x^3 + 4 = 0$

28. The area of the region  $\{(x, y) \in R^2 : x^2 \leq y \leq 3 - 2x\}$  is the area of region bounded by curves  $y = x^2$  and  $y = 3 - 2x$ .

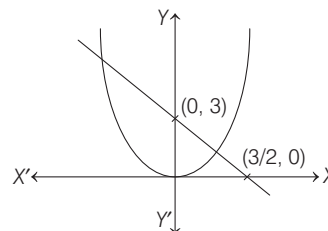

On solving  $y = 3 - 2x$  and  $y = x^2$ ,  
 we have  $x^2 = 3 - 2x \Rightarrow x^2 + 2x - 3 = 0$   
 $\Rightarrow x = -3, 1$ , then  $(x, y) = (-3, 9)$  and  $(1, 1)$

So, required area =  $\int_{-3}^1 [(3 - 2x) - x^2] dx$   
 $= \left[ 3x - \frac{2x^2}{2} - \frac{x^3}{3} \right]_{-3}^1$   
 $= \left( 3 - 1 - \frac{1}{3} \right) - (-9 - 9 + 9)$   
 $= 9 + \frac{5}{3} = \frac{32}{3}$  sq units

**29.** On drawing the given curves

$$y = f(x) = \begin{cases} x, & 0 \leq x < \frac{1}{2} \\ \frac{1}{2}, & x = \frac{1}{2} \\ 1 - x, & \frac{1}{2} < x \leq 1 \end{cases}$$

and  $y = g(x) = \left(x - \frac{1}{2}\right)^2$ , we have

Coordinate of points

$A\left(\frac{1}{2}, 0\right)$ ,  $B(1, 0)$ ,  $C\left(\frac{\sqrt{3}}{2}, 1 - \frac{\sqrt{3}}{2}\right)$  and  $D\left(\frac{1}{2}, \frac{1}{2}\right)$

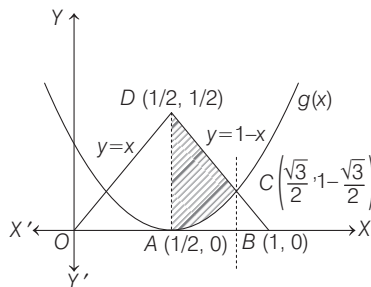

So, required area = area of shaded region

$$= \int_{\frac{1}{2}}^{\frac{\sqrt{3}}{2}} \left[ 1 - x - \left(x - \frac{1}{2}\right)^2 \right] dx$$

$$= \int_{\frac{1}{2}}^{\frac{\sqrt{3}}{2}} \left( 1 - x - x^2 + x - \frac{1}{4} \right) dx = \int_{\frac{1}{2}}^{\frac{\sqrt{3}}{2}} \left( \frac{3}{4} - x^2 \right) dx$$

$$= \left( \frac{3}{4}x - \frac{x^3}{3} \right)_{\frac{1}{2}}^{\frac{\sqrt{3}}{2}} = \frac{3\sqrt{3}}{8} - \frac{3\sqrt{3}}{24} - \frac{3}{8} + \frac{1}{24} = \left( \frac{\sqrt{3}}{4} - \frac{1}{3} \right)$$
 sq units

**30.** Given region is  $A = \{(x, y) : x^2 \leq y \leq x + 2\}$

Now, the region is shown in the following graph

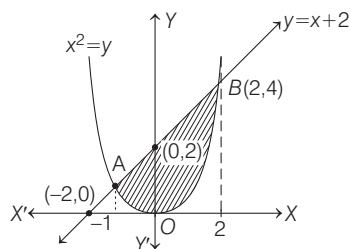

For intersecting points  $A$  and  $B$

Taking,  $x^2 = x + 2 \Rightarrow x^2 - x - 2 = 0$

$\Rightarrow x^2 - 2x + x - 2 = 0$

$\Rightarrow x(x - 2) + 1(x - 2) = 0$

$\Rightarrow x = -1, 2 \Rightarrow y = 1, 4$

So,  $A(-1, 1)$  and  $B(2, 4)$ .

Now, shaded area =  $\int_{-1}^2 [(x + 2) - x^2] dx$

$$= \left[ \frac{x^2}{2} + 2x - \frac{x^3}{3} \right]_{-1}^2 = \left( \frac{4}{2} + 4 - \frac{8}{3} \right) - \left( \frac{1}{2} - 2 + \frac{1}{3} \right)$$

$$= 8 - \frac{1}{2} - \frac{9}{3}$$

$$= 8 - \frac{1}{2} - 3 = 5 - \frac{1}{2} = \frac{9}{2}$$
 sq units

**31.** Given region  $A = \left\{ (x, y) : \frac{y^2}{2} \leq x \leq y + 4 \right\}$

$\therefore \frac{y^2}{2} = x$

$\Rightarrow y^2 = 2x$  ... (i)

and  $x = y + 4 \Rightarrow y = x - 4$  ... (ii)

Graphical representation of  $A$  is

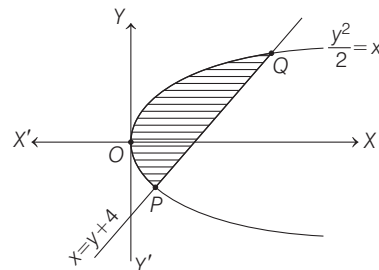

On substituting  $y = x - 4$  from Eq. (ii) to Eq. (i), we get

$$(x - 4)^2 = 2x$$

$$\Rightarrow x^2 - 8x + 16 = 2x$$

$$\Rightarrow x^2 - 10x + 16 = 0$$

$$\Rightarrow (x - 2)(x - 8) = 0$$

$$\Rightarrow x = 2, 8$$

$$\therefore y = -2, 4 \quad \text{[from Eq. (ii)]}$$

So, the point of intersection of Eqs. (i) and (ii) are

$P(2, -2)$  and  $Q(8, 4)$ .

Now, the area enclosed by the region  $A$

$$= \int_{-2}^4 \left[ (y + 4) - \frac{y^2}{2} \right] dy = \left[ \frac{y^2}{2} + 4y - \frac{y^3}{6} \right]_{-2}^4$$

$$= \left( \frac{16}{2} + 16 - \frac{64}{6} \right) - \left( \frac{4}{2} - 8 + \frac{8}{6} \right)$$

$$= 8 + 16 - \frac{32}{3} - 2 + 8 - \frac{4}{3} = 30 - 12$$

$$= 18 \text{ sq units}$$

32. (d) Given, equations of curves

$$y = 2^x \text{ and } y = |x + 1| = \begin{cases} x + 1, & x \geq -1 \\ -x - 1, & x < -1 \end{cases}$$

∴ The figure of above given curves is

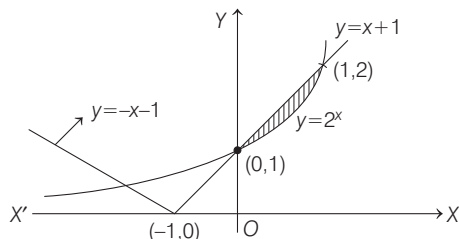

In first quadrant, the above given curves intersect each other at (1, 2).

So, the required area =  $\int_0^1 ((x + 1) - 2^x) dx$

$$\begin{aligned} &= \left[ \frac{x^2}{2} + x - \frac{2^x}{\log_e 2} \right]_0^1 \quad \left[ \because \int a^x dx = \frac{a^x}{\log_e a} + C \right] \\ &= \left[ \frac{1}{2} + 1 - \frac{2}{\log_e 2} + \frac{1}{\log_e 2} \right] = \frac{3}{2} - \frac{1}{\log_e 2} \end{aligned}$$

33. (b) Given region is  $\{(x, y) : y^2 \leq 4x, x + y \leq 1, x \geq 0, y \geq 0\}$

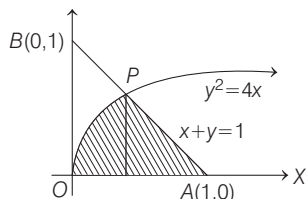

Now, for point P, put value of  $y = 1 - x$  to  $y^2 = 4x$ , we get

$$\begin{aligned} (1 - x)^2 &= 4x \Rightarrow x^2 + 1 - 2x = 4x \\ \Rightarrow x^2 - 6x + 1 &= 0 \\ \Rightarrow x &= \frac{6 \pm \sqrt{36 - 4}}{2} = 3 \pm 2\sqrt{2}. \end{aligned}$$

Since,  $x$ -coordinate of P less than  $x$ -coordinate of point A(1, 0).

$$\therefore x = 3 - 2\sqrt{2}$$

$$\text{Required area} = \int_0^{3-2\sqrt{2}} 2\sqrt{x} dx + \int_{3-2\sqrt{2}}^1 (1 - x) dx$$

$$\begin{aligned} &= 2 \left[ \frac{x^{3/2}}{3/2} \right]_0^{3-2\sqrt{2}} + \left[ x - \frac{x^2}{2} \right]_{3-2\sqrt{2}}^1 \\ &= \frac{4}{3} (3 - 2\sqrt{2})^{3/2} + \left( 1 - \frac{1}{2} \right) - (3 - 2\sqrt{2}) + \frac{(3 - 2\sqrt{2})^2}{2} \\ &= \frac{4}{3} [(\sqrt{2} - 1)^2]^{3/2} + \frac{1}{2} - 3 + 2\sqrt{2} + \frac{1}{2} (9 + 8 - 12\sqrt{2}) \\ &= \frac{4}{3} (\sqrt{2} - 1)^3 - \frac{5}{2} + 2\sqrt{2} + \frac{17}{2} - 6\sqrt{2} \\ &= \frac{4}{3} (2\sqrt{2} - 3(2) + 3(\sqrt{2}) - 1) - 4\sqrt{2} + 6 \end{aligned}$$

$$= \frac{4}{3} (5\sqrt{2} - 7) - 4\sqrt{2} + 6 = \frac{8\sqrt{2}}{3} - \frac{10}{3} = a\sqrt{2} + b \text{ (given)}$$

$$\text{So, on comparing } a = \frac{8}{3} \text{ and } b = -\frac{10}{3}$$

$$\therefore a - b = \frac{8}{3} + \frac{10}{3} = 6$$

34. (c) Given, equation of curves are

$$y^2 = 4\lambda x \quad \dots(i)$$

$$\text{and } y = \lambda x \quad \dots(ii)$$

$$\lambda > 0$$

Area bounded by above two curve is, as per figure

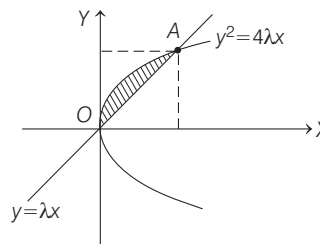

the intersection point A we will get on the solving Eqs. (i) and (ii), we get

$$\lambda^2 x^2 = 4\lambda x$$

$$\Rightarrow x = \frac{4}{\lambda}, \text{ so } y = 4$$

$$\text{So, } A \left( \frac{4}{\lambda}, 4 \right)$$

Now, required area

$$\begin{aligned} &= \int_0^{4/\lambda} (2\sqrt{\lambda x} - \lambda x) dx = 2\sqrt{\lambda} \left[ \frac{x^{3/2}}{3/2} \right]_0^{4/\lambda} - \lambda \left[ \frac{x^2}{2} \right]_0^{4/\lambda} \\ &= \frac{4}{3} \sqrt{\lambda} \frac{4\sqrt{4}}{\lambda\sqrt{\lambda}} - \frac{\lambda}{2} \left( \frac{4}{\lambda} \right)^2 = \frac{32}{3\lambda} - \frac{8}{\lambda} \\ &= \frac{32 - 24}{3\lambda} = \frac{8}{3\lambda} \end{aligned}$$

$$\text{It is given that area} = \frac{1}{9}$$

$$\Rightarrow \frac{8}{3\lambda} = \frac{1}{9}$$

$$\Rightarrow \lambda = 24$$

35. Given, equation of parabola is  $y = x^2 - 1$ , which can be rewritten as  $x^2 = y + 1$  or  $x^2 = (y - (-1))$ .

⇒ Vertex of parabola is (0, -1) and it is open upward.

Equation of tangent at (2, 3) is given by  $T = 0$

$$\Rightarrow \frac{y + y_1}{2} = x x_1 - 1 \text{ where, } x_1 = 2 \text{ and } y_1 = 3.$$

$$\Rightarrow \frac{y + 3}{2} = 2x - 1$$

$$\Rightarrow y = 4x - 5$$

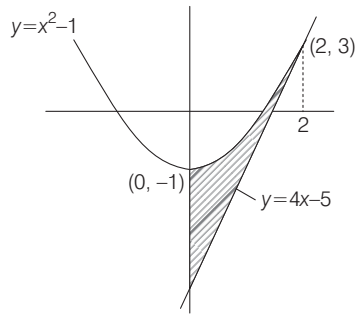

Now, required area = area of shaded region

$$\begin{aligned}
 &= \int_0^2 (y(\text{parabola}) - y(\text{tangent})) dx \\
 &= \int_0^2 [(x^2 - 1) - (4x - 5)] dx \\
 &= \int_0^2 (x^2 - 4x + 4) dx = \int_0^2 (x - 2)^2 dx \\
 &= \left| \frac{(x - 2)^3}{3} \right|_0^2 = \frac{(2 - 2)^3}{3} - \frac{(0 - 2)^3}{3} = \frac{8}{3} \text{ sq units}
 \end{aligned}$$

36. (a) We have,  $A = \{(x, y) : 0 \leq y \leq x|x| + 1 \text{ and } -1 \leq x \leq 1\}$

When  $x \geq 0$ , then  $0 \leq y \leq x^2 + 1$

and when  $x < 0$ , then  $0 \leq y \leq -x^2 + 1$

Now, the required region is the shaded region.

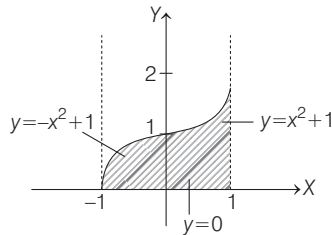

$\because y = x^2 + 1 \Rightarrow x^2 = (y - 1)$ , parabola with vertex  $(0, 1)$   
and  $y = -x^2 + 1 \Rightarrow x^2 = -(y - 1)$ ,  
parabola with vertex  $(0, 1)$  but open downward]

We need to calculate the shaded area, which is equal to

$$\begin{aligned}
 &\int_{-1}^0 (-x^2 + 1) dx + \int_0^1 (x^2 + 1) dx \\
 &= \left[ -\frac{x^3}{3} + x \right]_{-1}^0 + \left[ \frac{x^3}{3} + x \right]_0^1 \\
 &= \left( 0 - \left[ -\frac{(-1)^3}{3} + (-1) \right] \right) + \left( \left[ \frac{1}{3} + 1 \right] - 0 \right) \\
 &= -\left( \frac{1}{3} - 1 \right) + \frac{4}{3} = \frac{2}{3} + \frac{4}{3} = 2
 \end{aligned}$$

37. We know that, area of region bounded by the parabolas

$x^2 = 4ay$  and  $y^2 = 4bx$  is  $\frac{16}{3}(ab)$  sq units.

On comparing  $y = kx^2$  and  $x = ky^2$  with above equations, we get

$$4a = \frac{1}{k} \text{ and } 4b = \frac{1}{k} \Rightarrow a = \frac{1}{4k} \text{ and } b = \frac{1}{4k}$$

$\therefore$  Area enclosed between  $y = kx^2$  and  $x = ky^2$  is

$$\frac{16}{3} \left( \frac{1}{4k} \right) \left( \frac{1}{4k} \right) = \frac{1}{3k^2}$$

$$\Rightarrow \frac{1}{3k^2} = 1 \text{ [given, area = 1 sq unit]}$$

$$\Rightarrow k^2 = \frac{1}{3} \Rightarrow k = \pm \frac{1}{\sqrt{3}}$$

$$\Rightarrow k = \frac{1}{\sqrt{3}} \quad [\because k > 0]$$

38. Given equation of curve is  $x^2 = 4y$ , which represent a parabola with vertex  $(0, 0)$  and it open upward.

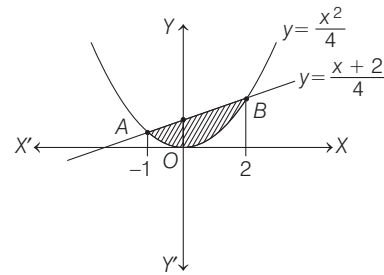

Now, let us find the points of intersection of  $x^2 = 4y$  and  $4y = x + 2$

For this consider,  $x^2 = x + 2$

$$\Rightarrow x^2 - x - 2 = 0$$

$$\Rightarrow (x - 2)(x + 1) = 0$$

$$\Rightarrow x = -1, x = 2$$

When  $x = -1$ , then  $y = \frac{1}{4}$

and when  $x = 2$ , then  $y = 1$

Thus, the points of intersection are  $A\left(-1, \frac{1}{4}\right)$  and  $B(2, 1)$ .

Now, required area = area of shaded region

$$\begin{aligned}
 &= \int_{-1}^2 \{y(\text{line}) - y(\text{parabola})\} dx \\
 &= \int_{-1}^2 \left( \frac{x+2}{4} - \frac{x^2}{4} \right) dx = \frac{1}{4} \left[ \frac{x^2}{2} + 2x - \frac{x^3}{3} \right]_{-1}^2 \\
 &= \frac{1}{4} \left[ \left( 2 + 4 - \frac{8}{3} \right) - \left( \frac{1}{2} - 2 + \frac{1}{3} \right) \right] \\
 &= \frac{1}{4} \left[ 8 - \frac{1}{2} - 3 \right] = \frac{1}{4} \left[ 5 - \frac{1}{2} \right] = \frac{9}{8} \text{ sq units}
 \end{aligned}$$

39. Given, equation of parabola is  $y = x^2 + 1$ , which can be written as  $x^2 = (y - 1)$ .

Clearly, vertex of parabola is  $(0, 1)$  and it will open upward.

Now, equation of tangent at  $(2, 5)$  is

$$\frac{y + 5}{2} = 2x + 1$$

[∴ equation of the tangent at  $(x_1, y_1)$  is given by

$$T = 0. \text{ Here, } \frac{1}{2}(y + y_1) = xx_1 + 1]$$

⇒

$$y = 4x - 3$$

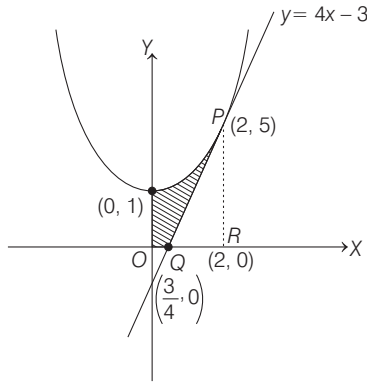

Required area = Area of shaded region

$$= \int_0^2 y(\text{parabola}) dx - (\text{Area of } \Delta PQR)$$

$$= \int_0^2 (x^2 + 1) dx - (\text{Area of } \Delta PQR)$$

$$= \left( \frac{x^3}{3} + x \right)_0^2 - \frac{1}{2} \left( 2 - \frac{3}{4} \right) \cdot 5$$

$$[\because \text{area of a triangle} = \frac{1}{2} \times \text{base} \times \text{height}]$$

$$= \left( \frac{8}{3} + 2 \right) - 0 - \frac{1}{2} \left( \frac{5}{4} \right) 5$$

$$= \frac{14}{3} - \frac{25}{8}$$

$$= \frac{112 - 75}{24} = \frac{37}{24}$$

40. Given equation of parabola is  $y = x^2 + 2$ , and the line is  $y = x + 1$

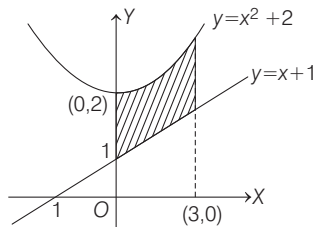

The required area = area of shaded region

$$= \int_0^3 ((x^2 + 2) - (x + 1)) dx = \int_0^3 (x^2 - x + 1) dx$$

$$= \left[ \frac{x^3}{3} - \frac{x^2}{2} + x \right]_0^3$$

$$= \left( \frac{27}{3} - \frac{9}{2} + 3 \right) - 0$$

$$= 9 - \frac{9}{2} + 3 = 12 - \frac{9}{2}$$

$$= \frac{15}{2} \text{ sq units}$$

41. We have,

$$\Rightarrow 18x^2 - 9\pi x + \pi^2 = 0$$

$$\Rightarrow 18x^2 - 6\pi x - 3\pi x + \pi^2 = 0$$

$$(6x - \pi)(3x - \pi) = 0$$

$$\Rightarrow x = \frac{\pi}{6}, \frac{\pi}{3}$$

Now,  $\alpha < \beta$

$$\therefore \alpha = \frac{\pi}{6}, \beta = \frac{\pi}{3}$$

Given,  $g(x) = \cos x^2$  and  $f(x) = \sqrt{x}$

$$y = (g \circ f)(x)$$

∴  $y = g(f(x)) = \cos x$

Area of region bounded by  $x = \alpha, x = \beta, y = 0$  and curve

$y = g(f(x))$  is

$$A = \int_{\pi/6}^{\pi/3} \cos x dx \Rightarrow A = [\sin x]_{\pi/6}^{\pi/3}$$

$$A = \sin \frac{\pi}{3} - \sin \frac{\pi}{6} = \frac{\sqrt{3}}{2} - \frac{1}{2}$$

$$A = \left( \frac{\sqrt{3} - 1}{2} \right)$$

42. Required area =  $\int_0^1 (1 + \sqrt{x}) dx + \int_1^2 (3 - x) dx - \int_0^2 \frac{x^2}{4} dx$

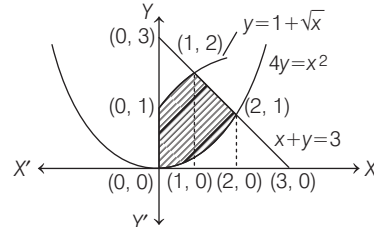

$$= \left[ x + \frac{x^{3/2}}{3/2} \right]_0^1 + \left[ 3x - \frac{x^2}{2} \right]_1^2 - \left[ \frac{x^3}{12} \right]_0^2$$

$$= \left( 1 + \frac{2}{3} \right) + \left( 6 - 2 - 3 + \frac{1}{2} \right) - \left( \frac{8}{12} \right)$$

$$= \frac{5}{3} + \frac{3}{2} - \frac{2}{3} = 1 + \frac{3}{2} = \frac{5}{2} \text{ sq units}$$

43. (b) Given equations of curves are  $y^2 = 2x$

which is a parabola with vertex  $(0, 0)$  and axis parallel to  $X$ -axis.

And  $x^2 + y^2 = 4x$  ... (i)

which is a circle with centre  $(2, 0)$  and radius

$$= 2 \quad \dots \text{(ii)}$$

On substituting  $y^2 = 2x$  in Eq. (ii), we get

$$x^2 + 2x = 4x$$

$$\Rightarrow x^2 = 2x$$

$$\Rightarrow x = 0 \text{ or } x = 2$$

$$\Rightarrow y = 0 \text{ or } y = \pm 2 \text{ [using Eq. (i)]}$$

Now, the required area is the area of shaded region, i.e.

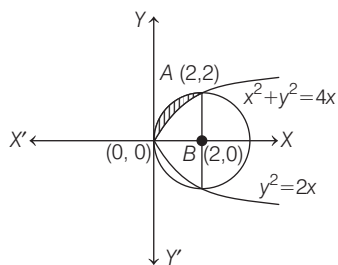

$$\begin{aligned} \text{Required area} &= \frac{\text{Area of circle}}{4} - \int_0^2 \sqrt{2x} \, dx \\ &= \frac{\pi(2)^2}{4} - \sqrt{2} \int_0^2 x^{1/2} \, dx = \pi - \sqrt{2} \left[ \frac{x^{3/2}}{3/2} \right]_0^2 \\ &= \pi - \frac{2\sqrt{2}}{3} [2\sqrt{2} - 0] = \left( \pi - \frac{8}{3} \right) \text{ sq units} \end{aligned}$$

- 44.** Given region is  $\{(x, y) : y^2 \leq 2x \text{ and } y \geq 4x - 1\}$   
 $y^2 \leq 2x$  represents a region inside the parabola  $y^2 = 2x$  ... (i)  
and  $y \geq 4x - 1$  represents a region to the left of the line  $y = 4x - 1$  ... (ii)

The point of intersection of the curve (i) and (ii) is

$$\begin{aligned} (4x - 1)^2 &= 2x \\ \Rightarrow 16x^2 + 1 - 8x &= 2x \\ \Rightarrow 16x^2 - 10x + 1 &= 0 \\ \Rightarrow x &= \frac{1}{2}, \frac{1}{8} \end{aligned}$$

$\therefore$  The points where these curves intersect, are  $\left(\frac{1}{2}, 1\right)$

and  $\left(\frac{1}{8}, -\frac{1}{2}\right)$ .

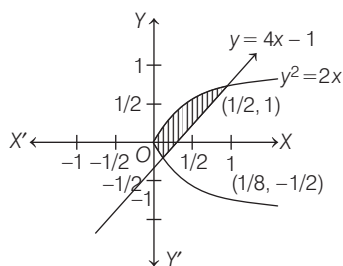

$$\begin{aligned} \text{Hence, required area} &= \int_{-1/2}^1 \left( \frac{y+1}{4} - \frac{y^2}{2} \right) dy \\ &= \frac{1}{4} \left( \frac{y^2}{2} + y \right) \Big|_{-1/2}^1 - \frac{1}{6} \left( y^3 \right) \Big|_{-1/2}^1 \\ &= \frac{1}{4} \left\{ \left( \frac{1}{2} + 1 \right) - \left( \frac{1}{8} - \frac{1}{2} \right) \right\} - \frac{1}{6} \left\{ 1 + \frac{1}{8} \right\} \\ &= \frac{1}{4} \left\{ \frac{3}{2} + \frac{3}{8} \right\} - \frac{1}{6} \left\{ \frac{9}{8} \right\} \\ &= \frac{1}{4} \times \frac{15}{8} - \frac{3}{16} = \frac{9}{32} \text{ sq units} \end{aligned}$$

- 45.** Given curves are  $y = \sqrt{x}$  ... (i)  
and  $2y - x + 3 = 0$  ... (ii)

On solving Eqs. (i) and (ii), we get

$$\begin{aligned} 2\sqrt{x} - (\sqrt{x})^2 + 3 &= 0 \\ \Rightarrow (\sqrt{x})^2 - 2\sqrt{x} - 3 &= 0 \end{aligned}$$

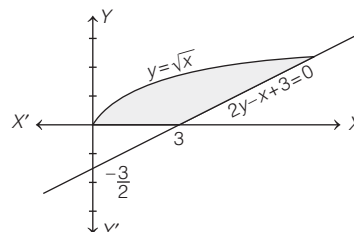

$$\begin{aligned} \Rightarrow (\sqrt{x} - 3)(\sqrt{x} + 1) &= 0 \\ \Rightarrow \sqrt{x} &= 3 \quad [\because \sqrt{x} = -1 \text{ is not possible}] \\ \therefore y &= 3 \end{aligned}$$

$$\begin{aligned} \therefore \text{Required area} &= \int_0^3 (x_2 - x_1) \, dy \\ &= \int_0^3 \{ (2y + 3) - y^2 \} \, dy \\ &= \left[ y^2 + 3y - \frac{y^3}{3} \right]_0^3 \\ &= 9 + 9 - 9 = 9 \end{aligned}$$

## Round II

- 1.**  $y = \cos x$  and  $y = x + 1$  meet at the point  $(0, 1)$   $y = x + 1$  passes through the points  $(-1, 0)$  and  $(0, 1)$  meets  $X$ -axis at  $\left(\frac{-\pi}{2}, 0\right)$  and  $\left(\frac{\pi}{2}, 0\right)$ .

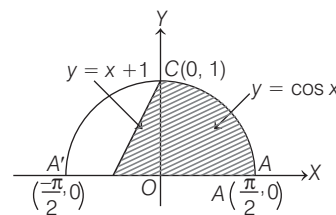

$$\begin{aligned} \therefore \text{Required area} &= \int_{-1}^0 (x+1) \, dx + \int_0^{\pi/2} \cos x \, dx \\ &= \left[ \frac{x^2}{2} + x \right]_{-1}^0 + [\sin x]_0^{\pi/2} \\ &= 0 - \left( \frac{1}{2} - 1 \right) + 1 = \frac{3}{2} \text{ sq units} \end{aligned}$$

- 2.** First consider  $y = 3 - |3 - x|$

For  $x < 3$ ,  $y = 3 - (3 - x) = x$

For  $x \geq 3$ ,  $y = 3 + 3 - x = 6 - x$

Again,  $y = \frac{6}{|x+1|}$

For  $x < -1$ ,  $y = -\frac{6}{x+1} \Rightarrow (x+1)y = -6$

For  $x > -1$ ,  $y = \frac{6}{x+1} \Rightarrow (x+1)y = 6$

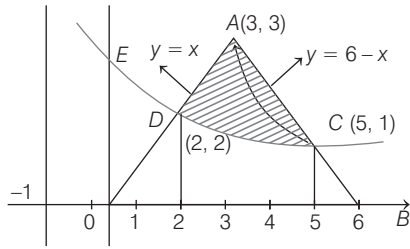

∴ Required area

= Area of shaded portion

$$= \frac{1}{2} \times 6 \times 3 - \left( \int_2^5 \frac{6}{x+1} dx + \frac{1}{2} \times 2 \times 2 + \frac{1}{2} \times 1 \times 1 \right)$$

$$= 9 - 6 \log 2 - 2 - \frac{1}{2} = \frac{13}{2} - 6 \log 2$$

3. Since, the inverse of a logarithmic function is an exponential function and *vice-versa* and these two curves are on the opposite sides of the line  $y = x$ . Thus,  $y = 2^x$  and  $y = \log x$  do not intersect. Their graphs are shown in figure. The shaded region in figure shows the area bounded by the given curves. Let us slice this region into vertical strips as shown in figure. For the approximating rectangle shown in figure, we have

length =  $(y_1 - y_2)$ , width =  $\Delta x$

area =  $(y_1 - y_2) dx$

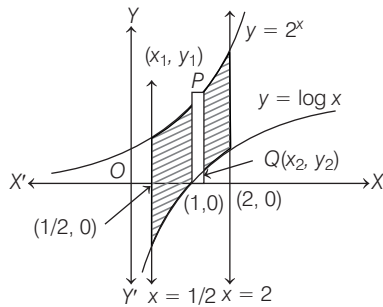

As the approximating rectangle can move horizontally between  $x = 1/2$  and 2.

∴ Required area

$$= \int_{1/2}^2 (y_1 - y_2) dx$$

$$= \int_{1/2}^2 (2^x - \log x) dx$$

$$\left[ \begin{array}{l} \because P(x_1, y_1) \text{ and } Q(x_2, y_2) \text{ lie on} \\ y = 2^x \text{ and } y = \log x, \text{ respectively.} \\ \therefore y_1 = 2^x \text{ and } y_2 = \log x \end{array} \right]$$

$$= \left[ \frac{2^x}{\log 2} - x \log x + x \right]_{1/2}^2$$

$$= \left\{ \frac{4}{\log 2} - 2 \log 2 + 2 \right\} - \left\{ \frac{\sqrt{2}}{\log 2} + \frac{1}{2} \log 2 + \frac{1}{2} \right\}$$

$$= \frac{(4 - \sqrt{2})}{\log 2} - \frac{5}{2} \log 2 + \frac{3}{2} \text{ sq units}$$

4. Required area = Area of the shaded region

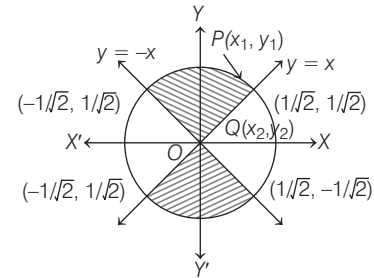

= 4 (Area of the shaded region in first quadrant)

$$= 4 \int_0^{1/\sqrt{2}} (y_1 - y_2) dx$$

$$= 4 \int_0^{1/\sqrt{2}} (\sqrt{1-x^2} - x) dx$$

$$= 4 \left[ \frac{1}{2} x \sqrt{1-x^2} + \frac{1}{2} \sin^{-1} x - \frac{x^2}{2} \right]_0^{1/\sqrt{2}}$$

$$= 4 \left[ \frac{1}{2\sqrt{2}} \times \frac{1}{\sqrt{2}} + \frac{1}{2} \times \frac{\pi}{4} - \frac{1}{4} \right] = \frac{\pi}{2} \text{ sq units}$$

5. Clearly,  $y = f(x)$  passes through  $(2, 0)$  and  $(0, 1)$ .

$$\therefore 0 = f(2) \text{ and } 1 = f(0)$$

Also,  $\int_0^2 f(x) dx = \frac{3}{4}$  (given)

Now,  $\int_0^2 x f'(x) dx = [x f(x)]_0^2 - \int_0^2 f(x) dx$

$$\Rightarrow \int_0^2 x f'(x) dx = [2f(2) - 0f(0)] - \frac{3}{4}$$

$$\Rightarrow \int_0^2 x f'(x) dx = 2 \times 0 - 0 \times 1 - \frac{3}{4} = -\frac{3}{4}$$

6. Let the area of the smaller part of circle be  $A_1$  and that of the bigger part be  $A_2$ . We have to find  $\frac{A_1}{A_2}$ .

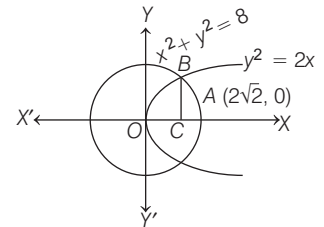

The point B is a point of intersection (lying in the first quadrant) of the given parabola and the circle, whose coordinates can be obtained by solving the two equations  $y^2 = 2x$  and  $x^2 + y^2 = 8$ .

the two equations  $y^2 = 2x$  and  $x^2 + y^2 = 8$ .

$$\Rightarrow x^2 + 2x = 8$$

$$\Rightarrow (x-2)(x+4) = 0$$

$$\Rightarrow x = 2, -4$$

$x = -4$  is not possible as both the points of intersection have the same positive  $x$ -coordinate.

Thus,  $C \equiv (2, 0)$

Now,  $A_1 = 2 [\text{Area } (OBCO) + \text{Area } (CBAC)]$

$$= 2 \left[ \int_0^2 y_1 dx + \int_2^{2\sqrt{2}} y_2 dx \right],$$

where  $y_1$  and  $y_2$  are respectively the values of  $y$  from the equations of the parabola and that of the circle.

$$\text{or } A_1 = 2 \left[ \int_0^2 \sqrt{2x} dx + \int_2^{2\sqrt{2}} \sqrt{8-x^2} dx \right]$$

$$\Rightarrow A_1 = 2 \left[ \sqrt{2} \cdot \frac{2}{3} \cdot x^{3/2} \right]_0^2 + 2 \left[ \frac{x}{2} \sqrt{8-x^2} + \frac{8}{2} \sin^{-1} \frac{x}{2\sqrt{2}} \right]_{2\sqrt{2}}$$

$$= \frac{16}{3} + 2 \left[ 2\pi + \left( 2 + 4 \times \frac{\pi}{4} \right) \right] = \left( \frac{4}{3} + 2\pi \right) \text{ sq units}$$

Area of the circle =  $\pi(2\sqrt{2})^2 = 8\pi$  sq units

Hence,  $A_2 = 8\pi - A_1 = 6\pi - \frac{4}{3}$

Then, the required ratio  $\frac{A_1}{A_2} = \frac{\frac{4}{3} + 2\pi}{6\pi - \frac{4}{3}} = \frac{2 + 3\pi}{9\pi - 2}$

7. In the equation of curve  $xy^2 = 4(2-x)$ , the degree of  $y$  is even. Therefore, the curve is symmetrical about  $X$ -axis and lies in  $0 < x \leq 2$ .

The bounded area by the curve is  $2 \int_0^2 y dx$

$$= 2 \int_0^2 2\sqrt{\frac{2-x}{x}} dx = 4 \int_0^2 \sqrt{\frac{2-x}{x}} dx$$

Put  $x = 2\sin^2 \theta$

$$\Rightarrow dx = 4 \sin \theta \cdot \cos \theta d\theta$$

$$\therefore A = 4 \int_0^{\pi/2} \sqrt{\frac{2-2\sin^2 \theta}{2\sin^2 \theta}} \cdot 4 \sin \theta \cdot \cos \theta d\theta$$

$$= 8 \int_0^{\pi/2} 2 \cos^2 \theta d\theta$$

$$= 8 \int_0^{\pi/2} (1 + \cos 2\theta) d\theta$$

$$= 8 \left[ \theta + \frac{\sin 2\theta}{2} \right]_0^{\pi/2} = 8 \left[ \frac{\pi}{2} + 0 - 0 \right] = 4\pi$$

8. Area  $(OAPB) = xy$

Area  $(OAPO) = \int_0^x f(t) dt$

Therefore, area

$(OBPO) = xy - \int_0^x f(t) dt$

According to the given condition,

$$\frac{xy - \int_0^x f(t) dt}{\int_0^x f(t) dt} = \frac{m}{n}$$

$$\Rightarrow nxy = (m+n) \int_0^x f(t) dt$$

On differentiating w.r.t.  $x$ , we get

$$n \left( x \frac{dy}{dx} + y \right) = (m+n) f(x) = (m+n)y \quad [\because y = f(x)]$$

$$\Rightarrow \frac{m}{n} \cdot \frac{dx}{x} = \frac{dy}{y}$$

$$\Rightarrow \frac{m}{n} \cdot \ln x = \ln y - \ln C, \text{ where } C \text{ is a constant}$$

$$\Rightarrow y = Cx^{m/n} \Rightarrow f(x) = Cx^{m/n}$$

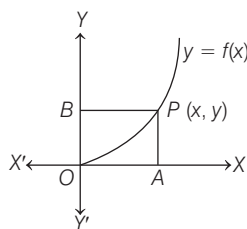

9. Given curves are  $y^2 = x$  and  $2y = x$

$$\Rightarrow y^2 + 2y \Rightarrow y = 0, 2$$

$$\therefore A = \left| \int_0^2 (y^2 - 2y) dy \right| = \left| \left[ \frac{y^3}{3} - y^2 \right]_0^2 \right| = \frac{4}{3} \text{ sq units}$$

10. Area  $A = \int_1^e [\log x - (\log x)^2] dx$

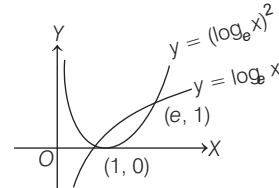

$$A = \int_1^e \log x dx - \int_1^e (\log x)^2 dx$$

$$= [x \log x - x]_1^e - [x (\log x)^2 - 2(x \log x - x)]_1^e$$

$$= [e - e - (-1)] - [e(1)^2 - 2e + 2e - (2)] = 1 - (e - 2) = 3 - e$$

- 11.

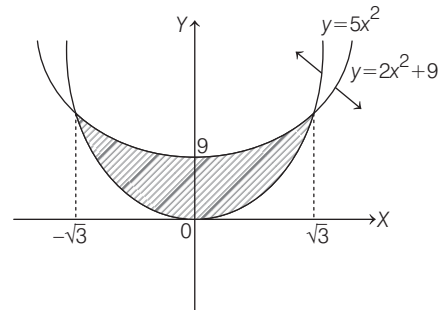

$$\text{Required area} = 2 \int_0^{\sqrt{3}} (2x^2 + 9 - 5x^2) dx$$

$$= 2 \int_0^{\sqrt{3}} (9 - 3x^2) dx$$

$$= 2 [9x - x^3]_0^{\sqrt{3}} = 12\sqrt{3}$$

12.  $A = \int_{1-e}^0 \log_e(x+e) dx$

$$= \int_1^e \log t dt \quad (\text{put } x+e=t)$$

$$= [t \log t - t]_1^e = 1 \text{ sq unit}$$

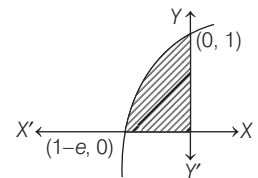

13.  $\log x$  is defined for  $x > 0$

$$|\log x| \geq 0 \text{ and } |\log |x|| \geq 0$$

$$\therefore A = 4 \int_0^1 |\log x| dx = -4 \int_0^1 \log x dx$$

$$= -4 [x \log x - x]_0^1$$

$$= -4(-1) = 4 \text{ sq units}$$

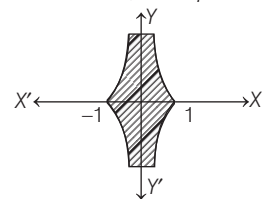

- 14.

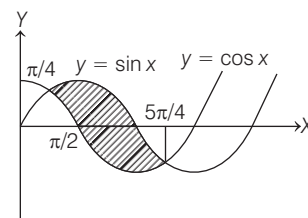

Intersection points of curves

$$y = \sin x, y = \cos x \text{ are } \left(\frac{\pi}{4}, \frac{5\pi}{4}\right), \dots$$

Since,  $\sin x \geq \cos x$  on  $\left[\frac{\pi}{4}, \frac{5\pi}{4}\right]$

$$A = \int_{\pi/4}^{5\pi/4} (\sin x - \cos x) dx$$

$$= -[\cos x + \sin x]_{\pi/4}^{5\pi/4} = 2\sqrt{2} \text{ sq units}$$

15. Since,  $y = a\sqrt{x} + bx$  passes through (1, 2).

$$\therefore 2 = a + b \quad \dots(i)$$

Area bounded by this curve and line  $x = 4$  and  $X$ -axis is 8 sq units.

$$\text{Then, } \int_0^4 (a\sqrt{x} + bx) dx = 8$$

$$\Rightarrow \frac{2a}{3} [x^{3/2}]_0^4 + \frac{b}{2} [x^2]_0^4 = 8$$

$$\Rightarrow \frac{2a}{3} \cdot 8 + 8b = 8 \Rightarrow 2a + 3b = 3 \quad \dots(ii)$$

$\therefore$  From Eqs. (i) and (ii), we get

$$a = 3$$

and

$$b = -1$$

16.  $\frac{dy}{dx} = 2x + 1$

$$\Rightarrow y = x^2 + x + c$$

$$\Rightarrow y = x^2 + x \quad (c = 0, \text{ put } x = 1, y = 2)$$

$$\therefore \left(x + \frac{1}{2}\right)^2 = y + \frac{1}{4}$$

which is equation of parabola

having vertex  $V\left(-\frac{1}{2}, -\frac{1}{4}\right)$ .

$$A = \left| \int_{-1}^0 (x^2 + x) dx \right|$$

$$= \left[ \frac{x^3}{3} + \frac{x^2}{2} \right]_{-1}^0 = \frac{1}{6} \text{ sq unit}$$

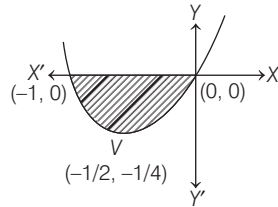

17.  $\therefore y = 2x^4 - x^2 \therefore \frac{dy}{dx} = 8x^3 - 2x$

For maxima or minima, put  $\frac{dy}{dx} = 0$ , we get  $x = -\frac{1}{2}, 0, \frac{1}{2}$

$$\text{Then, } \left(\frac{d^2y}{dx^2}\right)_{x=\frac{1}{2}} > 0, \left(\frac{d^2y}{dx^2}\right)_{x=0} < 0$$

$$\therefore \text{Required area} = \left| \int_{-1/2}^{1/2} (2x^4 - x^2) dx \right| = \frac{7}{120} \text{ sq unit}$$

18. Since,  $|x| + |y| = 1$

$$\Rightarrow \begin{cases} x + y = 1, & x > 0, y > 0 \\ x - y = 1, & x > 0, y < 0 \\ -x + y = 1, & x < 0, y > 0 \\ -x - y = 1, & x < 0, y < 0 \end{cases}$$

and  $1 - y^2 = |x|$

$$\Rightarrow \begin{cases} 1 - y^2 = x, & x \geq 0 \\ 1 - y^2 = -x, & x < 0 \end{cases}$$

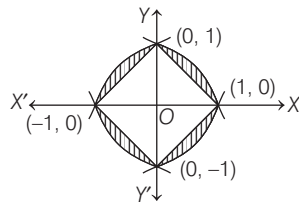

$\therefore$  Required area

$$= \left| 2 \int_0^1 \sqrt{1-x} dx \right| + \left| 2 \int_{-1}^0 \sqrt{x+1} dx \right| - 4 \left( \frac{1}{2} \cdot 1 \cdot 1 \right)$$

$$= \frac{2}{3} \text{ sq unit}$$

19. Required area

$$= \left| \int_0^1 (x-1)(x-2)(x-3) dx \right|$$

$$+ \left| \int_1^2 (x-1)(x-2)(x-3) dx \right|$$

$$+ \left| \int_2^3 (x-1)(x-2)(x-3) dx \right|$$

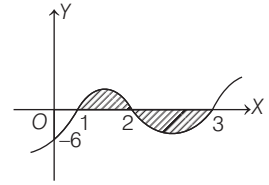

$$= \frac{9}{4} + \frac{1}{4} + \frac{1}{4} = \frac{11}{4} \text{ sq units}$$

20. Area =  $\int_2^4 \left(1 + \frac{8}{x^2}\right) dx$

Since, the ordinate  $x = a$  divides area into two equal parts, therefore

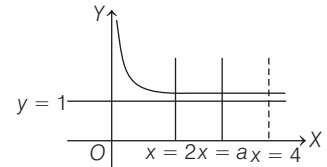

$$\int_2^a \left(1 + \frac{8}{x^2}\right) dx = \frac{1}{2} \int_2^4 \left(1 + \frac{8}{x^2}\right) dx$$

$$\Rightarrow \left[ x - \frac{8}{x} \right]_2^a = \frac{1}{2} \left[ x - \frac{8}{x} \right]_2^4$$

$$\Rightarrow \left( a - \frac{8}{a} \right) - (2 - 4) = \frac{1}{2} [(4 - 2) - (2 - 4)]$$

$$\Rightarrow a - \frac{8}{a} + 2 = 2 \Rightarrow a = \sqrt{8} = 2\sqrt{2} \text{ sq units}$$

21. Required area =  $\int_0^\pi x \sin x dx + \left| \int_\pi^{2\pi} x \sin x dx \right|$

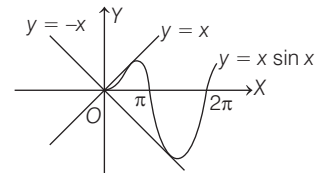

$$= \{-x \cos x + \sin x\}_0^\pi + \left| \{-x \cos x + \sin x\}_{\pi}^{2\pi} \right|$$

$$= (\pi + 0) - (0 + 0) + \left| (-2\pi + 0) - (\pi + 0) \right|$$

$$= \pi + 3\pi = 4\pi \text{ sq units}$$

22.  $f(x) = \min \{x + 1, \sqrt{1-x}\} = \begin{cases} x + 1, & -1 \leq x < 0 \\ \sqrt{1-x}, & 0 < x \leq 1 \end{cases}$

$$\therefore \text{Required area} = \left| \int_{-1}^0 (x+1) dx \right| + \left| \int_0^1 \sqrt{1-x} dx \right|$$

$$= \frac{7}{6} \text{ sq units}$$

23. Required area =  $\int_{-2}^3 |[x-3]| dx$

$$= \int_{-2}^{-1} |[x-3]| dx + \int_{-1}^0 |[x-3]| dx$$

$$+ \int_0^1 |[x-3]| dx + \int_1^2 |[x-3]| dx + \int_2^3 |[x-3]| dx$$

$$= \int_{-2}^{-1} 5 \cdot dx + \int_{-1}^0 4 \cdot dx + \int_0^1 3 \cdot dx + \int_1^2 2 \cdot dx + \int_2^3 1 \cdot dx$$

$$= 5(1) + 4(1) + 3(1) + 2(1) + 1(1) = 15 \text{ sq units}$$

24. For  $c < 1$ ,  $\int_c^1 (8x^2 - x^5) dx = \frac{16}{3}$

$$\Rightarrow \frac{8}{3} - \frac{1}{6} - \frac{8c^3}{3} + \frac{c^6}{6} = \frac{16}{3}$$

$$\Rightarrow c^3 \left[ -\frac{8}{3} + \frac{c^3}{6} \right] = \frac{16}{3} - \frac{8}{3} + \frac{1}{6} = \frac{17}{6}$$

$\Rightarrow c = -1$  satisfy the above equation.

For  $c \geq 1$ , none of the values of  $c$  satisfy the required condition that

$$\int_1^c (8x^2 - x^5) dx = \frac{16}{3}$$

25. We have,  $\frac{dy}{dx} = 2x + 1$

$\Rightarrow y = x^2 + x + c$ , it passes through (1, 2)

$\therefore c = 0$

Then,  $y = x^2 + x$

$\therefore$  Required area =  $\int_0^1 (x^2 + x) dx = \frac{5}{6}$  sq units

26. Given curve  $a^4 y^2 = (2a - x)x^5$

Cut-off X-axis, when  $y = 0$

$$0 = (2a - x)x^5 \therefore x = 0, 2a$$

Hence, the area bounded by the curve

$$a^4 y^2 = (2a - x)x^5 \text{ is}$$

$$A_1 = \int_0^{2a} \frac{\sqrt{(2a-x)x^5}}{a^2} dx$$

Put  $x = 2a \sin^2 \theta$

$\therefore dx = 4a \sin \theta \cos \theta d\theta$

$$\begin{aligned} \therefore A_1 &= \int_0^{\pi/2} \frac{\sqrt{2a} \cos \theta (2a)^{5/2} \sin^5 \theta \cdot 4a \sin \theta \cos \theta}{a^2} d\theta \\ &= 32a^2 \int_0^{\pi/2} \sin^6 \theta \cos^2 \theta d\theta \\ &= 32a^2 \cdot \frac{(5 \cdot 3 \cdot 1)(1)}{8 \cdot 6 \cdot 4 \cdot 2} \cdot \frac{\pi}{2} \quad [\text{by walli's formula}] \\ &= \frac{5\pi a^2}{8} \end{aligned}$$

Area of circle,

$$A_2 = \pi a^2$$

$\therefore \frac{A_1}{A_2} = \frac{5}{8}$

$\Rightarrow A_1 : A_2 = 5 : 8$

27. Since,  $|x| = 1$

$\therefore x = \pm 1$

$$y = xe^{|x|} = \begin{cases} xe^{-x}, & -1 < x < 0 \\ xe^x, & 0 \leq x < 1 \end{cases}$$

$\therefore$  Required area =  $\left| \int_{-1}^0 xe^{-x} dx \right| + \left| \int_0^1 xe^x dx \right|$

$$= | \{-xe^{-x} - e^{-x}\}_{-1}^0 | + | \{xe^x - e^x\}_0^1 |$$

$$= 2 \text{ sq units}$$

28. Area of the square  $ABCD = 2$  sq units

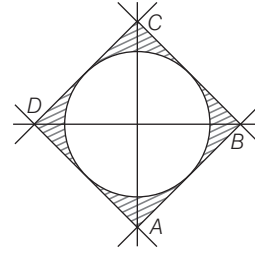

Area of the circle =  $\pi \times \frac{1}{2} = \frac{\pi}{2}$  sq units

Required area =  $\left( 2 - \frac{\pi}{2} \right)$  sq unit

29. 5 sq units.

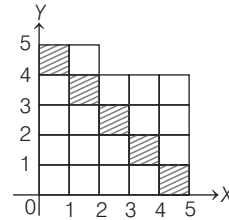

30.  $A_1 + A_2 = \int_0^{\pi/2} \cos x \cdot dx = \sin x \Big|_0^{\pi/2} = 1$

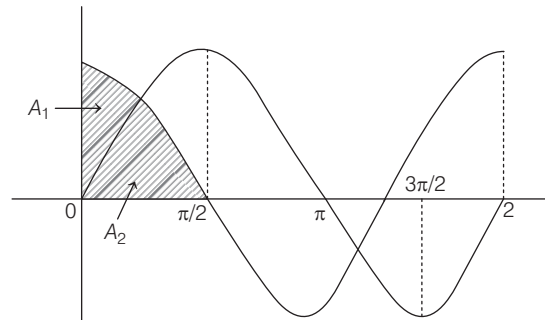

$$A_1 = \int_0^{\pi/4} (\cos x - \sin x) dx = |(\sin x + \cos x)|_0^{\pi/4} = \sqrt{2} - 1$$

$\therefore A_2 = 1 - (\sqrt{2} - 1) = 2 - \sqrt{2}$

$\therefore \frac{A_1}{A_2} = \frac{\sqrt{2} - 1}{\sqrt{2}(\sqrt{2} - 1)} = \frac{1}{\sqrt{2}}$

31. Required area =  $\frac{1}{2} \times 2 \times 2 = 2$  sq units

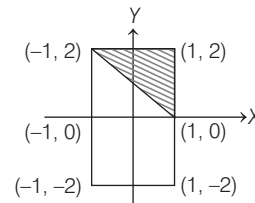

32. For  $x = 1$ ,  $y = b \cdot 5^x + 4 = 5b + 4$  and  $\frac{dy}{dx} = b \cdot 5^x \log 5$

$\Rightarrow 5b \log 5 = 40 \log 5 \Rightarrow b = 8$

The two curves intersect at points where

$$\begin{aligned} & 8 \cdot 5^x + 4 = 25^x + 16 \\ \Rightarrow & 5^{2x} - 8 \cdot 5^x + 12 = 0 \\ \Rightarrow & x = \log_5 2, x \log_5 6 \end{aligned}$$

Hence, the area of the given region

$$\begin{aligned} &= \int_{\log_5 2}^{\log_5 6} \{8 \cdot 5^x + 4 - (25^x + 16)\} dx \\ &= \int_{\log_5 2}^{\log_5 6} (8 \cdot 5^x - 25^x - 12) dx \\ &= \left[ \frac{8 \cdot 5^x}{\log_e 5} - 12x - \frac{25^x}{\log_e 25} \right]_{\log_5 2}^{\log_5 6} \\ &= \frac{-5^{\log_5 36}}{\log_e 25} + \frac{8 \cdot 5^{\log_5 6}}{\log_e 5} \\ &\quad - 12(\log_5 6 - \log_5 2) + \frac{5^{\log_5 4}}{\log_e 25} - \frac{8 \cdot 5^{\log_5 2}}{\log_e 5} \\ &= \frac{36}{2 \log_e 5} + \frac{48}{\log_e 5} - 12[\log_5 3] + \frac{4}{2(\log_e 5)} - \frac{16}{(\log_e 5)} \\ &= \frac{16}{\log_e 5} - 12 \log_5 3 = 4 \log_5 e^4 - 4 \log_5 27 = 4 \log_5 \left[ \frac{e^4}{27} \right] \end{aligned}$$

**33.** Both the curves are defined for  $x > 0$ . Both are positive when  $x > 1$  and negative when  $0 < x < 1$ .

We know that,  $\lim_{x \rightarrow 0^+} \log x \rightarrow -\infty$

Hence,  $\lim_{x \rightarrow 0^+} \frac{\log x}{ex} \rightarrow -\infty$ .

Thus, Y-axis is asymptote of second curve.

and  $\lim_{x \rightarrow 0^+} ex \log x \{(\infty)(-\infty) \text{ form}\}$

$$\begin{aligned} &= \lim_{x \rightarrow 0^+} \frac{e \log x}{1/x} \left( -\frac{\infty}{\infty} \text{ form} \right) \\ &= \lim_{x \rightarrow 0^+} \frac{e(1/x)}{(-1/x^2)} = 0 \quad (\text{using L' Hospital's rule}) \end{aligned}$$

Thus, the first curve starts from (0, 0) but does not include (0, 0).

Now, the given curves intersect, where

$$ex \log x = \frac{\log x}{ex}$$

i.e.  $(e^2 x^2 - 1) \log x = 0$

i.e.  $x = 1, \frac{1}{e}$  (since  $x > 0$ )

Hence, using above results figure could be plotted as

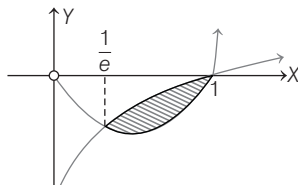

$$\begin{aligned} \therefore \text{The required area} &= \int_{1/e}^1 \left( \frac{\log x}{ex} - ex \log x \right) dx \\ &= \frac{1}{e} \left[ \frac{(\log x)^2}{2} \right]_{1/e}^1 - e \left[ \frac{x^2}{4} (2 \log x - 1) \right]_{1/e}^1 \\ &= \frac{e^2 - 5}{4e} \end{aligned}$$

**34.**  $\therefore y = \left[ \sin^2 \frac{x}{4} + \cos \frac{x}{4} \right]$

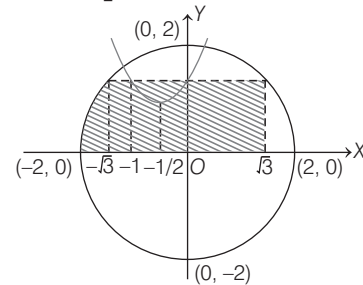

$\therefore 1 < \sin^2 \frac{x}{4} + \cos \frac{x}{4}$

For  $x \in (-2, 2)$

$\therefore y = \left[ \sin^2 \frac{x}{4} + \cos \frac{x}{4} \right] = 1$

Now, we have to find out the area enclosed by the circle  $x^2 + y^2 = 4$ , parabola  $\left( y - \frac{3}{4} \right) = \left( x + \frac{1}{2} \right)^2$ , line  $y = 1$  and X-axis. Required area is shaded area in the figure.

Hence required area,

$$\begin{aligned} &= \sqrt{3} \times 1 + (\sqrt{3} - 1) \times 1 + \int_{-1}^0 (x^2 + x + 1) dx \\ &\quad + 2 \int_{\sqrt{3}}^2 (\sqrt{4 - x^2}) dx \\ &= (2\sqrt{3} - 1) + \left[ \frac{x^3}{3} + \frac{x^2}{2} + x \right]_{-1}^0 \\ &\quad + 2 \left[ \frac{x}{2} \sqrt{4 - x^2} + 2 \sin^{-1} \left( \frac{x}{2} \right) \right]_{\sqrt{3}}^2 \\ &= (2\sqrt{3} - 1) + \left[ 0 - \left( -\frac{1}{3} + \frac{1}{2} - 1 \right) \right] \\ &\quad + 2 \left[ (0 + \pi) - \left( \frac{\sqrt{3}}{2} + \frac{2\pi}{3} \right) \right] \\ &= (2\sqrt{3} - 1) + \frac{5}{6} + \frac{2\pi}{3} - \sqrt{3} \\ &= \left( \frac{2\pi}{3} + \sqrt{3} - \frac{1}{6} \right) \text{ sq units} \end{aligned}$$

**35.** Consider the curve  $|y| + \frac{1}{2} = e^{-|x|} \Rightarrow |y| = e^{-|x|} - \frac{1}{2}$

This curve is symmetrical about both the X and Y-axes.

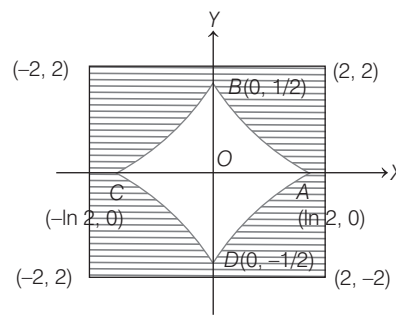

Also, for  $x = 0$  gives  $|y| = \frac{1}{2}$  and  $|y| = 0$  for  $x = \ln 2$

Also,  $x > \ln 2$ .  $|y| < 0$  is not possible.

Also,  $\max\{|x|, |y|\} \leq 2$  is the interior of the square with vertices  $(2, 2)$ ,  $(2, -2)$ ,  $(-2, 2)$  and  $(-2, -2)$ .

The region  $|y| + \frac{1}{2} \geq e^{-|x|}$  and  $\max\{|x|, |y|\} \leq 2$  is given above (as shaded portion).

$\therefore$  The required area =  $4(4 - \text{ar } OABO)$

$$\text{Area } OABO = \int_0^{\log 2} \left( e^{-x} - \frac{1}{2} \right) dx = \frac{1}{2} (1 - \log 2)$$

$$\therefore \text{ Required area} = 4 \left( \frac{7}{2} + \frac{\log 2}{2} \right) = (14 + 2 \log 2) \text{ sq units}$$

**36.**  $y(x + y^3)dx = x(y^3 - x)dy$

$$\Rightarrow xydx + y^4dx = xy^3dy - x^2dy$$

$$\Rightarrow xd(xy) = x^2y^3 \left( \frac{1}{x} dy - \frac{y}{x^2} dx \right)$$

$$\Rightarrow \frac{d(xy)}{(xy)^2} = \frac{y}{x} d\left(\frac{y}{x}\right)$$

$$\Rightarrow -\frac{1}{xy} = \frac{1}{2} \left(\frac{y}{x}\right)^2 + c$$

At  $x = 4, y = -2$

Hence,  $\frac{1}{8} = \frac{1}{2} \left(-\frac{1}{2}\right)^2 + c \Rightarrow c = 0$

Hence,  $y^3 + 2x = 0$

So,  $f(x) = (-2x)^{1/3}$

The second equation given is

$$y = \int_{1/8}^{\sin^2 x} \sin^{-1} \sqrt{t} dt + \int_{1/8}^{\cos^2 x} \cos^{-1} \sqrt{t} dt$$

$$\Rightarrow y' = x \cdot 2 \sin x \cos x + x \cdot 2 \cos x (-\sin x) = 0$$

Hence,  $y$  is constant.

Put  $\sin x = \cos x = \frac{1}{\sqrt{2}}$

Hence,  $y = \int_{1/8}^{1/2} (\sin^{-1} \sqrt{t} + \cos^{-1} \sqrt{t}) dt$   
 $= \int_{1/8}^{1/2} \left(\frac{\pi}{2}\right) dt = \frac{\pi}{2} \cdot \frac{3}{8} = \frac{3\pi}{16}$

So,  $g(x) = \frac{3\pi}{16}$

So, we must find the area between  $y = f(x)$ ,  $y = \frac{3\pi}{16}$

At  $y = \frac{3\pi}{16}; x = -\frac{1}{2} \left(\frac{3\pi}{16}\right)^3 = P$  (say)

Hence, required area =  $\int_P^0 \left(\frac{3\pi}{16} + (2x)^{1/3}\right) dx$   
 $= \left(\frac{3\pi}{16}x + 2^{1/3} \cdot \frac{x^{4/3}}{4/3}\right)_P^0 = \frac{1}{8} \left(\frac{3\pi}{16}\right)^4$

**37.** Area  $S_1 = \frac{1}{4} \int_0^4 y^2 dy = \frac{1}{4} \times \frac{64}{3} = \frac{16}{3}$  sq units

Area  $S_3 = \frac{1}{4} \int_0^4 x^2 \cdot dx = \frac{1}{4} \times \frac{64}{3} = \frac{16}{3}$  sq units

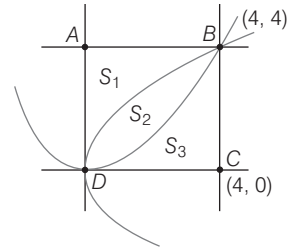

Area of square  $(ABCD) = 4 \times 4 = 16$  sq units

$$\Rightarrow S_2 = 16 - S_1 - S_3 = 16 - \frac{16}{3} - \frac{16}{3} = \frac{16}{3} \text{ sq units}$$

$$\therefore S_1 + S_2 + S_3 = 16$$

**38.** By the given condition,

Area  $OLMP = 2$  area of  $\triangle OQL$

$$= \int_0^{3/2} (1 + 4x - x^2) dx = 2 \left(\frac{1}{2} \cdot \frac{3}{2} \cdot QL\right)$$

$$= \left[ x + 2x^2 - \frac{x^3}{3} \right]_0^{3/2} = 2 \left(\frac{1}{2} \cdot \frac{3}{2} \cdot \frac{3m}{2}\right)$$

$$\Rightarrow \frac{3}{2} + \frac{9}{2} - \frac{27}{24} = 2 \left(\frac{9}{8}m\right)$$

$$\Rightarrow \frac{39}{8} = \frac{9}{4}m \Rightarrow m = \frac{39}{9 \times 2} = \frac{13}{6} \Rightarrow 6m = 13$$

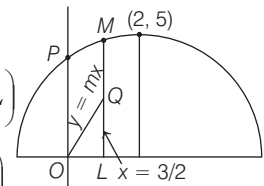

**39.** The area bounded by  $y = f(x)$  and  $y = x$  between the lines  $x = 1$  and  $x = t$  is

$$\int_1^t (f(x) - x) dx$$

But it is equal to  $(t + \sqrt{1 + t^2}) - (1 + \sqrt{2})$

$$\therefore \int_1^t (f(x) - x) dx = (t + \sqrt{1 + t^2}) - (1 + \sqrt{2})$$

On differentiating both sides w.r.t.  $t$ , we get

$$f(t) - t = 1 + \frac{t}{\sqrt{1 + t^2}} \Rightarrow f(t) = 1 + t + \frac{t}{\sqrt{1 + t^2}}$$

$$\Rightarrow f(x) = 1 + x + \frac{x}{\sqrt{1 + x^2}}$$

$$\therefore f(0) = 1$$

**40.**

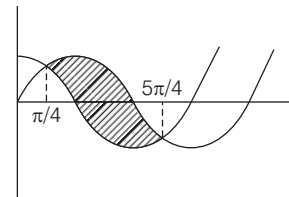

$$A = \int_{\pi/4}^{5\pi/4} (\sin x - \cos x) dx = [-\cos x - \sin x]_{\pi/4}^{5\pi/4}$$

$$= - \left[ \left( \cos \frac{5\pi}{4} + \sin \frac{\pi}{4} \right) - \left( \cos \frac{\pi}{4} + \sin \frac{\pi}{4} \right) \right]$$

$$= - \left[ \left( -\frac{1}{\sqrt{2}} - \frac{1}{\sqrt{2}} \right) - \left( \frac{1}{\sqrt{2}} + \frac{1}{\sqrt{2}} \right) \right]$$

$$= \frac{4}{\sqrt{2}} = 2\sqrt{2}$$

$$\Rightarrow A^4 = (2\sqrt{2})^4 = 64$$