

New

# SURE SHOT QUESTIONS 2026

## Chapter – 14 (Questions)

### Semiconductor Electronics: Materials, Devices and Simple Circuits

#### Questions

1. The V-I characteristic of a silicon diode is as shown in the figure. Calculate the resistance of the diode at (i)  $I = 15 \text{ mA}$  and (ii)  $V = -10 \text{ V}$

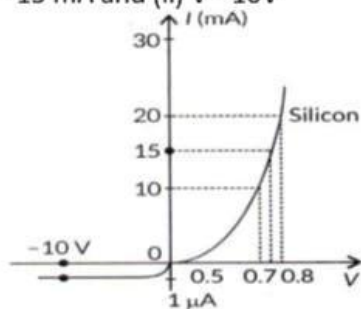

2. Give two difference between a half wave rectifier and a full wave rectifier.
3. Write any two distinguishing features between conductors, semiconductors and insulators on the basis of energy band diagrams.
4. Answer the following, giving reasons :  
(a) The resistance of a p-n junction is low when it is forward biased and is high when it is reversed biased.  
(b) Doping of intrinsic semiconductors is necessary for making electronic devices.
5. Write the two processes that take place in the formation of a p-n junction. Explain with the help of a diagram, the formation of depletion region and barrier potential in a p-n junction.  
OR  
Explain with the help of the diagram the formation of depletion region and barrier potential in a p-n junction  
OR  
Write briefly the important processes that occur during the formation of p-n junction. With the help of necessary diagrams, explain the term barrier potential.
6. Draw V – I characteristics of a p-n junction diode.  
Answer the following giving reasons:
- (a) Why is the reverse bias current almost independent of applied voltage up to breakdown voltage?  
(b) Why does the reverse current show a sudden increase at breakdown voltage?
7. State briefly the processes involved in the formation of p-n junction explaining clearly how the depletion region is formed.  
OR  
Explain with the help of diagram, how a depletion layer and barrier potential are formed in a junction diode.
8. Explain briefly with the help of necessary diagrams, the forward and the reverse biasing of a p-n junction diode. Also draw their characteristic curves in the two cases.  
OR  
Using the necessary circuit diagrams, show how the V-I characteristics of a p-n junction are obtained in  
(i) Forward biasing  
(ii) Reverse biasing.  
OR  
Draw the circuit arrangement for studying the V-I characteristics of a p-n junction diode in (i) forward and (ii) reverse bias. Briefly explain how the typical V-I characteristics of a diode are obtained and draw these characteristics.
9. How does the energy gap of an intrinsic semiconductor effectively change when doped with a (a) trivalent impurity, and (b) pentavalent impurity? Justify your answer in each case.
10. Explain the following, giving reasons :  
(a) A doped semiconductor is electrically neutral.  
(b) In a p-n junction under equilibrium, there is no net current.  
(c) In a diode, the reverse current is practically not dependent on the applied voltage.

11. What is meant by energy band gap in a solid? Draw the energy band diagrams for a conductor, an insulator and a semiconductor.

12. Distinguish between a metal and an insulator on the basis of energy band diagrams.

13. Explain the term 'depletion layer' and 'potential barrier' in a p-n junction diode. How are the (a) width of depletion layer, and (b) value of potential barrier affected when the p-n junction is forward biased?

14. Draw V-I characteristics of a p-n junction diode. Explain, why the current under reverse bias is almost independent of the applied voltage up to the critical voltage.

15. Draw the circuit diagram of a half wave rectifier and explain its working.

16. Explain briefly with the help of necessary diagrams, the forward and the reverse biasing of a p-n junction diode. Also draw their characteristic curves in the two cases.

17. (a) Three photo diodes  $D_1$ ,  $D_2$  and  $D_3$  are made of semiconductors having band gaps of 2.5 eV, 2eV and 3 eV respectively. Which of them will not be able to detect light of wavelength 600 nm?

(b) Why photodiodes are required to operate in reverse bias? Explain.

18. Draw the circuit diagram of a full wave rectifier. Explain its working principle. Show the input waveforms gives to the diodes  $D_1$  and  $D_2$  and the corresponding output waveforms obtained at the load connected to the circuit.

19. Draw V-I characteristics of a p-n junction diode. Answer the following questions, giving reasons:

(i) Why is the current under reverse bias almost independent of the applied potential upto a critical voltage?

(ii) Why does the reverse current show a sudden increase at the critical voltage?

Name any semiconductor device which operates under the reverse bias in the breakdown region.

20. What happens to the width of depletion layer of a p-n junction when it is (i) forward biased, (ii) reverse biased?

21. How is forward biasing different from reverse biasing in a p-n junction diode?

22. Name the junction diode whose I-V characteristics are drawn below:

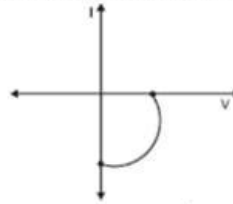

23. Write any two distinguishing features between conductors, semiconductors and insulators on the basis of energy band diagrams.

24. Explain with the help of a circuit diagram, the working of a p-n junction diode as a half-wave rectifier.

25. Assuming that the two diodes  $D_1$  and  $D_2$  used in the electric circuit shown in the figure are ideal, find out the value of the current flowing through  $2.5 \Omega$  resistor.

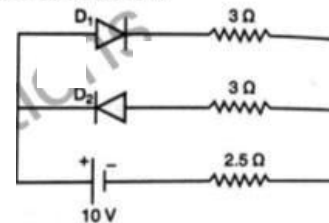

26. Explain the two processes involved in the formation of a p-n junction diode. Hence define the term 'barrier potential'.

27. (i) Explain with the help of a diagram the formation of depletion region and barrier potential in a p-n junction.

(ii) Draw the circuit diagram of a half wave rectifier and explain its working.

28. (a) Distinguish between an intrinsic semiconductor and a p-type semiconductor. Give reasons why a p-type semiconductor is electrically neutral, although  $n_h \gg n_e$

(b) Explain, how the heavy doping of both p-n junction diode results in the electric field of the junction being extremely high even with a reverse bias voltage of a few volts.

29. A semiconductor has equal electron and hole concentration of  $6 \times 10^8 / m^3$ . On doping with certain impurity, electron concentration increases to  $9 \times 10^{12} / m^3$

(i) Identify the new semiconductor obtained after doping.

(ii) Calculate new hole concentration.

30. Answer the following, giving reason :

(a) The resistance of a p-n junction is low when it is forward biased and is high when it is reversed biased.

(b) Doping of intrinsic semiconductors is a necessity for making electronic devices.

31. Explain the term 'depletion layer' and 'potential barrier' in a p-n junction diode. How are the (a) width of depletion layer, and (b) value of potential barrier affected when the p-n junction is forward biased?

32. Assuming that the two diodes  $D_1$  and  $D_2$  used in the electric circuit shown in the figure are ideal, find out the value of the current flowing through  $1\ \Omega$  resistor.

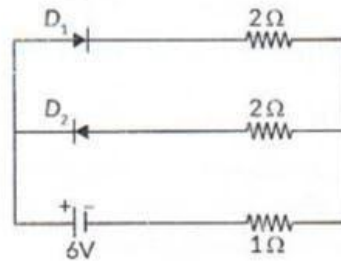



# SURE SHOT QUESTIONS 2026

## Chapter – 14 (Solutions)

### Semiconductor Electronics: Materials, Devices and Simple Circuits

#### Solutions

1. Ans. (i) From the given curve, we have  
Voltage,  $V = 0.8$  volt for current,  $I = 20$  mA  
Voltage,  $V = 0.7$  volt for current,  $I = 15$  mA

$$\Rightarrow \Delta I = (20 - 15) \text{ mA} = 5 \times 10^{-3} \text{ A}$$

$$\Rightarrow \Delta V = (0.8 - 0.7) = 0.1 \text{ V}$$

$$\therefore \text{Resistance, } R = \frac{\Delta V}{\Delta I}$$

$$\Rightarrow R = \frac{0.1}{5 \times 10^{-3}}$$

$$\Rightarrow R = 20 \Omega$$

(ii) For  $V = -10$  V, we have

$$I = -1 \mu\text{A} = -1 \times 10^{-6} \text{ A}$$

$$\Rightarrow R = \frac{10}{1 \times 10^{-6}} = 1.0 \times 10^7 \Omega$$

2. Ans. Differences between half wave rectifier and full wave rectifier are:

	Half wave rectifier		Full wave rectifier
(i)	A half wave rectifier is an electronic circuit which converts only one-half of the AC cycle into pulsating DC. It utilizes only half of AC cycle for the conversion process.	(i)	Full wave rectifier is an electronic circuit which converts entire cycle of AC into pulsating DC.
(ii)	Output frequency of half wave rectifier is equal to the input frequency.	(ii)	Output frequency of full wave rectifier is double the input frequency.

3. Soln. Conductors:

(i) In case of conductors, the valence band is completely filled and the conduction band can have two cases – either it is partially filled with an extremely small energy gap between the valence and conduction bands or it is empty, with the two bands overlapping each other as shown below:



Case 1

Case 2

(ii) Even when a small current is applied, conductors can conduct electricity.

Insulators:

(i) In case of insulators, the energy gap between the conduction and valence bands is very large and the conduction band is practically empty.

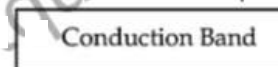

↑  
Forbidden Energy Gap

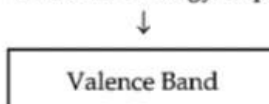

(ii) When an electric field is applied to such kind of material, the electrons find hard to receive such a large amount of energy to reach the conduction band. Thus, the conduction band remains empty. That is why no current flows through insulators.

Semiconductors:

(i) In case of semiconductor, the energy band structure of semiconductors is similar to insulators, But in this case, the size of forbidden energy gap is quite smaller than that of the insulators.

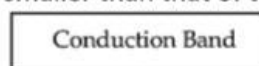

↑  
Forbidden Energy Gap

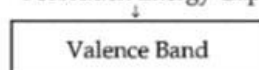

When an electric field is applied to a semiconductor, the electrons in the valence band find it relatively easier to jump to the conduction band. So, the conductivity of

semiconductors lie between the conductivity of conductors and insulators.

4. Ans. (a) In forward biasing, the forward voltage opposes the potential barrier. As a result, potential barrier height is reduced and the width of depletion region decreases. Small increase in forward voltage shows large increase in forward current. Thus resistance in forward bias is reduced. In reverse bias, barrier potential height increases. For large increase in reverse voltage shows small increase in reverse current. Thus, resistance of p-n junction is high to flow of current when reverse biased, (b) Intrinsic semiconductors have very small conductivity at room temperature. When certain impurities in

small amount (= 1 part per million) are added to an intrinsic semiconductor, electrical conductivity of doped semiconductor increases to a great extent and made it useful in many practical applications.

5. Ans. Two processes that take place in the formation of p-n junction are diffusion and drift.

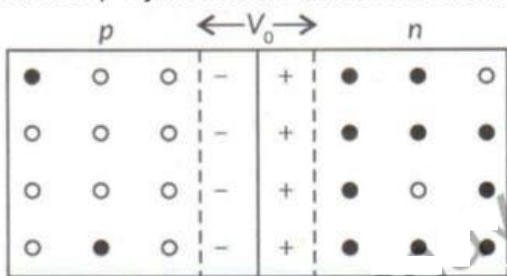

when p-n junction is formed, then at the junction free electrons from n-type diffuse over to p-type, thereby filling in the holes in p-type. Due to this a layer of positive charge is built on n-side and a layer of negative charge is built on p-side of the p-n junction. This layer sufficiently grows up within a very short time of the junction being formed, preventing any further movement of charge carriers (i.e., electrons and holes) across the junction.

Thus a potential difference  $V_0$  of the order of 0.1 to 0.3 V is set up across the p-n junction called potential barrier or junction barrier. The thin region around the junction containing immobile positive and negative charges is known as depletion layer.

6. Ans. I - V characteristics of a p-n junction: The I-V characteristics of a p-n junction do not obey Ohm's law. The I - V characteristics of a p-n junction are as shown in the figure.

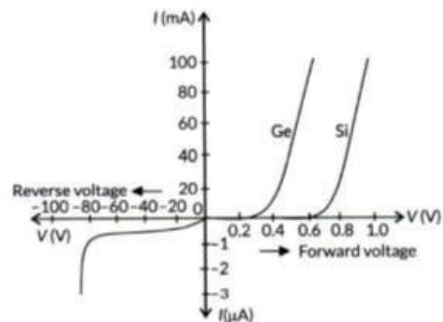

(a) The current of order in reverse bias is due to the drifting of minority charge carriers from one region to another through the junction. A small amount of applied voltage is sufficient to sweep the minority charge carriers through the junction. So, reverse current is almost independent of critical voltage.

(b) During breakdown voltage, enormous covalent bond breaks. As a result large number of charge carriers increases. Therefore current increases at breakdown voltage.

7. Ans. Two processes that take place in the formation of a p-n junction are diffusion and drift.

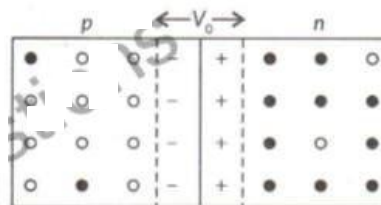

When p-n junction is formed, then at the junction free electrons from n-type diffuse over to p-type, thereby filling in the holes in p-type. Due to this a layer of positive charge is built on n-side and a layer of negative charge is built on p-side of the p-n junction. This layer sufficiently grows up within a very short time of the junction being formed, preventing any further movement of charge carriers (i.e., electrons and holes) across the junction. Thus a potential difference  $V_0$  of the order of 0.1 to 0.3 V is set up across the p-n junction called potential barrier or junction barrier. The thin region around the junction containing immobile positive and negative charges is known as depletion layer.

8. Ans. Forward biased characteristics ; The circuit diagram for studying forward biased characteristics is shown in the figure. Starting from a low value, forward bias voltage is increased step by step (measured by voltmeter) and forward current is noted (by ammeter). A graph is plotted between voltage and current. The curve so obtained is the forward characteristic of the diode.

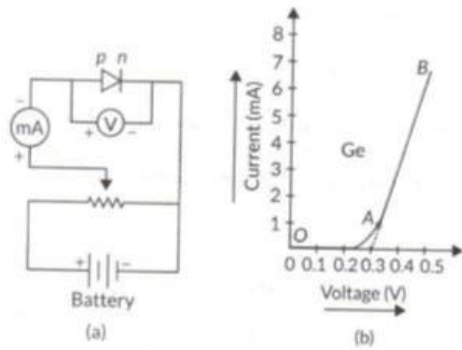

At the start when applied voltage is low, the current through the diode is almost zero. It is because of the potential barrier, which opposes the applied voltage. Till the applied voltage exceeds the potential barrier, the current increases very slowly with increase in applied voltage (OA portion of the graph). With further increase in applied voltage, the current increases very rapidly (AB portion of the graph), in this situation, the diode behaves like a conductor. The forward voltage beyond which the current through the junction starts increasing rapidly with voltage is called threshold or cut-in voltage. If line

AB is extended back, it cuts the voltage axis at potential barrier voltage. Reverse biased characteristics : The circuit diagram for studying reverse biased characteristics is shown in the figure.

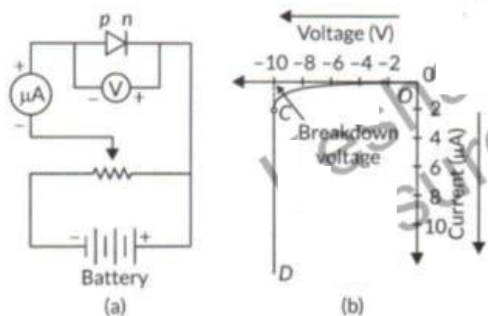

In reverse biased, the applied voltage supports the flow of minority charge carriers across the junction. So, a very small current flows across the junction due to minority charge carriers. Motion of minority charge carriers is also supported by internal potential barrier, so all the minority carriers cross over the junction.

Therefore, the small reverse current remains almost constant over a sufficiently long range of reverse bias, increasing very little with increasing voltage (OC portion of the graph). This reverse current is voltage independent upto certain voltage known as breakdown voltage and this voltage independent current is called reverse saturation current.

9. Ans. (a) The intrinsic semiconductors in which trivalent impurity is added, are called p-type semiconductors. Due to the trivalent impurity, holes are created which can be filled by an electron

of Si - Si covalent bond, i.e., very small energy ranging from 0.01 eV - 0.05 eV is required by an electron of the valence band to move into this hole. Therefore, the acceptor energy level  $E_A$  lies slightly above the top of the valence band. At room temperature, the electrons in the valence band get excited to acceptor energy levels, creating equal number of holes in the valence band.

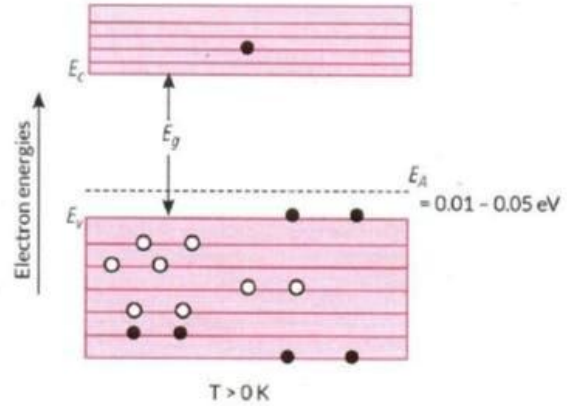

(b) The intrinsic semiconductors in which pentavalent impurity is added are called n-type semiconductor. Due to the pentavalent impurity, a number of loosely bonded electrons are available in the lattice structure and as the voltage applied, then these electrons break the covalent bonds and they are ready to conduct. These electrons occupy the lowest possible energy level in the conduction band. When a certain amount of voltage is applied, these electrons gain energy to cross the forbidden gap and leave the valence band and enter into the conduction band. A very less number of holes are formed in the valence band as the electron leaves valence band to enter conduction band. Moreover, the fermi level is near to the conduction band as more number of electrons enter the conduction band.

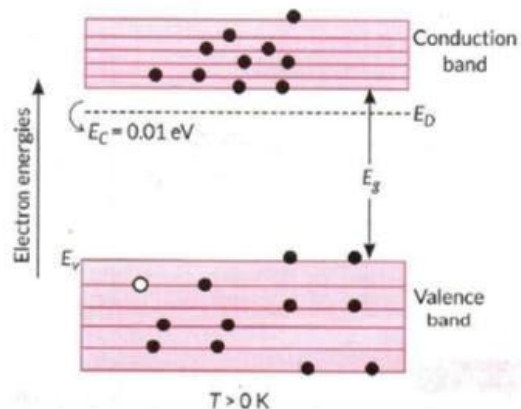

10. Ans. (a) A doped semiconductor is electrically neutral, as it contains equal number of positive and negative charges. By doping of semiconductor, the conductivity of semiconductor increases.

(b) In p-n junction under equilibrium there is no net current because diffusion and drift currents are equal opposite.

(c) For a reverse biased, a very small current flows through p-n junction. The flow of current is due to the movement of minority charge carriers. The reverse current is almost independent of the applied voltage. However, if the reverse bias voltage is continuously increased, for a certain reverse voltage, the current through the p-n junction increases abruptly.

11. Ans. The energy gap between valence band and conduction band is known as energy band gap in a solid.

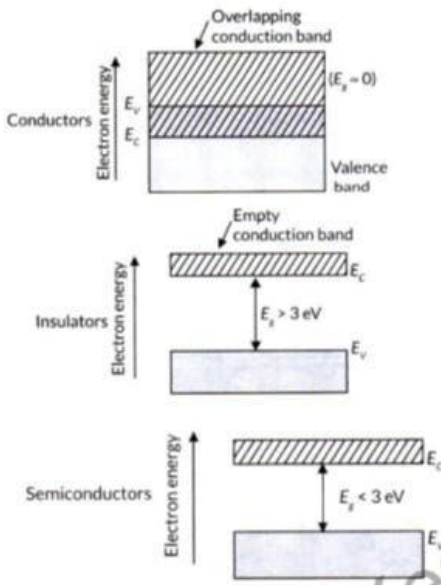

12. Ans. Metals ; For metals, the valence band is completely filled and the conduction band can have two possibilities either it is partially filled with an extremely small energy gap between the valence and conduction bands or it is empty, with the two bands overlapping each other as shown in the figure.

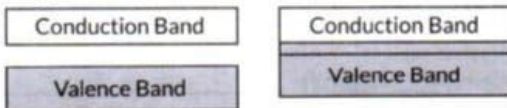

On applying even a small electric field, metals can conduct electricity.

Insulators : For insulators, the energy gap between the conduction and valence bands is very large. Also, the conduction band is completely empty as shown in the figure.

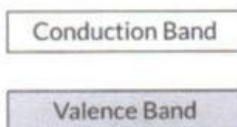

When an electric field is applied across such a solid, the electrons find it difficult to acquire such a large amount of energy to reach the conduction band. Thus, the conduction band continues to be empty. That is why no current flows through insulators.

13. Ans. Depletion layer: The small region in the vicinity of the junction which is depleted of free charge carriers and has only immobile ions is called the depletion layer. Barrier potential : Due to accumulation of negative charges in the p-region and positive charges in the n-region sets up a potential difference across the junction sets up. This acts as a barrier and is called potential barrier  $V_g$  which opposes the further diffusion of electrons and holes across the junction,

(a) In forward biasing the width of depletion layer reduced and the external applied field is able to overcome the Strong electric field of depletion layer. In reverse biasing the width of depletion layer increases and the electric field of depletion layer become more stronger,

(b) As forward voltage opposes the potential barrier and effective barrier potential decreases. It makes the width of the depletion layer smaller.

14. Ans.

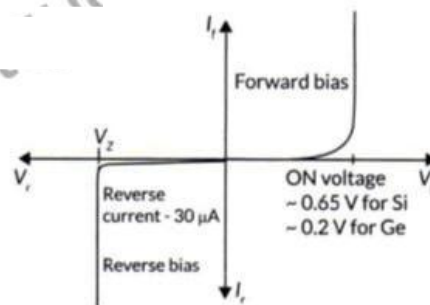

The reverse current is due to minority charge carriers and even a small voltage is sufficient to sweep the minority carriers from one side of the junction to the other side of the junction. Here the current is not limited by the magnitude of the applied voltage but is limited due to the concentration of the minority carrier on either side of the junction.

15. Ans. Half wave rectifier:

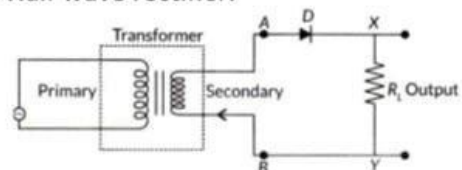

It consists of a diode  $D$  connected in series with load resistor  $R_L$  across the secondary windings of a step-down transformer. Primary of transformer is connected to a.c. supply. During positive half cycle of input a.c., end  $A$  of the secondary winding becomes

positive and end 6 negative. Thus, diode D becomes forward biased and conducts the current through it. So, current in the circuit flows from A to B through load resistor  $R_L$ .

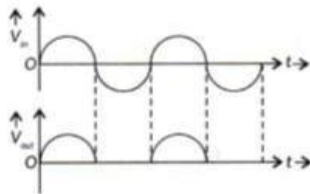

During negative half cycle of input a.c., end A of the secondary winding becomes negative and end B positive. Thus, diode D becomes reverse biased and does not conduct any current. So, no current flows in the circuit. Since electric current through load  $R_L$  flows only during positive half cycle, in one direction only i.e., from A to B, so d.c. is obtained across  $R_L$ .

**16. Soln.** Forward biased characteristics: The circuit diagram for studying forward biased characteristics is shown in the figure. Starting from a low value, forward bias voltage is increased step by step (measured by voltmeter) and forward current is noted (by ammeter). A graph is plotted between voltage and current. The curve so obtained is the forward characteristic of the diode.

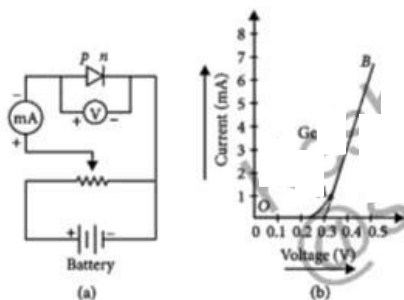

At the start when applied voltage is low, the current through the diode is almost zero. It is because of the potential barrier, which opposes the applied voltage. Till the applied voltage exceeds the potential barrier, the current increases very slowly with increase in applied voltage (OA portion of the graph). With further increase in applied voltage, the current increases very rapidly (AB portion of the graph), in this situation, the diode behaves like a conductor. The forward voltage beyond which the current through the junction starts increasing rapidly with voltage is called threshold or cut-in voltage. If line AB is extended back, it cuts the voltage axis at potential barrier voltage.

Reverse biased characteristics: The circuit diagram for studying reverse biased characteristics is shown in the figure.

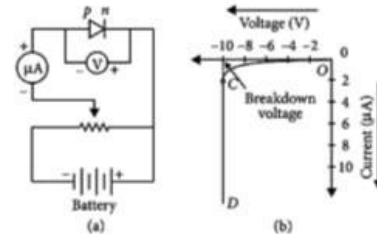

In reverse biased, the applied voltage supports the flow of minority charge carriers across the junction. So, a very small current flows across the junction due to minority charge carriers.

Motion of minority charge carriers is also supported by internal potential barrier, so all the minority carriers cross over the junction.

Therefore, the small reverse current remains almost constant over a sufficiently long range of reverse bias, increasing very little with increasing voltage (OC portion of the graph). This reverse current is voltage independent upto certain voltage known as breakdown voltage and this voltage independent current is called reverse saturation current.

**17. Soln.** (a) Given,  $\lambda = 600 \text{ nm} = 6 \times 10^{-7} \text{ m}$

$$E = \frac{hc}{\lambda} = \frac{6.6 \times 10^{-34} \times 3 \times 10^8}{6 \times 10^{-7} \times 1.6 \times 10^{-19}} \text{ eV} = 2.06 \text{ eV}$$

As, energy gaps of diodes  $D_1$  and  $D_3$  are greater than the given energy of the incident radiation. Hence diodes  $D_1$  and  $D_3$  will not be able to detect light of wavelength 600 nm.

(b) In reverse bias condition of photodiode, the change in saturation reverse current is directly proportional to the change in the incident light flux or light intensity, which can be measured accurately. It is not so when photodiode is forward biased.

**18. Soln.**

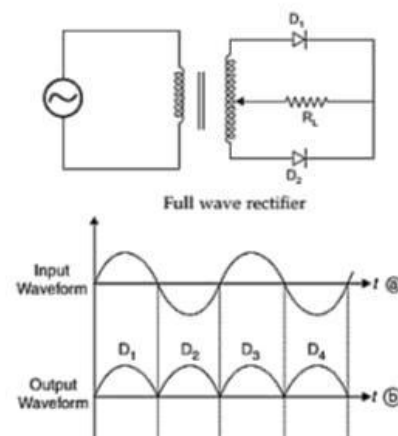

During first half of input sinusoidal ac signal diode  $D_1$  conducts as it is forward bias and during second half of input ac signal diode  $D_2$  conducts as it is forward bias now.  $D_2$  and  $D_1$  are inverse bias conditions during first and second half respectively and doesn't conduct. Due to this output appears as waveform (b).

19. Soln.  $V - I$  characteristics of p-n junction diode:

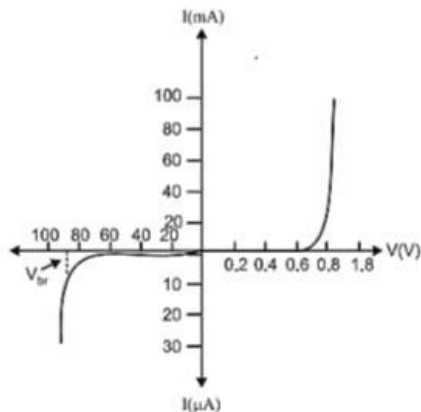

- (i) Under the reverse bias condition, the holes of p-side are attracted towards the negative terminal of the battery and the electrons of the n-side are attracted towards the positive terminal of the battery. This increases the depletion layer and the potential barrier. However the minority charge carriers are drifted across the junction producing a small current. At any temperature the number of minority carriers is constant and very small so there is the small current at any applied potential. This is the reason for the current under reverse bias to be almost independent of applied potential. At the critical voltage, avalanche break down takes place which results in a sudden flow of large current.
- (ii) At the critical voltage, the holes in the n-side and conduction electrons in the p-side are accelerated due to the reverse-bias voltage. These minority carriers acquire sufficient kinetic energy from the electric field and collide with valence electrons. Thus, the bond is finally broken and the valence electrons move into the conduction band resulting in enormous flow of electrons and thus result in formation of hole – electron pairs. Thus, there is a sudden increase in the current at the critical voltage.

Zener diode is a semiconductor device which operates under the reverse bias condition in the breakdown region.

20. Soln. (i) Forward biased: Potential drop across the junction decreases and diffusion of holes and electrons across the junction

increases. It makes the width of the depletion layer smaller.

- (ii) Reverse biased: Potential drop across the junction increases and diffusion of holes and electrons across the junction decreases. It makes the width of the depletion layer larger.

21. Soln. Forward Biasing: The positive terminal of the external battery is connected to p-side and negative terminal of battery to n-side of p-n junction. The forward bias voltage opposes the potential barrier. Due to this, the potential barrier is reduced and hence the depletion becomes thin. The resistance of p-n region junction decreases.

Reverse biasing: The negative terminal of the external battery is connected to p-side and positive terminal of battery to n-side of p-n junction. The reverse bias voltage supports the potential barrier. Due to this, the potential barrier is increased. The resistance of p-n junction becomes high.

22. Soln. This is the characteristic of solar cell.

23. Soln. Conductors:

- (iii) In case of conductors, the valence band is completely filled and the conduction band can have two cases – either it is partially filled with an extremely small energy gap between the valence and conduction bands or it is empty, with the two bands overlapping each other as shown below:

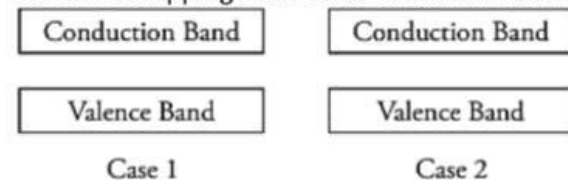

- (iv) Even when a small current is applied, conductors can conduct electricity.

Insulators:

- (iii) In case of insulators, the energy gap between the conduction and valence bands is very large and the conduction band is practically empty.

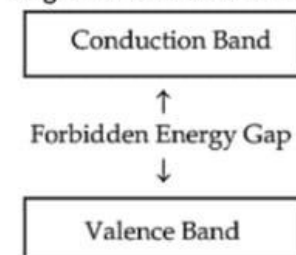

- (iv) When an electric field is applied to such kind of material, the electrons find it hard to receive such a large amount of energy to reach the conduction band. Thus, the conduction band

remains empty. That is why no current flows through insulators.

Semiconductors:

(ii) In case of semiconductor, the energy band structure of semiconductors is similar to insulators, But in this case, the size of forbidden energy gap is quite smaller than that of the insulators.

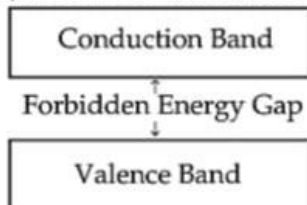

When an electric field is applied to a semiconductor, the electrons in the valence band find it relatively easier to jump to the conduction band. So, the conductivity of semiconductors lies between the conductivity of conductors and insulators.

24. Soln.

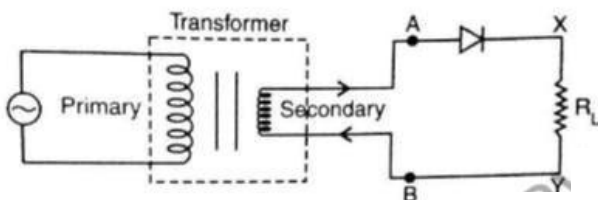

Working: During one half of the input a.c., the diode is forward biased and a current flows through  $R_L$ . During the other half of the input a.c., the diode is reverse biased and no current flows through the load  $R_L$ .

Hence, the given a.c. input is rectified.

25. Soln. In the cycle, if  $D_1$  and  $D_2$  are short then equivalent circuit will result as:

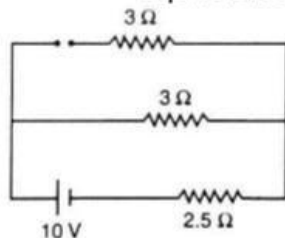

$D_2$  is reverse biased

$\therefore D_1$  conducts

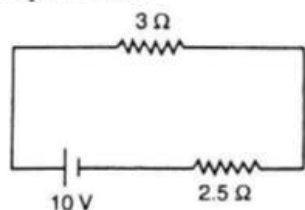

$$\therefore I = \frac{10}{3+2.5} = \frac{10}{5.5} = 1.8 \text{ A}$$

26. Soln. Diffusion: It is the process of movement of majority charge carriers from their majority zone (i.e., electrons from  $n \rightarrow p$  and holes from  $p \rightarrow n$ ) due to the electric field developed at the junction.

Drift: Process of movement of minority charge carriers (i.e., holes from  $n \rightarrow p$  and electrons from  $p \rightarrow n$ ) due to the electric field developed at the junction.

Barrier potential: The loss of electrons from the n-region and gain of electrons by p-region causes a difference of potential across the junction, whose polarity is such as to oppose and then stop the further flow of charge carriers. This (stopping) potential is called Barrier potential.

27. Soln. (i) Due to diffusion and drift, the electrons and holes move across the junction, creating a final stage in which a region is created across the junction wall, which gets devoid of the mobile charge carriers. This region is called depletion region; the potential difference across the region is called Barrier potential.

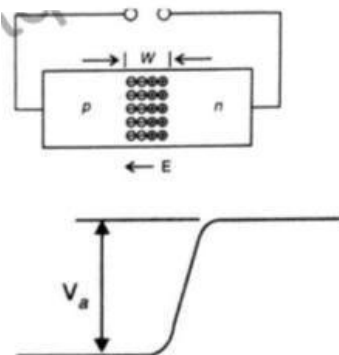

(ii)

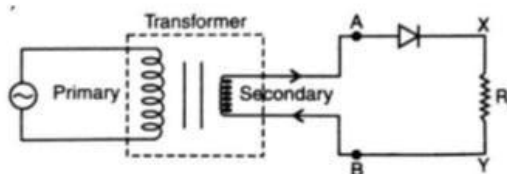

Working: If an alternating voltage is applied across a diode in series with a load, a pulsating voltage will appear across the load only during that half cycle of the ac input during which the diode is forward biased.

Therefore, in the positive half-cycle of ac input there is current through the load resistor  $R_L$  and we get an output voltage whereas there is no output

during the negative half cycle. Thus, the output voltage is restricted to only one direction and is said to be rectified.

28. Soln. (a)

	Intrinsic semiconductor	Extrinsic semiconductor
(i)	It is a semiconductor in pure form.	It is a semiconductor doped with trivalent or pentavalent impurity atoms.
(ii)	Intrinsic charge carriers are electrons and holes with equal concentration.	The two concentrations are unequal in it. There is excess of electrons in n-type and excess of holes in p-type semiconductors.
(iii)	Current due to charge carriers is feeble (of the order of $\mu A$ ).	Current due to charge carriers is significant (of the order of mA).

(b) If p-type and n-type semiconductor are heavily doped. Then due to diffusion of electrons from n-region to p-region, and of holes from p-region to n-region, a depletion region formed of size of order less than  $1\mu m$ . The electric field directing from n-region to p-region produces a reverse bias voltage of about 5V and electric field becomes very large.

$$E = \frac{\Delta V}{\Delta x} = \frac{5V}{1\mu m} \approx 5 \times 10^6 V/m$$

29. Soln. (i) The doped semiconductor is n-type

$$(ii) nenh = ni^2$$

$$nh = ni^2 / ne = \frac{(6 \times 10^8)^2}{9 \times 10^{12}} = 4 \times 10^4 \text{ per } m^3$$

30. Soln.

(a) In forward biasing, the forward voltage opposes the potential barrier. As a result, potential barrier height is reduced and the width of depletion

region decreases. Small increase in forward voltage shows large increase in forward current. Thus resistance in forward bias is reduced. In reverse bias, barrier potential height increases. For large increase in reverse voltage shows small increase in reverse current. Thus, resistance of p-n junction is high to flow of current when reverse biased.

Intrinsic semiconductors have very small conductivity at room temperature. When certain impurities in small amount ( $\approx 1$  part per million) are added to an intrinsic semiconductor, electrical conductivity of doped semiconductor increases to a great extent and made it useful in many practical applications.

31. Soln. Depletion layer: The small region in the vicinity of the junction which is depleted of free charge carriers and has only immobile ions is called the depletion layer.

Barrier potential : Due to accumulation of negative charges in the p-region and positive charges in the n-region sets up a potential difference across the junction sets up. This acts as a barrier and is called potential barrier  $V_b$  which opposes the further diffusion of electrons and holes across the junction.

(a) In forward biasing the width of depletion layer reduced and the external applied field is able to overcome the strong electric field of depletion layer. In reverse biasing the width of depletion layer increases and the electric field of depletion layer become more stronger.

As forward voltage opposes the potential barrier and effective barrier potential decreases. It makes the width of the depletion layer smaller.

32. Soln. According to the question

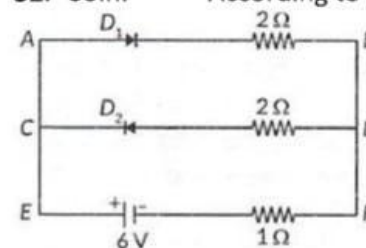

$$R = R_{AB} + R_{EF} = 2 + 1 = 3\Omega$$

$$I = \frac{V}{R} = \frac{6}{3} = 2A$$